

FAX-L1000

SERVICE MANUAL

REVISION 0

FAX-L1000	H12-1613	230V	EC
FAX-L1000	H12-1614	230V	UK
FAX-L1000	H12-1615	230V	GER
FAX-L1000	H12-1617	230V	FRN
FAX-L1000	H12-1618	230V	AUS
FAX-L1000	H12-1619	230V	AE
OPTION MEMORY VII (4MB)	H11-4721		
VERIFICATION STAMP UNIT1	H12-3162		
YELLOW INK TO REFILL	H12-3372		
FOR VERIFICATION STAMP			
PAPER FEED UNIT PF-52	R73-5006		
ENVELOPE FEEDER EF-52	R73-5005		
DUPLEX UNIT DU-52	R73-5004		
FAX-L1000 ISDN KIT	H11-5553		
FAX-L1000 Printer Kit	H11-5513		
RAM DIMM MODULE			
FAX-L1000 PostScript Kit	H11-5533		
FAX-L1000 Network	H11-5543		
Printer Upgrade kit			

Canon

FEB. 2000

HY8-10AN-000

Application

This manual has been issued by Canon Inc. for qualified persons to learn technical theory, installation, maintenance, and repair of products. This manual covers all localities where the products are sold. For this reason, there may be information in this manual that does not apply to your locality.

Corrections

This manual may contain technical inaccuracies or typographical errors due to improvements or changes in products. When changes occur in applicable products or in the content of this manual, Canon will release technical information as the need arises. In the event of major changes in the contents of this manual over a long or short period, Canon will issue a new editions of this manual.

The following paragraph does not apply to any countries where such provisions are inconsistent with local law.

Trademarks

The product names and company names described in this manual are the registered trademarks of the individual companies.

Copyright

This manual is copyrighted with all rights reserved. Under the copyright laws, this manual may not be copied, reproduced or translated into another language, in whole or in part, without the written consent of Canon Inc..

Copyright © 2000 by Canon Inc.

CANON INC.

Office Imaging Products Technical Support Dept. 3

5-1 Hakusan 7-Chome, Toride-city, Ibaraki 302-8501, Japan

DTP System





This manual was produced on an Apple Macintosh®, personal computer, final pages were printed on AGFA SelectSet Avantara 25.

All graphics were produced with Macromedia® FreeHand® 8.0J.

All documents and all page layouts were created with Adobe PageMaker® 6.5J.

I. MEANINGS OF MARKS

The marks used in this manual have the following meanings.

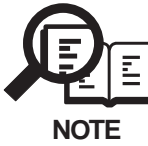
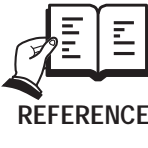
Mark	Meaning
	Indicates a general caution or warning, or otherwise to communicate the presence of a hazard.
	Warns of the possibility of an electric shock.
	Informs you of fire-related cautions.
	Warns against disassembly of parts.
	Informs you that the plug must be removed from the power outlet before starting an operation.
 NOTE	Gives useful information to understand descriptions.
 REFERENCE	Indicates sections to be read to obtain more detailed information.

II. ABOUT THIS MANUAL

This manual consists of the following five chapters, each providing appropriate information needed to service the product.

Chapter 1: Safety and Precautions

Provides cautions and warnings needed when servicing the product while ensuring safety, and explains the protective functions built into the product.

Be sure to go through the descriptions.

Chapter 2: Operating Instructions

Shows how to operate the product correctly, while explaining how to use service data and switches needed for service work.

Chapter 3: Technical Reference

Offers an outline of the product and explains its mechanisms and new features so as to provide a technical understanding of the product.

Chapter 4: Maintenance and Service

Contains information needed to ensure the performance of the product, including adjustments to make during assembly as well as troubleshooting.

Chapter 5: Appendix

Contains information needed for installation, including descriptions related to options.



REFERENCE

-
- For more details of user operations and user reports, see the separate volume of *USER'S GUIDE*.
 - Procedures for assembly/disassembly are not given in this manual. See the illustrations in the separate volume of *PARTS CATALOG*.
 - Detailed description of each SSSW/parameter is not given in this manual except the new SSSWs/parameters added to this fax.
As necessary, see *G3 Facsimile SERVICE DATA HANDBOOK (Rev. 0)*.
 - Detailed description of each error code is not given in this manual except the new error codes added to this fax. As necessary, see *G3 Facsimile Error Code List (Rev. 1)*.
-

III. REVISION HISTORY

REVISION	CONTENT
0	Original

IV. TABLE OF CONTENTS

Chapter 1: Safety and Precautions

Page	
1 - 1	1. DANGER TO PERSONNEL
1 - 1	1.1 Electric Shock
1 - 2	1.1.1 AC line (AC 230V household current)
1 - 2	1.1.2 Telephone line
1 - 2	1.1.3 Printer high voltage terminal
1 - 3	1.2 High Temperature Parts
1 - 4	1.3 Fire
1 - 6	1.4 Moving and Rotating Parts
1 - 8	1.5 Laser Beams
1 - 10	2. DANGER TO EQUIPMENT
1 - 10	2.1 Handling the FAX
1 - 12	2.2 Storage and Handling of FX6 Toner Cartridge
1 - 12	2.2.1 Before unsealing the box
1 - 13	2.2.2 Storing unsealed parts
1 - 13	2.2.3 Storage environment
1 - 13	2.2.4 Effective life
1 - 13	2.2.5 Handling
1 - 15	2.3 Precautions when Servicing
1 - 15	2.3.1 Damage due to electrostatic discharge
1 - 16	2.3.2 Lubrication points
1 - 16	2.3.3 Scanner section
1 - 17	2.3.4 Printer section
1 - 18	2.3.5 Paper load section
1 - 19	2.3.6 Control boards
1 - 20	2.3.7 Replacing ROM
1 - 21	3. PRECAUTIONS FOR DATA PROTECTION
1 - 21	3.1 Battery-backed up Data
1 - 22	3.2 Backed up by Rechargeable Battery
1 - 22	3.2.1 Data backed up by rechargeable battery
1 - 23	3.2.2 Reception image data transfer
1 - 24	3.3 Backed up by Lithium Battery
1 - 24	3.3.1 Data backed up by the lithium battery
1 - 26	3.3.2 Printing the lithium battery backup data list
1 - 28	3.4 Data clear/initialization using Service Operation
1 - 29	3.5 Master Password
1 - 30	3.6 What to do when a Problem Occurs (All clear)
1 - 31	4. PROTECTIVE FUNCTIONS
1 - 31	4.1 Reception Image Data Transfer Function
1 - 31	4.2 Data Battery Backup Function
1 - 32	4.3 Built-in Safety Measures
1 - 32	4.3.1 Overcurrent protection
1 - 32	4.3.2 Lightning protection
1 - 33	4.3.3 Power leakage protection
1 - 34	5. QUALIFICATION REQUIRED FOR INSTALLATION WORK

Chapter 2: Operating Instructions

2 - 1	1. NAMES OF PARTS AND THEIR FUNCTIONS
2 - 1	1.1 Main Unit Overview
2 - 4	1.2 Operation Panel
2 - 7	2. BASIC OPERATION
2 - 7	2.1 Copying
2 - 8	2.2 Telephone (Only possible where a handset or telephone are connected)
2 - 9	2.3 Transmission
2 - 10	2.4 Reception
2 - 11	3. SERVICE OPERATION FUNCTIONS
2 - 11	3.1 Report Output Function
2 - 11	3.1.1 User report output functions
2 - 13	3.1.2 Service report output functions
2 - 26	3.2 User Data Flowchart
2 - 39	3.3 Service Switches
2 - 39	3.3.1 Hardware switches
2 - 41	3.3.2 Service data setting
2 - 42	3.3.3 Service data registration/setting method
2 - 43	3.3.4 Service data flowchart
2 - 49	3.3.5 Explanation of SSSW (Service Soft Switch Settings)
2 - 50	3.3.6 New SSSWs/parameters added to this model
2 - 66	3.4 Test Functions
2 - 66	3.4.1 Test mode overview
2 - 67	3.4.2 Test mode flowchart
2 - 69	3.4.3 D-RAM tests
2 - 70	3.4.4 Print test
2 - 71	3.4.5 Modem and NCU tests
2 - 75	3.4.6 AGING test
2 - 76	3.4.7 Faculty tests
2 - 83	3.4.8 ISDN test

Chapter 3: Technical Reference

3 - 1	1. SPECIFICATIONS
3 - 1	1.1 Overview
3 - 1	1.1.1 Facsimile overview
3 - 2	1.1.2 Option overview
3 - 3	1.2 Configuration and Structure
3 - 3	1.2.1 Product names
3 - 3	1.2.2 External view
3 - 4	1.2.3 Configuration
3 - 5	1.3 Specifications and Functions
3 - 5	1.3.1 Basic specifications
3 - 6	1.3.2 Communications specifications
3 - 8	1.3.3 Scanner section specifications
3 - 11	1.3.4 Printer section specifications
3 - 14	1.3.5 Functions
3 - 18	2. THEORY OF OPERATIONS
3 - 18	2.1 Product Overview
3 - 18	2.1.1 Fax main unit

3 - 18	2.1.2 Option overview
3 - 19	2.1.3 Consumables
3 - 21	2.2 Mechanical Overview
3 - 21	2.2.1 Unit layout diagrams
3 - 21	2.2.2 Document and recording paper flow
3 - 23	2.2.3 Drive system layout
3 - 25	2.2.4 Electrical system layout
3 - 30	2.3 Scanner Section
3 - 30	2.3.1 Document feed section
3 - 35	2.3.2 Optical section
3 - 38	2.4 Paper Load Section
3 - 44	2.5 Printer Section
3 - 45	2.5.1 Paper feed/eject section
3 - 48	2.5.2 LASER/Scanner section
3 - 50	2.5.3 Toner cartridge
3 - 56	2.5.4 Transfer/Separation section
3 - 57	2.5.5 Fixing section
3 - 60	2.6 Circuit Overview
3 - 60	2.6.1 SCNT board function block diagram
3 - 61	2.6.2 Functions
3 - 64	2.6.3 ECNT board function block diagram
3 - 65	2.6.4 Functions
3 - 67	2.6.5 SCNT board component block diagram
3 - 71	2.6.6 ECNT board component block diagram
3 - 73	2.6.7 Flow of image signals
3 - 77	3. NEW FUNCTION
3 - 77	3.1 High-speed Transmission
3 - 77	3.1.1 V.8/V.34 protocol
3 - 91	3.2 JBIG Image Compression Encoding Method
3 - 91	3.2.1 Outline of the JBIG Image Compression Encoding Method
3 - 92	3.2.2 Single Progression Sequential Bi-level Image Compression Method
3 - 93	3.2.3 Encoding Method
3 - 100	3.2.4 Construction of image data with JBIG Image Compression Encoding
3 - 101	3.2.5 Explanation of Bi-level Image Header section (BIH)
3 - 102	3.2.6 Explanation and parameters for each symbol used in BIH
3 - 103	3.2.7 Explanation of Bi-level Image Data (BID) section
3 - 103	3.2.8 Explanation and parameters for each symbol used in BID
3 - 105	3.3 Energy Save Standby (ESS)

Chapter 4: Maintenance and Service

4 - 1	1. MAINTENANCE
4 - 1	1.1 Maintenance Items
4 - 1	1.1.1 Consumables
4 - 3	1.1.2 Cleaning
4 - 5	1.1.3 Periodic inspections
4 - 5	1.1.4 Periodic replacement parts
4 - 6	1.2 Tools
4 - 6	1.2.1 General tools
4 - 6	1.2.2 Special tools

4 - 7	2. CONSUMABLES REPLACEMENT
4 - 7	2.1 Toner Cartridge
4 - 7	2.2 Recording Paper
4 - 8	2.3 Stamp Ink
4 - 11	3. CLEANING
4 - 11	3.1 Main Unit
4 - 11	3.2 Document Pick-up Roller
4 - 11	3.3 Separation Roller (Upper)
4 - 11	3.4 Separation Roller (Lower)
4 - 11	3.5 Scanning Glass (Contact Sensor)
4 - 11	3.6 White Sheet
4 - 11	3.7 Document Feed Roller 1
4 - 11	3.8 Document Feed Roller 2
4 - 11	3.9 Document Eject Roller
4 - 13	3.10 Transfer Guide
4 - 16	3.11 Transfer Charging Roller
4 - 18	3.12 Cassette Pick-Up Roller/Feed Roller/Separation Roller
4 - 20	3.13 Multi-Purpose Tray Pick-Up Roller/Separation Pad
4 - 22	3.14 Feed Roller
4 - 27	3.15 Pre-Transfer Roller and Registration Arm
4 - 29	3.16 Paper Feed Belt and Paper Feed Guide
4 - 31	3.17 Fixing Unit Entrance Guide
4 - 32	3.18 Fixing Film
4 - 35	3.19 Face-Up Deflector, Fixing Delivery Roller and Lower Paper Delivery Guide
4 - 35	4. ADJUSTMENT
4 - 35	4.1 Parts Replacement
4 - 35	4.2 Points to Grease
4 - 35	4.3 Adjustment items
4 - 36	4.4 Leading Edge Margin Adjustment
4 - 38	5. TROUBLESHOOTING
4 - 38	5.1 Troubleshooting
4 - 38	5.1.1 Repairs
4 - 38	5.1.2 Precautions for troubleshooting
4 - 39	5.2 Error Shown on the Display
4 - 39	5.2.1 User error message
4 - 45	5.2.2 Error codes
4 - 64	5.3 Errors not Shown on the Display
4 - 80	6. WIRING DIAGRAM
4 - 80	6.1 Wiring Diagram
4 - 83	6.2 Signal Description

Chapter 5: Appendix

5 - 1	1. INSTALLATION
5 - 2	1.1 Setting up the Fax
5 - 6	1.2 Unpacking
5 - 10	1.3 Removing the Shipping Material
5 - 14	1.4 Assembling the Fax
5 - 41	1.5 Checking Operations
5 - 42	1.6 Moving the Fax Unit

5 - 43	2. SERVICE TOOLS
5 - 43	2.1 Printer Driver Tester
5 - 43	2.1.1 Outline
5 - 44	2.1.2 Explanation of LEDs and Switches
5 - 45	2.1.3. Operation
5 - 51	3. OPTION
5 - 51	3.1 Option Memory VII (4M-BYTE)
5 - 51	3.1.1 Safety and precautions
5 - 51	3.1.2 Service operations
5 - 57	3.1.3 Technical information
5 - 58	3.1.4 Maintenance and service
5 - 61	3.2 Verification Stamp Unit
5 - 61	3.2.1 Service operations
5 - 65	3.2.2 Maintenance and service
5 - 66	3.3 Paper Feed Unit PF-52
5 - 66	3.3.1 Safety and precautions
5 - 67	3.3.2 Service operations
5 - 70	3.3.3 Technical information
5 - 72	3.3.4 Operations
5 - 75	3.3.5 Maintenance and service
5 - 77	3.3.6 Recording Paper Size Priority
5 - 81	3.4 Envelope Feeder EF-52
5 - 81	3.4.1 Service operations
5 - 82	3.4.2 Technical information
5 - 83	3.4.3 Operation
5 - 85	3.4.4 Maintenance and service
5 - 88	3.4.5 Installation Position Adjustment of Separation Guide of Envelope Feeder (adjustment of gap between separation guide and lower separation roller)
5 - 89	3.4.6 Installation Position Adjustment of Envelope Multiple Feed Sensor
5 - 91	3.5 Duplex Unit DU-52
5 - 91	3.5.1 Service operations
5 - 92	3.5.2 Technical information
5 - 93	3.5.3 Operation
5 - 98	3.5.4 Maintenance and service
5 - 103	3.6 FAX-L1000 ISDN Kit
5 - 103	3.6.1 Safety and precautions
5 - 103	3.6.2 Service operations
5 - 112	3.6.3 Technical information
5 - 157	3.6.4 G4 board components
5 - 159	3.6.5 Flow of Image Signals
5 - 163	3.6.6 ISDN Protocol Messages
5 - 171	3.6.7 Maintenance and service
5 - 202	3.7 FAX-L1000 Network Printer Upgrade kit
5 - 202	3.7.1 Safety and precautions
5 - 202	3.7.2 Service operations
5 - 203	3.7.3 Technical information
5 - 205	3.7.4 Maintenance and Service
5 - 209	3.8 FAX-L1000 PostScript kit
5 - 209	3.8.1 Safety and precautions

5 - 209	3.8.2 Service operations
5 - 214	3.8.3 Technical Information
5 - 214	3.8.4 Maintenance and service
5 - 215	3.9 RAM DIMM Module
5 - 215	3.9.1 Safety and precautions
5 - 215	3.9.2 Service operations
5 - 217	3.9.3 Technical informations
5 - 218	3.9.4 Maintenance and service
5 - 219	3.10 FAX-L1000 Printer kit
5 - 219	3.10.1 Safety and precautions
5 - 219	3.10.2 Service operations
5 - 223	3.10.3 Technical informations
5 - 235	3.10.4 Maintenance and service

V. ILLUSTRATION INDEX

Chapter 1: Safety and Precautions

Page	
1 - 2	Figure 1 - 1 Printer High Voltage Terminal
1 - 3	Figure 1 - 2 High Temperature Parts
1 - 7	Figure 1 - 3 Moving and Rotating Parts
1 - 8	Figure 1 - 4 LASER beam warning label
1 - 9	Figure 1 - 5 Laser Shutter
1 - 10	Figure 1 - 6 Precautions 1
1 - 11	Figure 1 - 7 Precautions 2
1 - 13	Figure 1 - 8 Proper Way to Shake Cartridge
1 - 14	Figure 1 - 9 Cautions for Handling
1 - 17	Figure 1 - 10 Printer Section
1 - 18	Figure 1 - 11 Pickup Roller Initial Position
1 - 21	Figure 1 - 12 Lithium / Rechargeable Battery and Jumper Plugs
1 - 23	Figure 1 - 13 Reception Image Data Transfer Method
1 - 30	Figure 1 - 14 All Clear
1 - 12	Table 1 - 1 Environmental conditions

Chapter 2: Operating Instructions

2 - 1	Figure 2 - 1 Front View
2 - 2	Figure 2 - 2 Rear View
2 - 4	Figure 2 - 3 Operation Panel 1
2 - 5	Figure 2 - 4 Operation Panel 2
2 - 6	Figure 2 - 5 Operation Panel 3
2 - 7	Figure 2 - 6 Display for document set
2 - 8	Figure 2 - 7 Document Guides Adjustment
2 - 8	Figure 2 - 8 Document Load Limit
2 - 12	Figure 2 - 9 Memory Clear List
2 - 14	Figure 2 - 10 System Data List (1/7)
2 - 15	Figure 2 - 11 System Data List (2/7)
2 - 16	Figure 2 - 12 System Data List (3/7)
2 - 17	Figure 2 - 13 System Data List (4/7)
2 - 18	Figure 2 - 14 System Data List (5/7)
2 - 19	Figure 2 - 15 System Data List (6/7)
2 - 20	Figure 2 - 16 System Data List (7/7)
2 - 21	Figure 2 - 17 System Dump List (1/2)
2 - 23	Figure 2 - 18 System Dump List (2/2)
2 - 24	Figure 2 - 19 Service Error Activity Report
2 - 26	Figure 2 - 20 User Menu Settings (1/13)
2 - 27	Figure 2 - 21 User Menu Settings (2/13)
2 - 28	Figure 2 - 22 User Menu Settings (3/13)
2 - 29	Figure 2 - 23 User Menu Settings (4/13)
2 - 30	Figure 2 - 24 User Menu Settings (5/13)
2 - 31	Figure 2 - 25 User Menu Settings (6/13)
2 - 32	Figure 2 - 26 User Menu Settings (7/13)
2 - 33	Figure 2 - 27 User Menu Settings (8/13)
2 - 34	Figure 2 - 28 User Menu Settings (9/13)

2 - 35	Figure	2 - 29	User Menu Settings (10/13)
2 - 36	Figure	2 - 30	User Menu Settings (11/13)
2 - 37	Figure	2 - 31	User Menu Settings (12/13)
2 - 38	Figure	2 - 32	User Menu Settings (13/13)
2 - 40	Figure	2 - 33	Slide Switch Location on NCU Board
2 - 40	Figure	2 - 34	Slide Switch Setting
2 - 42	Figure	2 - 35	Service Data Setting Method
2 - 43	Figure	2 - 36	Service Data (1/6)
2 - 44	Figure	2 - 37	Service Data (2/6)
2 - 45	Figure	2 - 38	Service Data (3/6)
2 - 46	Figure	2 - 39	Service Data (4/6)
2 - 47	Figure	2 - 40	Service Data (5/6)
2 - 48	Figure	2 - 41	Service Data (6/6)
2 - 49	Figure	2 - 42	Bit Switch Display
2 - 49	Figure	2 - 43	How to Read Bit Switch Tables
2 - 67	Figure	2 - 44	Test Mode (1/2)
2 - 68	Figure	2 - 45	Test Mode (2/2)
2 - 69	Figure	2 - 46	D-RAM Test
2 - 70	Figure	2 - 47	Print Pattern Check
2 - 73	Figure	2 - 48	Tonal and DTMF Signal Reception Tests
2 - 77	Figure	2 - 49	Sensor Tests
2 - 78	Figure	2 - 50	Toner Sensor
2 - 79	Figure	2 - 51	Stamp Test
2 - 82	Figure	2 - 52	Operation Panel

Chapter 3: Technical Reference

3 - 3	Figure	3 - 1	External View
3 - 10	Figure	3 - 2	Scanning Range
3 - 13	Figure	3 - 3	Printing Range
3 - 20	Figure	3 - 4	Product Overview
3 - 22	Figure	3 - 5	Paper Path
3 - 24	Figure	3 - 6	Drive System Layout
3 - 26	Figure	3 - 7	Electrical System Layout
3 - 29	Figure	3 - 8	Arrangement of Sensors
3 - 31	Figure	3 - 9	Document Feed Section
3 - 33	Figure	3 - 10	Stopper Movement
3 - 37	Figure	3 - 11	Contact Sensor
3 - 40	Figure	3 - 12	Cassette Paper Loading
3 - 43	Figure	3 - 13	Paper Size Detection Configuration (Paper feeder)
3 - 43	Figure	3 - 14	Paper Size Detection Configuration (Option paper feed unit PF-52)
3 - 44	Figure	3 - 15	Printer Section
3 - 46	Figure	3 - 16	Paper Feed/Eject Section
3 - 48	Figure	3 - 17	LASER/Scanner Section
3 - 50	Figure	3 - 18	Toner Cartridge
3 - 51	Figure	3 - 19	Surface Potential
3 - 51	Figure	3 - 20	Primary Charging
3 - 52	Figure	3 - 21	Laser Beam Exposure
3 - 52	Figure	3 - 22	Developing
3 - 53	Figure	3 - 23	Developing Cylinder/Drum Surface Potential

3 - 54	Figure	3 - 24	Drum Cleaning
3 - 55	Figure	3 - 25	High Voltage Terminals
3 - 56	Figure	3 - 26	Transfer
3 - 56	Figure	3 - 27	Separation
3 - 57	Figure	3 - 28	Fixing section
3 - 60	Figure	3 - 29	Function Block Diagram (1)
3 - 64	Figure	3 - 30	Function Block Diagram (2)
3 - 67	Figure	3 - 31	Component Block Diagram (1)
3 - 71	Figure	3 - 32	Component Block Diagram (2)
3 - 74	Figure	3 - 33	Transmission
3 - 76	Figure	3 - 34	Reception
3 - 79	Figure	3 - 35	Typical Protocol
3 - 86	Figure	3 - 36	Late Start
3 - 87	Figure	3 - 37	Between-page Sequence
3 - 88	Figure	3 - 38	Mode Change
3 - 89	Figure	3 - 39	Image Transmission Speed Change from the Receiver
3 - 90	Figure	3 - 40	Image Transmission Speed Change from the Transmitter
3 - 91	Figure	3 - 41	Images
3 - 93	Figure	3 - 42	Encoder and Flow of JBIG Encoding
3 - 94	Figure	3 - 43	Model Templates
3 - 95	Figure	3 - 44	Positions of Pixels in Model Template
3 - 96	Figure	3 - 45	Study Table Study Example 1
3 - 96	Figure	3 - 46	Study Table Study Example 2
3 - 98	Figure	3 - 47	Arithmetic Encoding Conceptual Diagram
3 - 99	Figure	3 - 48	When Predictions are Continually Accurate
3 - 100	Figure	3 - 49	Construction of JBIG Image Data
3 - 100	Figure	3 - 50	BIE Construction Diagram
3 - 101	Figure	3 - 51	BIH Construction Diagram
3 - 103	Figure	3 - 52	BID Construction Diagram
3 - 105	Figure	3 - 53	System Block Diagram
3 - 95	Table	3 - 1	Study Table (Initial values)
3 - 95	Table	3 - 2	Probability Estimation Table

Chapter 4: Maintenance and Service

4 - 8	Figure	4 - 1	Refilling the Stamp Ink 1
4 - 9	Figure	4 - 2	Refilling the Stamp Ink 2
4 - 9	Figure	4 - 3	Refilling the Stamp Ink 3
4 - 12	Figure	4 - 4	Cleaning Location 1
4 - 12	Figure	4 - 5	Cleaning Location 2
4 - 13	Figure	4 - 6	Preparation for Cleaning 1
4 - 13	Figure	4 - 7	Preparation for Cleaning 2
4 - 14	Figure	4 - 8	Cleaning Location 1
4 - 14	Figure	4 - 9	Cleaning Location 2
4 - 15	Figure	4 - 10	Cleaning Location 3
4 - 16	Figure	4 - 11	Preparation for Cleaning
4 - 17	Figure	4 - 12	Cleaning Location
4 - 18	Figure	4 - 13	Preparation for Cleaning 1
4 - 18	Figure	4 - 14	Preparation for Cleaning 2
4 - 19	Figure	4 - 15	Cleaning Location 1

4 - 19	Figure	4 - 16	Cleaning Location 2
4 - 20	Figure	4 - 17	Preparation for Cleaning 1
4 - 20	Figure	4 - 18	Preparation for Cleaning 2
4 - 21	Figure	4 - 19	Cleaning Location 1
4 - 21	Figure	4 - 20	Cleaning Location 2
4 - 22	Figure	4 - 21	Preparation for Cleaning 1
4 - 22	Figure	4 - 22	Preparation for Cleaning 2
4 - 23	Figure	4 - 23	Preparation for Cleaning 3
4 - 23	Figure	4 - 24	Preparation for Cleaning 4
4 - 24	Figure	4 - 25	Preparation for Cleaning 5
4 - 24	Figure	4 - 26	Preparation for Cleaning 6
4 - 25	Figure	4 - 27	Preparation for Cleaning 7
4 - 25	Figure	4 - 28	Preparation for Cleaning 8
4 - 26	Figure	4 - 29	Cleaning Location
4 - 27	Figure	4 - 30	Preparation for Cleaning 1
4 - 27	Figure	4 - 31	Preparation for Cleaning 2
4 - 28	Figure	4 - 32	Cleaning Location
4 - 29	Figure	4 - 33	Preparation for Cleaning
4 - 29	Figure	4 - 34	Cleaning Location 1
4 - 30	Figure	4 - 35	Cleaning Location 2
4 - 31	Figure	4 - 36	Preparation for Cleaning
4 - 31	Figure	4 - 37	Cleaning Location
4 - 32	Figure	4 - 38	Preparation for Cleaning 1
4 - 32	Figure	4 - 39	Preparation for Cleaning 2
4 - 33	Figure	4 - 40	Preparation for Cleaning 3
4 - 33	Figure	4 - 41	Cleaning Location
4 - 34	Figure	4 - 42	Preparation for Cleaning
4 - 34	Figure	4 - 43	Cleaning Location
4 - 37	Figure	4 - 44	Leading Edge Margin Adjustment
4 - 45	Figure	4 - 45	Service Error Code Display
4 - 67	Figure	4 - 46	Faulty Print Samples
4 - 73	Figure	4 - 47	Fixing Nip Width
4 - 80	Figure	4 - 48	Wiring Diagram (1)
4 - 81	Figure	4 - 49	Wiring Diagram (2)
4 - 82	Figure	4 - 50	Wiring Diagram (3)

Chapter 5: Appendix

5 - 40	Figure	5 - 1	All Clear
5 - 41	Figure	5 - 2	Copy Operation
5 - 43	Figure	5 - 3	Printer Driver Tester
5 - 44	Figure	5 - 4	LEDs and Switches
5 - 45	Figure	5 - 5	Connect Printer Driver Tester
5 - 51	Figure	5 - 6	External View
5 - 52	Figure	5 - 7	Preparations for Installation 1
5 - 52	Figure	5 - 8	Preparations for Installation 2
5 - 53	Figure	5 - 9	DRAM Boards Installation (1)
5 - 54	Figure	5 - 10	DRAM Boards Installation (2)
5 - 55	Figure	5 - 11	Flowchart of D-RAM test 1
5 - 55	Figure	5 - 12	D-RAM Board Installation Check
5 - 57	Figure	5 - 13	DRAM Board (4MB)

5 - 61	Figure	5 - 14	External View
5 - 61	Figure	5 - 15	Attachment to the Main Unit 1
5 - 62	Figure	5 - 16	Attachment to the Main Unit 2
5 - 62	Figure	5 - 17	Attachment to the Main Unit 3
5 - 63	Figure	5 - 18	Attachment to the Main Unit 4
5 - 63	Figure	5 - 19	Attachment to the Main Unit 5
5 - 64	Figure	5 - 20	Flowchart of Changing SSSW
5 - 66	Figure	5 - 21	Moving and Rotating Parts
5 - 67	Figure	5 - 22	External View
5 - 69	Figure	5 - 23	Pickup Roller Initial Position
5 - 70	Figure	5 - 24	External View
5 - 72	Figure	5 - 25	Cross-Sectional Diagram
5 - 73	Figure	5 - 26	Arrangement of Switches
5 - 74	Figure	5 - 27	Electrical Circuit Section
5 - 78	Figure	5 - 28	Reading the Recording Paper Size Table
5 - 81	Figure	5 - 29	External View
5 - 82	Figure	5 - 30	External View
5 - 83	Figure	5 - 31	Envelope Feeder
5 - 83	Figure	5 - 32	Cross-Sectional Diagram
5 - 84	Figure	5 - 33	Arrangement of Sensors
5 - 84	Figure	5 - 34	Electrical Circuit Section
5 - 88	Figure	5 - 35	Adjustment of Separation Guide
5 - 90	Figure	5 - 36	Adjustment of Envelope Multiple Feed Sensor
5 - 91	Figure	5 - 37	External View
5 - 92	Figure	5 - 38	External View
5 - 95	Figure	5 - 39	Duplexing Unit
5 - 95	Figure	5 - 40	Cross-Sectional Diagram
5 - 96	Figure	5 - 41	Arrangement of Sensors
5 - 97	Figure	5 - 42	Electrical Circuit Section
5 - 103	Figure	5 - 43	External View
5 - 104	Figure	5 - 44	Preparations for Installation 1
5 - 105	Figure	5 - 45	Preparation for Installation 2
5 - 105	Figure	5 - 46	Preparation for Installation 3A
5 - 106	Figure	5 - 47	Preparation for Installation 3B
5 - 106	Figure	5 - 48	Preparation for Installation 4
5 - 107	Figure	5 - 49	FAX-L1000 ISDN Kit Installation
5 - 108	Figure	5 - 50	FAX-L1000 Printer Kit (Option) Installation
5 - 109	Figure	5 - 51	ROM Replacement 1
5 - 109	Figure	5 - 52	ROM Replacement 2
5 - 110	Figure	5 - 53	All Clear Operation
5 - 111	Figure	5 - 54	ROM Version Check
5 - 112	Figure	5 - 55	External View
5 - 124	Figure	5 - 56	G4 → G3 Fallback Procedure (1)
5 - 125	Figure	5 - 57	G4 → G3 Fallback Procedure (2)
5 - 138	Figure	5 - 58	System Data List (1/10)
5 - 139	Figure	5 - 59	System Data List (2/10)
5 - 140	Figure	5 - 60	System Data List (3/10)
5 - 141	Figure	5 - 61	System Data List (4/10)
5 - 142	Figure	5 - 62	System Data List (5/10)
5 - 143	Figure	5 - 63	System Data List (6/10)

5 - 144	Figure	5 - 64 System Data List (7/10)
5 - 145	Figure	5 - 65 System Data List (8/10)
5 - 146	Figure	5 - 66 System Data List (9/10)
5 - 147	Figure	5 - 67 System Data List (10/10)
5 - 148	Figure	5 - 68 System Dump List (1/3)
5 - 149	Figure	5 - 69 System Dump List (2/3)
5 - 150	Figure	5 - 70 System Dump List (3/3)
5 - 151	Figure	5 - 71 Dch Log Report
5 - 155	Figure	5 - 72 Bch Log Report
5 - 157	Figure	5 - 73 Component block diagram
5 - 159	Figure	5 - 74 Transmission Image Signal Flow
5 - 161	Figure	5 - 75 Reception Image Signal Flow
5 - 167	Figure	5 - 76 D-Channel Protocol Flow
5 - 169	Figure	5 - 77 B-Channel Protocol Flow (G4)
5 - 170	Figure	5 - 78 B-Channel Protocol Flow (G3)
5 - 202	Figure	5 - 79 External View
5 - 204	Figure	5 - 80 Status LEDs
5 - 206	Figure	5 - 81 Connector Locations
5 - 209	Figure	5 - 82 External View
5 - 215	Figure	5 - 83 External View
5 - 219	Figure	5 - 84 External View
5 - 220	Figure	5 - 85 Preparations for Installation 1
5 - 220	Figure	5 - 86 Preparations for Installation 2
5 - 221	Figure	5 - 87 FAX-L1000 Printer Kit Installation
5 - 223	Figure	5 - 88 External View
5 - 228	Figure	5 - 89 Options
5 - 229	Figure	5 - 90 Flow of Print Data 1
5 - 230	Figure	5 - 91 Flow of Print Data 2
5 - 231	Figure	5 - 92 PDL Menu Flow
5 - 233	Figure	5 - 93 Components
5 - 234	Figure	5 - 94 Block Diagram
5 - 236	Figure	5 - 95 Test Print
5 - 237	Figure	5 - 96 Cleaning Page
5 - 47	Table	5 - 1 Printer Operation Setting
5 - 48	Table	5 - 2 Printer Condition (1)
5 - 49	Table	5 - 3 Printer Condition (2)

This page intentionally left blank

Chapter 1

Safety and Precautions

1. DANGER TO PERSONNEL

1.1 Electric Shock



Precautions

Before disassembling the fax, carry out the following to prevent electric shock:

- (1) Disconnect the power cord from the outlet.
- (2) Disconnect the modular jack cord (telephone line) from the fax.

Precautions when servicing the fax with the power on

When you must service the fax with the power cord plugged in, you must not ground your body with grounding wrist straps.

This is to prevent electricity passing to your body.

1.1.1 AC line (AC 230V household current)

Power supply unit (primary side)

The AC 230V is supplied to the primary side of the power supply unit when the power cord is plugged in.

1.1.2 Telephone line

NCU board (primary side)

When connected to the telephone line, a line voltage of approx. DC 48V is supplied to the fax from the telephone line.

And when the ringing signal is received, approx. AC 90Vrms is supplied.

1.1.3 Printer high voltage terminal

When the printer cover sensor is pressed with the printer cover closed, voltage of approx. AC 1600V p-p maximum is supplied to the printer high voltage terminal. When you press the printer cover sensor, be careful not to touch the high voltage terminal.

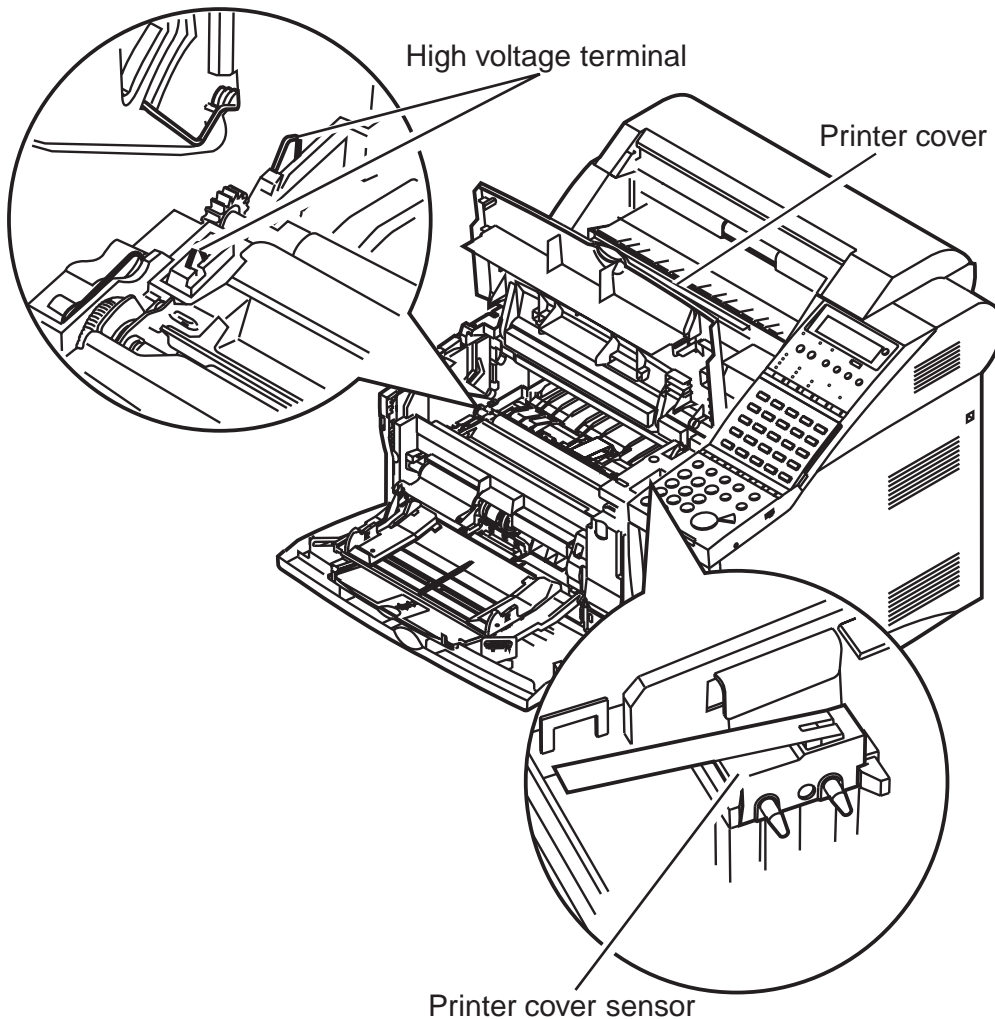

Figure 1-1 Printer High Voltage Terminal

1.2 High Temperature Parts



Precautions

To prevent burns while disassembling the fax, disconnect the power cord at least 10 minutes before starting disassembly, to allow high temperature parts to cool down.

How to treat burns

Heat of about 122°F (50°C) or more causes burns. Also, the longer the contact, the more severe the burn.

When treating a burn, the first minute after receiving the burn is the most important. Cool the burn immediately with cold running water. In the case of a serious burn, seek medical attention immediately.

The temperatures of the parts shown below become more than 50°C during operation. Be Careful not to burn yourself on any of these parts during servicing.

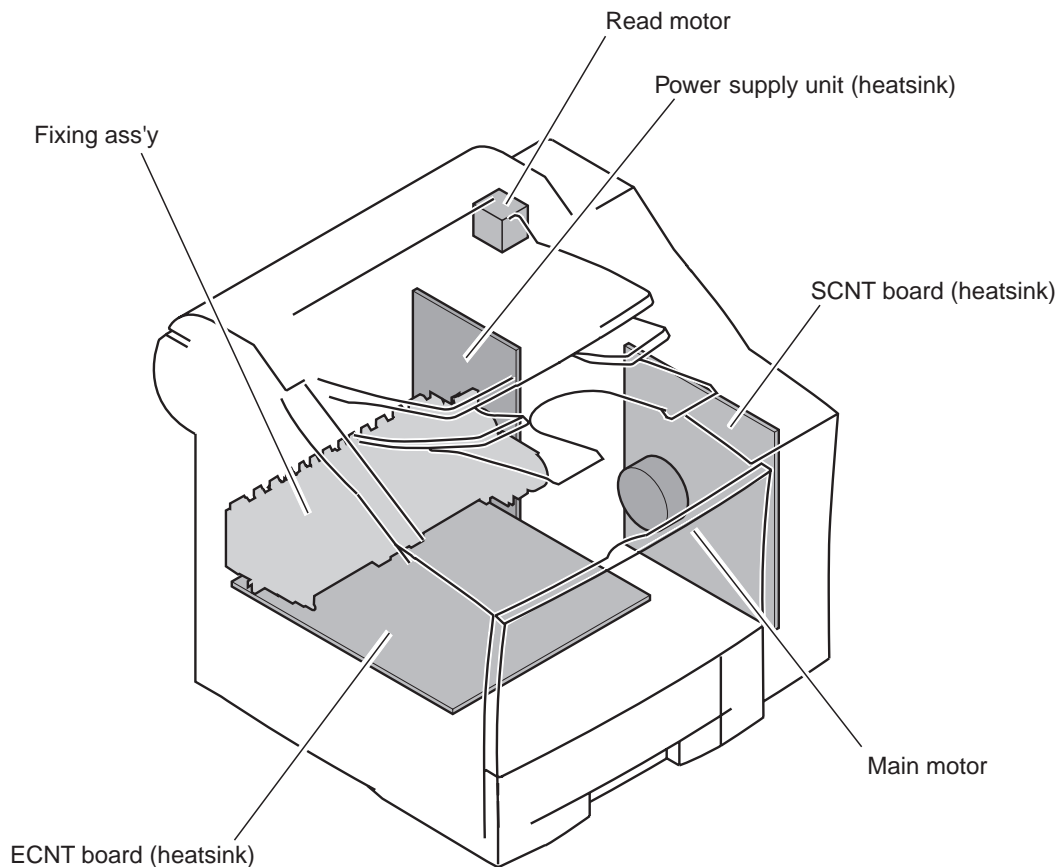

Figure 1-2 High Temperature Parts

1.3 Fire



Danger

Do not throw the lithium battery or the toner cartridge into fire.

Lithium battery

The lithium battery contain lithium, organic solvents and other combustible substances. If the lithium battery is thrown into fires, it may rupture and burn fiercely.

Toner

The toner in the toner cartridge contains flammable substances.

The danger of fire exists with toner scattered around in a tightly-closed room.

Follow local applicable laws and regulations when disposing of the lithium battery or the toner cartridge.

This page intentionally left blank

1.4 Moving and Rotating Parts



Precautions

To prevent accidents involving moving or rotating parts during servicing, that disconnect the power cord before starting disassembly.

When you must service the fax with the power cord plugged in, you must not wear bracelets, necklaces, neckties, or other objects. Also, take care to prevent hair and other articles of clothing from becoming entangled.

The fax is provided with a protection function which stops moving and rotating parts in the printer, when the printer cover is opened during operation. However, if these sensors have to be moved when carrying out servicing with the power cord plugged in, moving and rotating parts will operate even with these covers open.



NOTE

Since this fax does not have a sensor to detect when the right cover or left cover is removed, even if you open the front cover or rear cover while this fax is operating, the gears and rollers continue to move.

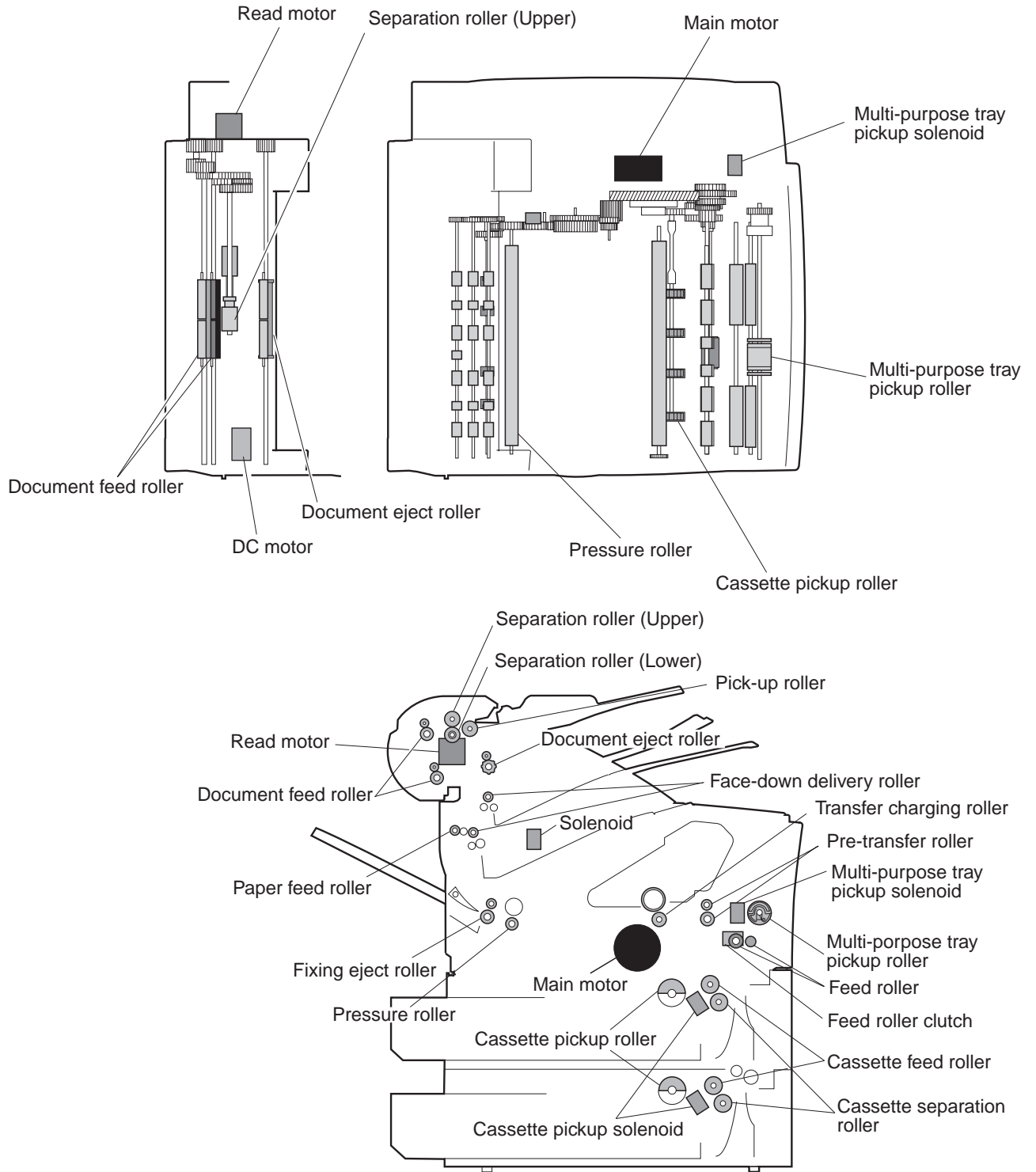

Figure 1-3 Moving and Rotating Parts

1.5 Laser Beams

This fax is a Class 1 Laser Product as defined in the EN60825 (IEC825) Radiation Safety of laser products, equipment classification, requirements and user's guide. This means that this product uses lasers that do not radiate dangerous laser beam and conforms to the regulations because the laser beam does not affect the user during operations.



Warning

If the LASER light gets in your eyes, it will damage the retina. Figure 1-4 is a LASER beam warning label which is placed on the LASER/scanner unit. Always remain within the contents of this manual when servicing, and do not carry out any other maintenance. Within the range of service work in this manual, you will not be exposed to dangerous LASER light.

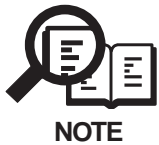

Figure 1-4 LASER beam warning label



Disassembly Prohibited

Never disassemble or alter the printer section laser/scanner unit. There is no servicing that requires you to disassemble the laser/scanner unit.



Safety Mechanism

This fax is designed with a structure such that the laser shutter only opens when the toner cartridge has been inserted into this fax. This keeps the laser from operating other than during normal operations.

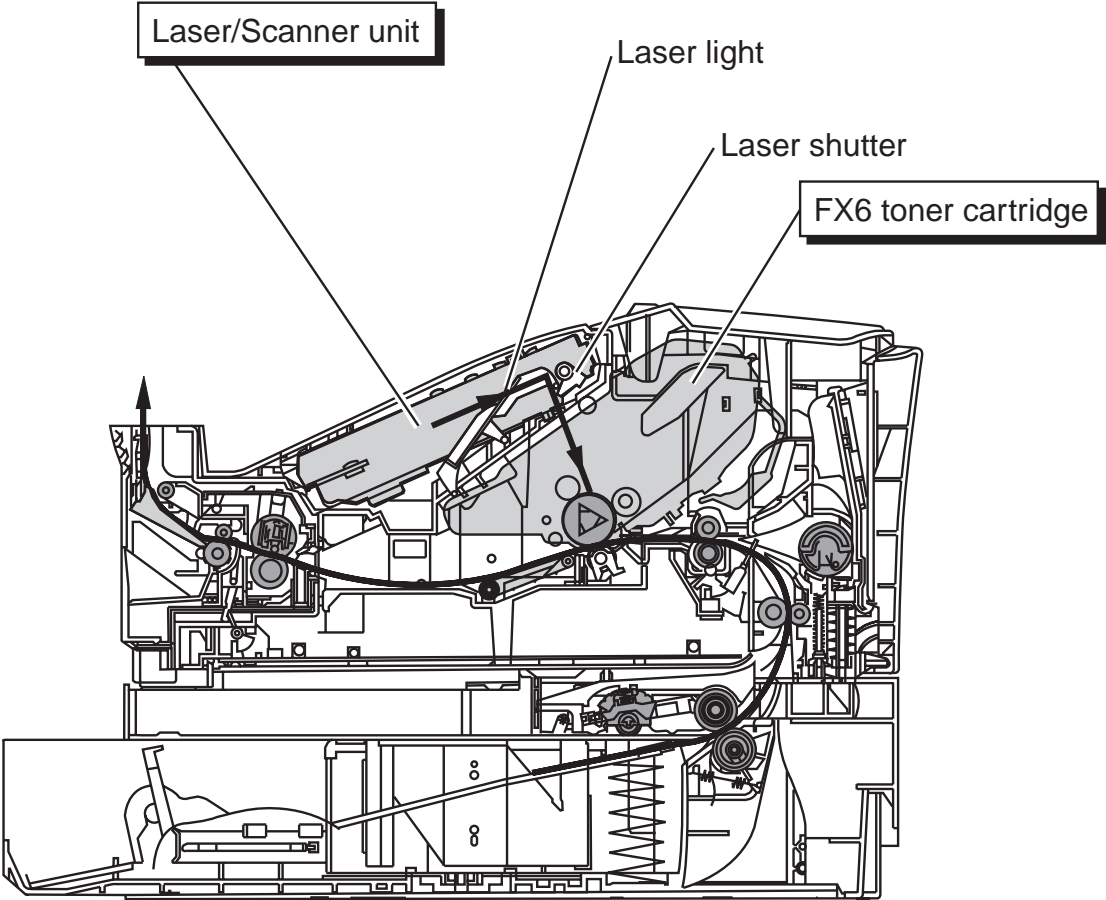
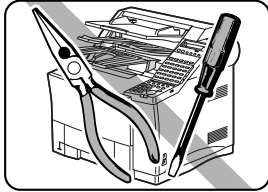

Figure 1-5 Laser Shutter

2. DANGER TO EQUIPMENT

2.1 Handling the FAX

General Precautions



- ❑ TO AVOID SERIOUS INJURY, NEVER DISASSEMBLE THE FAX. EXPOSED POWER POINTS INSIDE THE FAX CAN CAUSE ELECTRICAL SHOCK IF YOU TOUCH THEM.



- ❑ After you unplug the fax unit, always wait at least 5 seconds before you plug it in again. Always unplug before you move the fax.

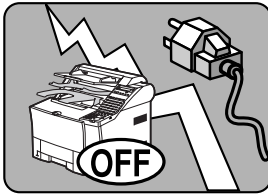

- ❑ During electrical storms, disconnect the plug from the power outlet. The fax can hold documents in the memory for up to 12 hours.

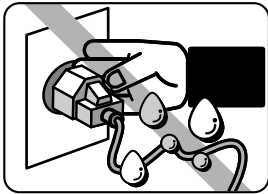

- ❑ Before you attach or remove the plug from the power outlet, make sure your hands are dry.

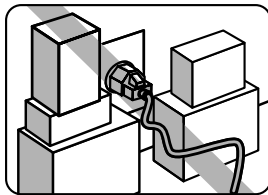

- ❑ Do not stack boxes or furniture around the power outlet. Keep the area open so you can reach the outlet quickly. If you notice anything unusual (smoke, strange odors, noises) around the fax, turn the fax off immediately and unplug it. Call for service.

Figure 1-6 Precautions 1

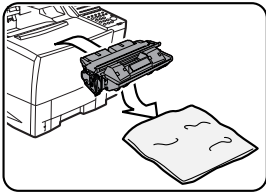

- ❑ Before you transport the fax, remove the cartridge. To protect the cartridge from bright light, cover it with its original protective bag or a cloth.

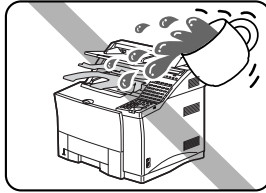

- ❑ Keep liquids, cleaners, and other solvents away from the fax unit. Keep metal pins, paper clips, staples and other objects away from the fax. If something falls into the fax unit, remove the plug from the power outlet, and call for service.

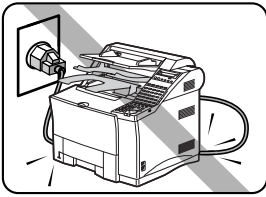

- ❑ Do not set the fax unit, other equipment, or furniture on the power cord. Never knot the power cord or wrap it around another object.

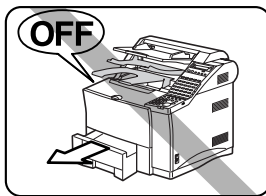

- ❑ To avoid paper jams, never unplug the power cord, open the printer cover or remove a paper cassette during printing.

Figure 1-7 Precautions 2

2.2 Storage and Handling of FX6 Toner Cartridge

Whether the cartridge is still sealed in its box or installed in the printer, the effect of the natural environment will change it over time regardless of the number of prints. As the progression of this natural change depends on the storage or installation environment, take sufficient care in storing and handling the cartridges.

2.2.1 Before unsealing the box

When the cartridge is stored in a warehouse, workshop, etc., be sure to keep it within the ranges shown in Table 1-1. Note the following points:

- a) Avoid locations in direct sunlight.
- b) Do not leave in areas exposed to strong vibration.
- c) Do not bump or drop.

Table 1-1 Environmental conditions

Temperature	Normal (total storage time ×9/10)		0 °C to 35°C (32°F to 95°F)
	Severe (total storage time × 1/10)	High	35 °C to 40°C (95°F to 104°F)
		Low	-20°C to 0°C (-4°F to 32°F)
Temperature change (within 3 minutes or so)			40°C→15°C (104°F to 59°F) -20°C→25°C (-4°F to 77°F)
Relative humidity	Normal (total storage time × 9/10)		35 to 85% RH
	Severe (total storage time 1/10)	High	85 to 95% RH
		Low	10 to 35% RH
Air pressure			613 to 1013 hPa (460 to 760 mmHg)



NOTE

Total storage time is the valid time span following the manufacture date displayed on the cartridge box.

2.2.2 Storing unsealed parts

As an organic photoconductor (OPC) is used in the photosensitive drum, it will deteriorate if exposed to strong light. As there is also toner in the cartridge, be sure to explain to the customer the need to be careful in handling and storing unsealed cartridges.

2.2.3 Storage environment

- a) Be sure to store in the protective bag.
- b) Avoid locations exposed to direct sunlight, near windows, etc. Do not leave the cartridge in cars for any extended period of time as heat can damage it.
- c) Avoid high, low, and changeable temperature/humidity locations.
- d) Avoid sites with corrosive gases (pesticides) or salt in the air.
- e) Store the cartridge within a range of 0°C (32°F) to 35°C (95°F).
- f) Do not place the cartridge near CRT displays, disk drives, or floppy disks.
- g) Store the cartridges out of reach of children.

2.2.4 Effective life

Cartridges are effective for 2.5 years following the date of manufacture, which is displayed in an abbreviated form on the cartridge. The cartridge life span is also displayed (month and year) on the cartridge box as 2.5 years from the date of manufacture. Cartridges should be used within their life spans, as image quality will deteriorate after the expiry date.

2.2.5 Handling

- (1) When loading a new cartridge into the printer, or when blank spots appear on output images due to uneven distribution of the toner during use, hold the cartridge at each end as shown in the figure below. Slowly rock it 5 to 6 times at a 45-degree angle to evenly distribute the toner, and reload it into the printer. Do not shake the cartridge in any other ways, as toner may leak from the developing cylinder or the cleaning unit.

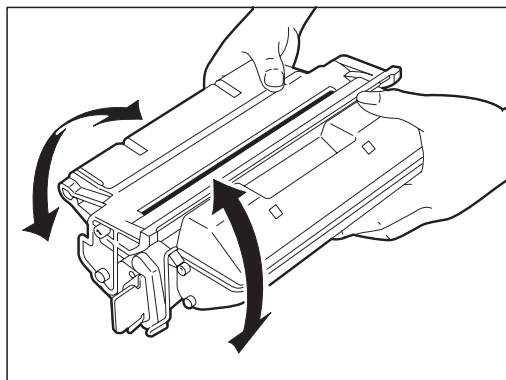

Figure 1-8 Proper Way to Shake Cartridge

After loading the cartridge in the printer, print 3 to 5 sheets of test patterns and check for toner leakage to prevent output image from dirt.

- (2) Remove the cartridge from the printer before transporting it. During transportation, the cartridge must be kept in the protective bag or thick cloth to prevent direct exposure to light.
- (3) Avoid placing the cartridge near CRT displays, disk drives or floppy disks, as the magnetism generated by the cartridge may destroy the data.
- (4) As the photosensitive drum is sensitive to strong light, do not expose the cartridge to direct sunlight or strong light. If it is exposed to strong light, blank spots or black lines may appear on images. In such cases, stop the printer for a while. However, these problems may still remain if the drum has been exposed to strong light for an extended period of time.
- (5) Do not open the photosensitive drum protective shutter by hand nor touch the drum surface. Do not clean the drum.
- (6) Do not stand the cartridge nor upside down. Always place it so that the label side faces upward.
- (7) Do not disassemble the cartridge.

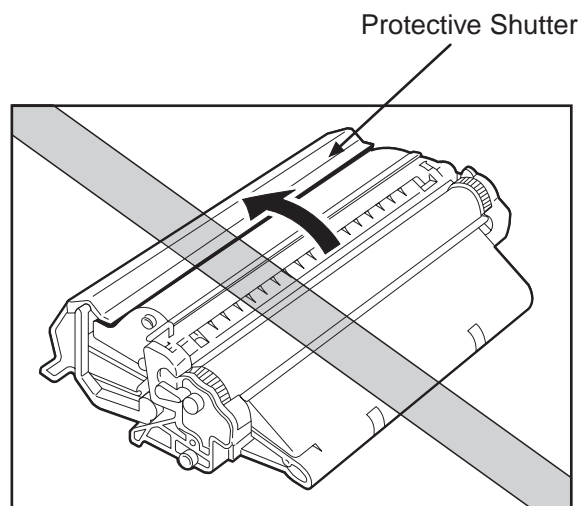

Figure 1-9 Cautions for Handling

2.3 Precautions when Servicing

2.3.1 Damage due to electrostatic discharge

This fax contains contact sensor and printed circuit boards that use many electrical components such as ROM, RAM and custom ICs. A static charge can damage these components, so, care must be taken to prevent damage caused by electrostatic discharge when disassembling the fax.



Static electricity

Electrostatic discharge damages electronic components and alters their electrical characteristics. Even plastic tools and hands without grounding wrist straps will generate enough static electricity to damage electronic components.

The following equipment is needed to prevent electrostatic discharge damage:

- An earthed conductive mat
- Grounding wrist straps
- Alligator clip cable for earthing metal parts on the fax

Carry out the following countermeasures if the above equipment is not available, (for example, during on-site servicing):

- Use an anti-static bag for storing or carrying printed circuit boards or electronic devices.
- Avoid wearing silk or polyester clothing, or leather-soled shoes. Wear cotton clothing and rubber-soled shoes.
- Avoid servicing the fax in carpeted rooms.
- Before starting servicing, touch grounded earth terminals to discharge any static electricity charges.
- Wear grounding wrist straps, and earth metal parts on the machine.
- Handle printed circuit boards and electronic devices by their edges and packages. Do not directly touch terminals of electronic devices with your fingers.



Electric shock when carrying out work with the fax turned on

When you must service the fax with the power cord plugged in, you must not ground your body with grounding wrist straps. This is to prevent electricity passing to your body and causing electric shock.

2.3.2 Lubrication points

Do not touch the greased parts. If you do, the grease (applied for smooth operation of the printer mechanism and to increase electrical conductivity) will come off.



Use only specified grease.

If you use other grease, the grease may oxidize, and weaken plastic parts.



REFERENCE

If you accidentally touch a greased part and grease comes off, reapply the grease, see the *PARTS CATALOG (supplied separately)*.

2.3.3 Scanner section

a) Contact sensor

Handle the contact sensor carefully to avoid scratching or dirtying its scanning surface. Scratches or dirt on the scanning surface can cause vertical stripes or other defects to appear in the scanned image.

Also, if the contact sensor scanning section is exposed to external light for prolonged periods, its characteristics deteriorate, resulting in blackish scanned images. During servicing, do not expose the contact sensor scanning section to external light for prolonged periods.

b) Auto document feeder (ADF) rollers

Handle the ADF section rollers to avoid scratching or dirtying them. If they are scratched or dirtied, vertical stripes or other defects may occur in the scanned image and the document may jam.

If the roller is dirtied, clean it with a soft, dry cloth.

c) Plastic film

Do not modify the plastic film (white sheet unit) which presses down the document in the middle frame unit of the reader assembly.

Document jams may occur if it is modified.

d) Stamp Ink supply

Fill with one drop of stamp ink so that it does not overflow the edge of the stamp. The operation of the stamp may be degraded if the ink overflows and drips down.

e) Middle reader frame unit stopper

Do not force the middle reader frame unit open with the stopper removed. If unnecessary strength is used, the hinge of middle reader frame unit will be damaged.

2.3.4 Printer section

a) Transfer charging roller

If skin, oil or, the like, gets on the rubber section of the transfer charging roller, the rear side of the recording paper can be soiled, and blank patches can occur in printing. During disassembly, hold the shaft at both ends of the transfer charging roller.

b) Fixing ass'y

If you get skin, oil, or the like, on the internal fixing film or pressure roller surface, the front or rear of the recording paper may be soiled, and fixing defects, and jams can occur. During disassembly, hold the fixing ass'y by the metal plate sections. Hold the pressure roller by the shaft at both ends of the roller.

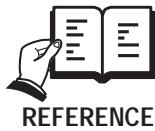

Cleaning method

For details of how to clean these parts, see *Chapter 4, 3. CLEANING*.

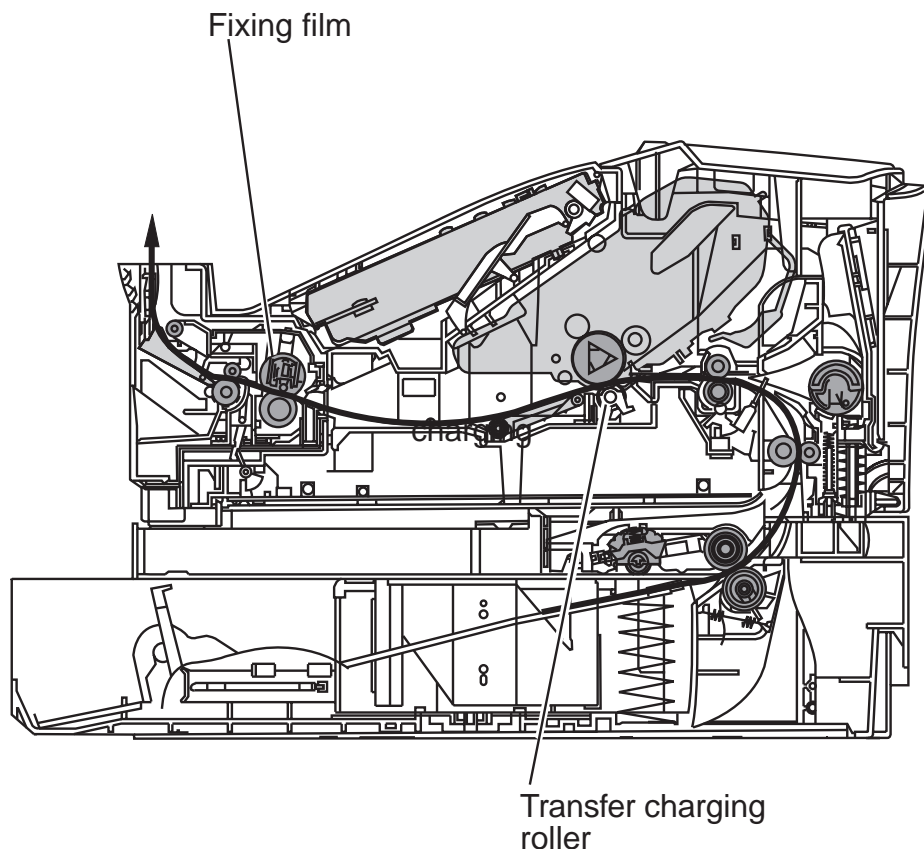

Figure 1-10 Printer Section

2.3.5 Paper load section

a) Pickup Roller Position

When having assembled the paper pickup roller after parts replacement, before setting the cassette 1 or the cassette 2, install the toner cartridge, close the printer cover, connect the power cord, and the cassette pickup roller moves automatically to its initial position.

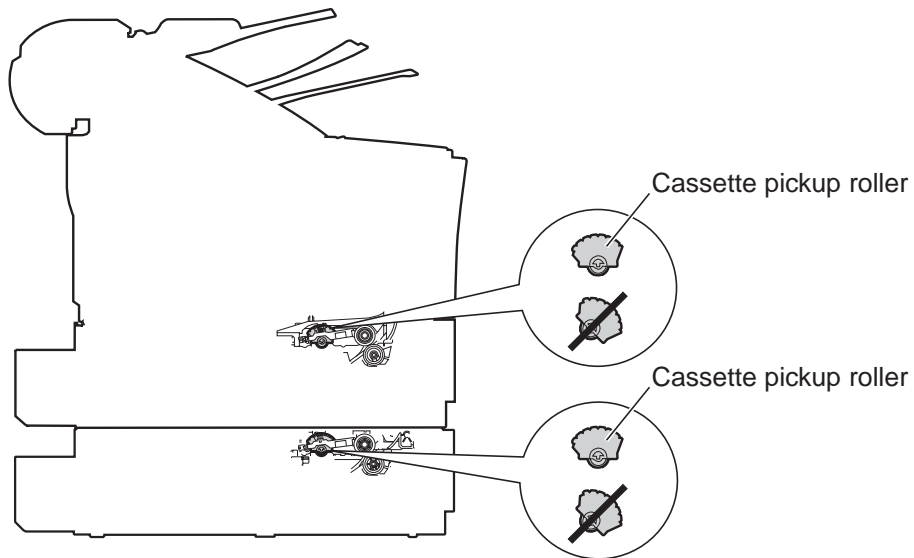

Figure 1-11 Pickup Roller Initial Position

2.3.6 Control boards

a) SCNT board

Jumper plug JP3 and J6 are for factory check only. Service technician must not remove it.



REFERENCE

SCNT board data

User data, service data are stored in memory on the SCNT board. Therefore, these data must be printed out before replacing the SCNT board.

For details, see *this Chapter, 3. PRECAUTIONS FOR DATA PROTECTION.*

b) Power supply unit

The RV1 and RV2 are for factory adjustment only. Service technician must not change these settings.

c) ECNT board

The VR601 is for factory adjustment only. Service technician must not change this setting.

d) Laser scanner unit

The VR501, VR502 and VR503 are for factory adjustment only. Service technician must not change these settings.

2.3.7 Replacing ROM

Observe the following precautions when replacing the ROM on the SCNT board, for example, when replacing a defective ROM or when upgrading the software.

a) Preparation

Print out all battery backed up data.



Reception image data in image memory is erased approx. 12 hours after power is turned off.

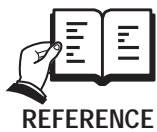

For details on battery backed up data, see *this Chapter, 3. PRECAUTIONS FOR DATA PROTECTION.*

b) Replacement

- (1) Make sure that the power cord and the telephone line are disconnected.
- (2) Put on the grounding wrist straps to counter electrostatic discharge.
- (3) Remove the right cover, and shield cover referring to the *PARTS CATALOG (supplied separately)*.
- (4) Remove the ROM mounted on the SCNT board using the IC removing tool.
- (5) Insert the new ROM, making sure that the notches on the ROM and IC socket are aligned.

c) After replacement

- (1) When a defective ROM is being replaced with a new ROM, turn the power on after mounting on the SCNT board. This completes replacement.
- (2) When the ROM is replaced for upgrading the software and upgrading involves changing software switch settings such as service data, you must perform the following operation.
 - Perform All Clear operation. After you perform All Clear operation, register the backed up data referring the list you printed out earlier.

3. PRECAUTIONS FOR DATA PROTECTION

3.1 Battery-backed up Data

The SCNT board is provided with a function for backing up data in control processing memory (SRAM) and image storage memory (DRAM) by lithium battery, and rechargeable battery, even if a power interruption occurs, or the power cord is disconnected by accident.



The back up time for image data with the secondary vanadium-lithium battery is approximately 12 hours. When the back up time is exceeded, the image data is deleted. Please print out the data before shutting off the power. If the reception image data cannot be printed out due to printer engine trouble, transfer the stored reception image data to another fax. For details, see *this Chapter, 3.2.2 Reception image data transfer*.

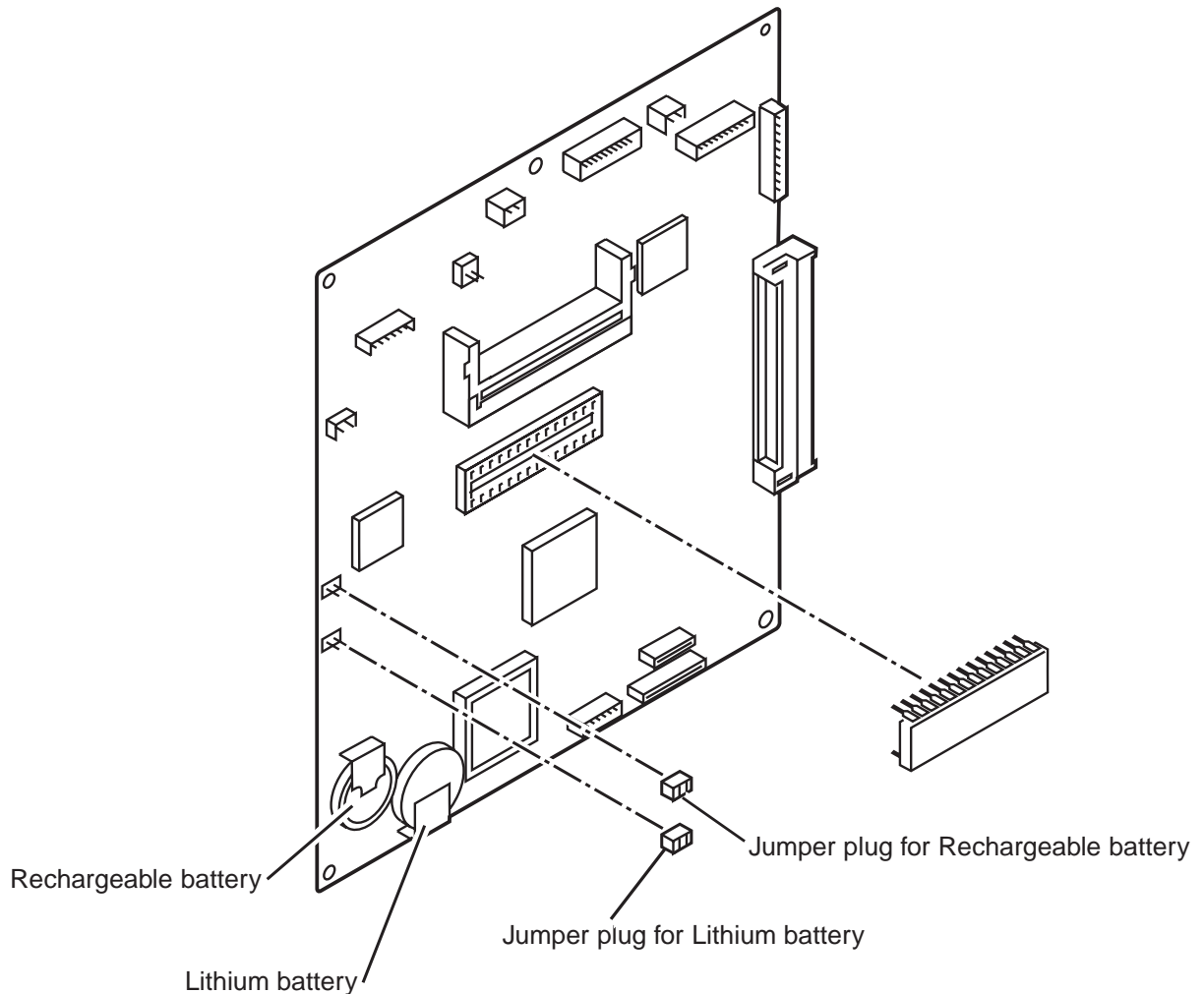

Figure 1-12 Lithium / Rechargeable Battery and Jumper Plugs

3.2 Backed up by Rechargeable Battery

The data stored in the image memory on the SCNT board is backed up for about 12 hours by the secondary vanadium-lithium battery.

3.2.1 Data backed up by rechargeable battery

Image data stored in the DRAM:

Image	Mode
Transmission images	Memory transmission
	Sequential broadcasting
	Delayed (broadcast) transmission
	Confidential transmission
	Polling transmission
	Relay control transmission
	Relay broadcast transmission
Reception images	Memory reception
	Confidential reception

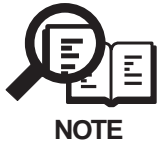

Memory clear list

If the power is turned on after the rechargeable battery backup time has been exceeded, the memory clear list is automatically printed out. The memory clear list is a list of image data that have been cleared from memory. If the memory clear list cannot be printed due to printer engine trouble or run out of paper, the fax sounds alarm, information for managing the storage status of image data is erased from memory, then goes on standby. The operation that is carried out when the memory clear list cannot be printed can be altered by changing the setting of SSSW SW02 bit 0. For details, see *G3 Facsimile SERVICE DATA HANDBOOK (Rev. 0) (supplied separately)*.

After the memory clear list is printed out, information for managing the storage status of image data is automatically erased from memory.

Conditions for image backup

1) Reception images

If power is interrupted during reception, only pages that have completely been received are backed up, and the page that was in the process of being received during the power interruption is deleted.

2) Transmission images

Only memory transmission images (including during standby for redial) are backed up, and direct transmission is canceled.

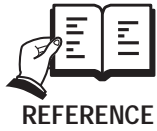

For a sample printout of the memory clear list, see *Chapter 2, 3.1 Report Output Function*.

3.2.2 Reception image data transfer

The received image data cannot be printed out due to printer engine trouble, the received image data can be transferred to another fax and printed.

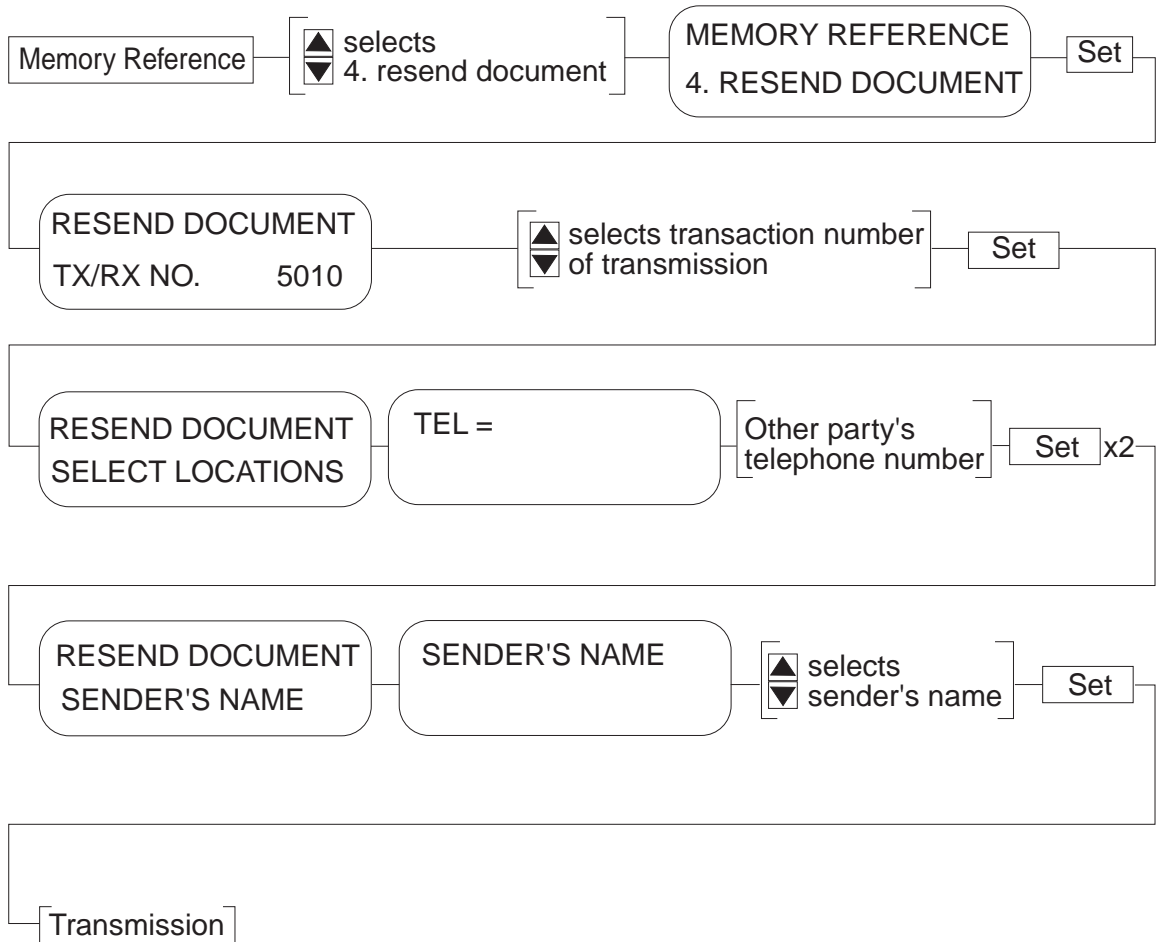

Figure 1-13 Reception Image Data Transfer Method

3.3 Backed up by Lithium Battery

The lithium battery backs up control data registered in the SRAM on the SCNT board for five years with the power turned off.

However, when the power is ON, there is no discharge of power from the lithium battery, so the actual life of the battery will be over 5 years.

3.3.1 Data backed up by the lithium battery

a) User data

Data input by the user with the Data Registration button on the operation panel.

Item	Description
1. DATA REGISTRATION	USER SETTING (Date/time, user telephone registration, etc.)
	REPORT SETTING (Activity report, etc.)
	TX SETTINGS (ECM Tx, automatic redial, etc.)
	RX SETTINGS (ECM Rx, remote reception, etc.)
	FAX'S PRINTER SET (Recording paper selection, reception image reduction, etc.)
	FILE SETTINGS (Confid. mailbox, memory box, etc.)
	SYSTEM SETTINGS (Rx restriction, display language, etc.)
2. TEL REGISTRATION	ONE-TOUCH SPEED DIAL
	CODED SPEED DIAL
	GROUP DIAL

b) Service data

Data input by the service personnel with the Data Registration button, and # button, on the operation panel.

Item	Description
#1. SSSW	Error management, echo counter measures, etc.
#2. MENU	NL equalizer, transmission level, etc.
#3. NUMERIC Param.	RTN signal transmission condition, etc.
#4A. SPECIAL	Normally not used
#4B. NCU	Normally not used
#4C.ISDN	ISDN line control function settings, etc.
#5. TYPE	Normally not used
#6. GENESIS (UHQ)	Normally not used
#7. PRINTER	Reception image reduction conditions, etc.
#8. CLEAR	The total number of pages printed/scanned

c) Management data

Data automatically stored as a record of the operating status.

Item	Description
Activity report	Transmission/Reception records for last 40 communications
System dump list	A record of past communication conditions, error communication, etc.



NOTE

When data have been erased or initialized

When backed up user or service data have been erased or initialized, the registered data are erased, and the data item is set to its factory setting.

3.3.2 Printing the lithium battery backup data list

The following data are backed up by lithium battery and can be printed out as a list.



When to print out

Make sure that you print out a list of the following data before replacing the lithium battery, or before removing the jumper plug (JP2) from the SCNT board with the power turned off.



REFERENCE

How to print data

For details on how to print out the following lists, see *Chapter 2, 3.1 Report Output Function*.

a) User data

Item	List Name
User's data	User's data list
Tel registration	1-touch spd dial list 1, 2 Coded speed dial list 1, 2 Group dial list
Sender name	Sender name

b) Service data

Item	List Name
Service data	Service data list

c) Management data

Item	List Name
Activity management data	Activity report
System dump data	System dump list



Jumper plug caution

The lithium battery backup function works when jumper plug JP 2 on the SCNT board is shorted by a jumper plug. This means that registered data will be erased when the power cord is disconnected with the jumper plug removed. Before removing the jumper plug, make sure that you print out all registered data. The fax is shipped from the factory with the jumper pin shorted by the jumper plug.

Cautions when replacing the SCNT board

Before replacing the SCNT board during servicing, make sure that you print out all registered data.

The SCNT board in the service parts is not provided with a jumper plug (JP2), in order to prevent battery discharge. Therefore, use the jumper provided on the SCNT board that is to be replaced.

When you turn the power on after replacing the SCNT board, “DELETE FILE PRESS SET KEY” will be displayed. When you press the **Set** button with “DELETE FILE PRESS SET KEY” displayed, the image management data in the SRAM is cleared. Then “DATA ERROR PRESS SET KEY” will be displayed. When you press the **Set** button with “DATA ERROR PRESS SET KEY” displayed, the user and service data in SRAM will be initialized to their original factory settings. Next, register the data from the old SCNT board, referring to the print out.

Lithium battery replacement cycle

The life of the lithium battery is five years with the power turned off.

However, when the power is ON, there is no discharge of power from the lithium battery, so the actual life of the battery will be over 5 years.

When the lithium battery reaches the end of its life, “DELETE FILE PRESS SET KEY” or “DATA ERROR PRESS SET KEY” will be displayed after a power interruption, or when the power is turned on. If this happens, replace the lithium battery.

When you replace the lithium battery, all the backed up data will be erased and there will be nothing to print out.

When you turn the power on after replacing the lithium battery, “DELETE FILE PRESS SET KEY” will be displayed. When you press the **Set** button with “DELETE FILE PRESS SET KEY” displayed, the image management data in the SRAM is cleared. Then “DATA ERROR PRESS SET KEY” will be displayed. When you press the **Set** button with “DATA ERROR PRESS SET KEY” displayed, the user and service data in SRAM will be initialized to their original factory settings.

3.4 Data clear/initialization using Service Operation

This fax can clear/initialize individual data items with Service Data #8 Clear operation. Below are the data items which can be cleared/initialized.



When to print out

Before carrying out this operation, make sure that you make print out a list of backed up data.



REFERENCE

Operation

For details on the following items, see *Chapter 2, 3.3.2 Service Data Setting*.

Service Item	Description
TEL	Dialing data
USER SW	User data, Service data #1 to #3
SERVICE SW	Service data #1 to #3, #6, #7
NCU	Service data #4A, #4B
ISDN	Service data #4C
SERVICE DATA	Data on system dump list
COUNTER	Total number of pages printed and scanned
REPORT	Data on activity report
ALL	All user data, service data, activity management data and image data (except COUNTER)

3.5 Master Password

This fax has a password for confidential box setting changes and deletions, and passwords for managing each department.

For service operations and for when the user forgets a password, there is a master password.

Master password: 4559769

The master password can substitute for the passwords required for the following items.

Operation item	Contents of operation
Confidential box password	Confidential box setting changes/deletion, reception image printing.
Polling box password	Polling box setting changes/deletion.
Transfer password	Transfer function setting changes/deletion.
Memory box password	Memory box setting changes/deletion, reception image printing.
Relay TX group password	Relay TX group setting changes/deletion.
Delayed polling box password	Delayed polling box setting changes/deletion.
System setting password	System setting password.
User password	Change to the transmission function settings of the user restriction setting item and print settings.
Memory reference	When password required for memory reference print document memory.



Master password user restriction

The master password can only be used by service technician. To avoid unauthorized use, do not tell the user the master password. The master password is not in the *USER'S GUIDE*.

3.6 What to do when a Problem Occurs (All clear)

Very rarely, during use, the display may go out, all the buttons may stop working, or some other trouble may occur because of strong electrical noise or strong shock. If such trouble occurs, perform All clear operation.

During installation, we recommend that you perform All clear operation. Below is the procedure for performing All clear.

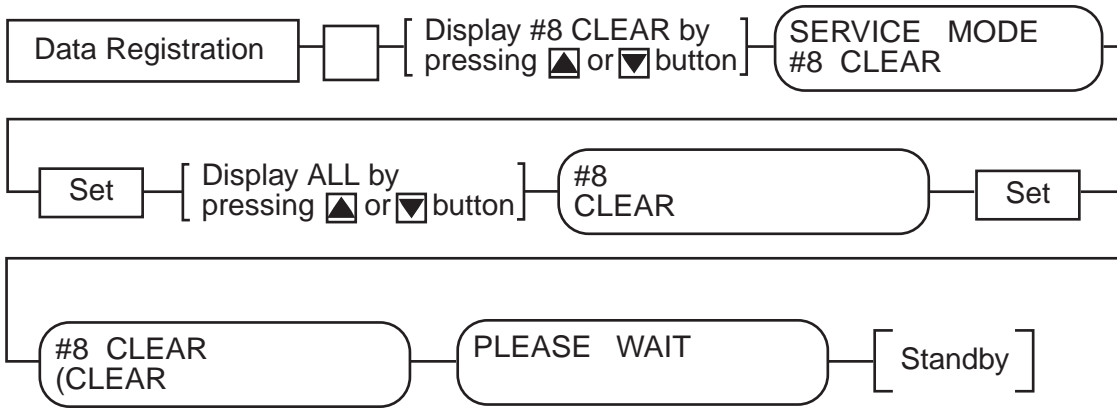

Figure 1-14 All Clear



While waiting to return to the ready state after executing “All clear”, please do not press the Stop button. Doing so may cause a malfunction afterwards.

4. PROTECTIVE FUNCTIONS

4.1 Reception Image Data Transfer Function

Reception image data can be transferred to another fax if the image data cannot be printed out due to printer engine trouble.



REFERENCE

Reception image data transfer

For details on the transfer of image data, see *this Chapter, 3.2.2 Reception image data transfer*.

4.2 Data Battery Backup Function

The SCNT board is provided with a function for backing up data in control processing memory (SRAM), and data stored to image memory (DRAM), by lithium battery and rechargeable battery, even if power is interrupted, or the power cord is disconnected by accident.



REFERENCE

Backed up data

For details on backed up data, see *this Chapter, 3.2 Backed up by rechargeable battery and 3.3 Backed up by lithium battery*.

4.3 Built-in Safety Measures

4.3.1 Overcurrent protection

This fax is provided with an overcurrent protection circuit with built-in current fuse and thermal fuse, to prevent abnormal rises in temperature if an overcurrent flows to the motors and power supply due to driver IC trouble, software lockup and short circuits.

Protected Parts	Safety Measures
Document read motor	IC protector (FU2) on SCNT board
Stamp unit (option)	Current fuse (FU1) on SCNT board
Power supply unit	Glass-tube current fuse (F1 (125V, 15A), F2 (125V, 6.3A)), overcurrent protection circuit
Fixing heater	Thermal fuse (446°F/230°C), thermistor

4.3.2 Lightning protection

This fax is provided with a function for protecting electronic components from abnormal voltage caused by lightning.

Protected Parts	Safety Measures
NCU board ass'y	Arrestors (AR1, AR2) located at the primary side of the NCU board discharge a voltage of more than DC 320 to 350V via the telephone line or the power cord.
Power supply unit	Surge-absorber (NR3) located at the primary side of the power supply unit goes into short-mode at a voltage of more than 423V, and breaks. After this, the glass-tube current fuse F2 or F1 blows.

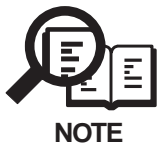

When protection is not possible

The NCU board sometimes may not be protected even by the protection circuits if lightning strikes the telephone line.

4.3.3 Power leakage protection

The AC line, telephone line and metal parts of this fax are completely insulated. This fax provides a grounding type (three-wire) power supply cable to prevent electrical shock. Even if electrical leakage should occur, use this fax only with a properly grounded electrical outlet of the correct voltage.

5. QUALIFICATION REQUIRED FOR INSTALLATION WORK

The qualifications for installation must satisfy local laws and regulations.

Chapter 2

Operating Instructions

1. NAMES OF PARTS AND THEIR FUNCTIONS

1.1 Main Unit Overview

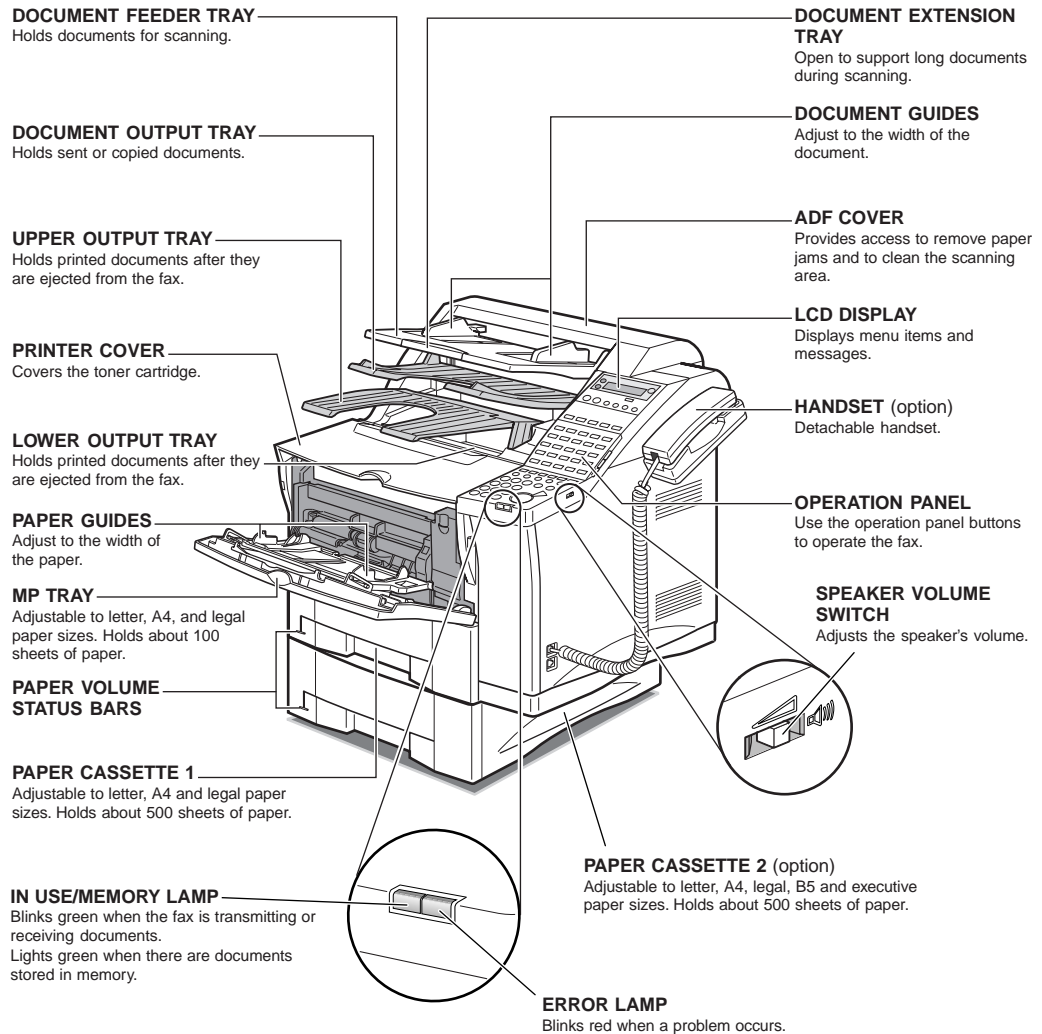

Figure 2-1 Front View



NOTE

This fax does not have a power switch.

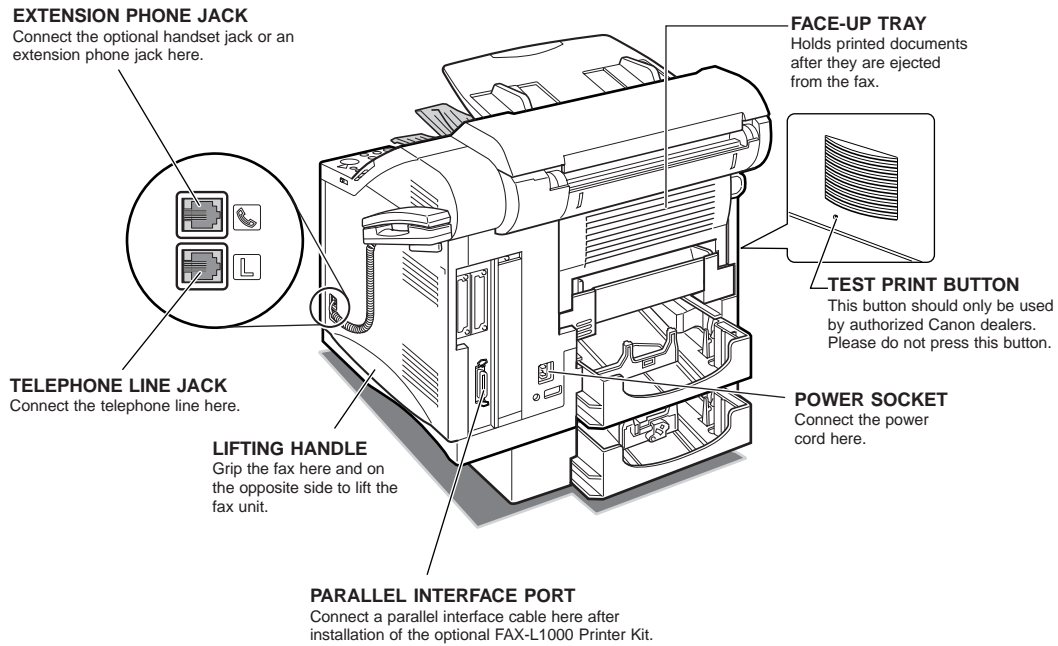

Figure 2-2 Rear View

This page intentionally left blank

1.2 Operation Panel

LCD Display

Displays messages and prompts during operation. Displays selections, text, numbers and names when registering information.

Change Cartridge

Lights when toner in the toner cartridge runs low. Replace the toner cartridge.

Rec. Paper

Lights when the paper cassettes run out of paper. Re-fill the cassettes with paper.

Printer Operation Panel

Used for printer function. For details, refer to the Printer User's Guide supplied with the optional FAX-L1000 Printer Kit.

Resolution

Sets the resolution for documents you send.

Contrast

Adjusts the lightness/darkness of documents you send or copy.

Document Type

Adjusts quality for documents with only text or with both photos and text.

One-touch Speed Dialing Buttons

Dial numbers registered under One-touch Speed Dialing buttons.

One-touch Speed Dialing Panels

The first panel displays buttons 1-25. Open the first panel to access buttons 26-50. Open the second panel to access buttons 51-72. Open the third panel to access the registration buttons.

Program

Registers multi-step setting normally done by pressing buttons on the operation panel so you can do them at the press of single button.

Transaction

Displays information about previous sending and receiving transactions.

Delete File

Deletes documents waiting in memory for sending.

R

Press to dial an outside telephone number, or an extension number, when the fax is connected through a switchboard (PBX).

Numeric Keypad

Use the buttons on the numeric keypad to enter phone numbers when dialing. These buttons also enter text, numbers, and symbols when registering names and numbers.

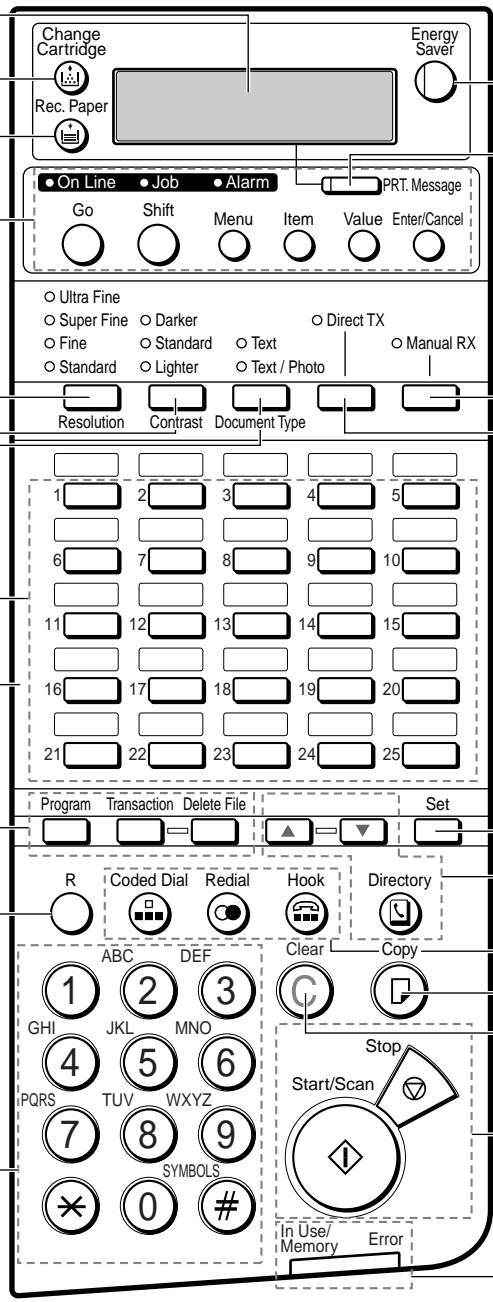

Figure 2-3 Operation Panel 1

Energy Saver

Switches the fax out of the energy saver mode.

PRT. Message

Switches the LCD display between the fax messages and the printer messages.

Manual RX

Switches the fax between the auto and manual receive mode.

Direct TX

Sets the fax in the direct sending mode so you can send a document ahead of other documents stored in the fax memory. Direct sending scans a document and sends it immediately without storing the document in the memory.

Set

Selects a menu item during data registration.

Directory

Allows you to search for fax/telephone numbers by the name under which they are registered for speed dialing and then use the number for dialing.



Search buttons for directory dialing.

Coded Dial

A press on the button followed by a three-digit code dials the telephone number registered for Coded Speed Dialing under that three-digit code.

Redial

Redials the previous number dialed manually with the buttons on the numeric keypad.

Hook

Allows you to dial, even with the handset still in the handset rest.

Copy

Copies a document.

Clear

Clears an entire entry during information registration.

Stop

Cancels sending, receiving, data registration, and other operations and returns the fax to the standby mode.

Start/Scan

Starts sending, receiving, copying and other operations.

Error

Blinks red when paper jam occurs or the fax is running out of paper or toner. The problem is described by a message in the LCD display above.

In Use/Memory

Blinks green when the fax is using the telephone line. Lights green when there are documents in the memory.

Figure 2-4 Operation Panel 2

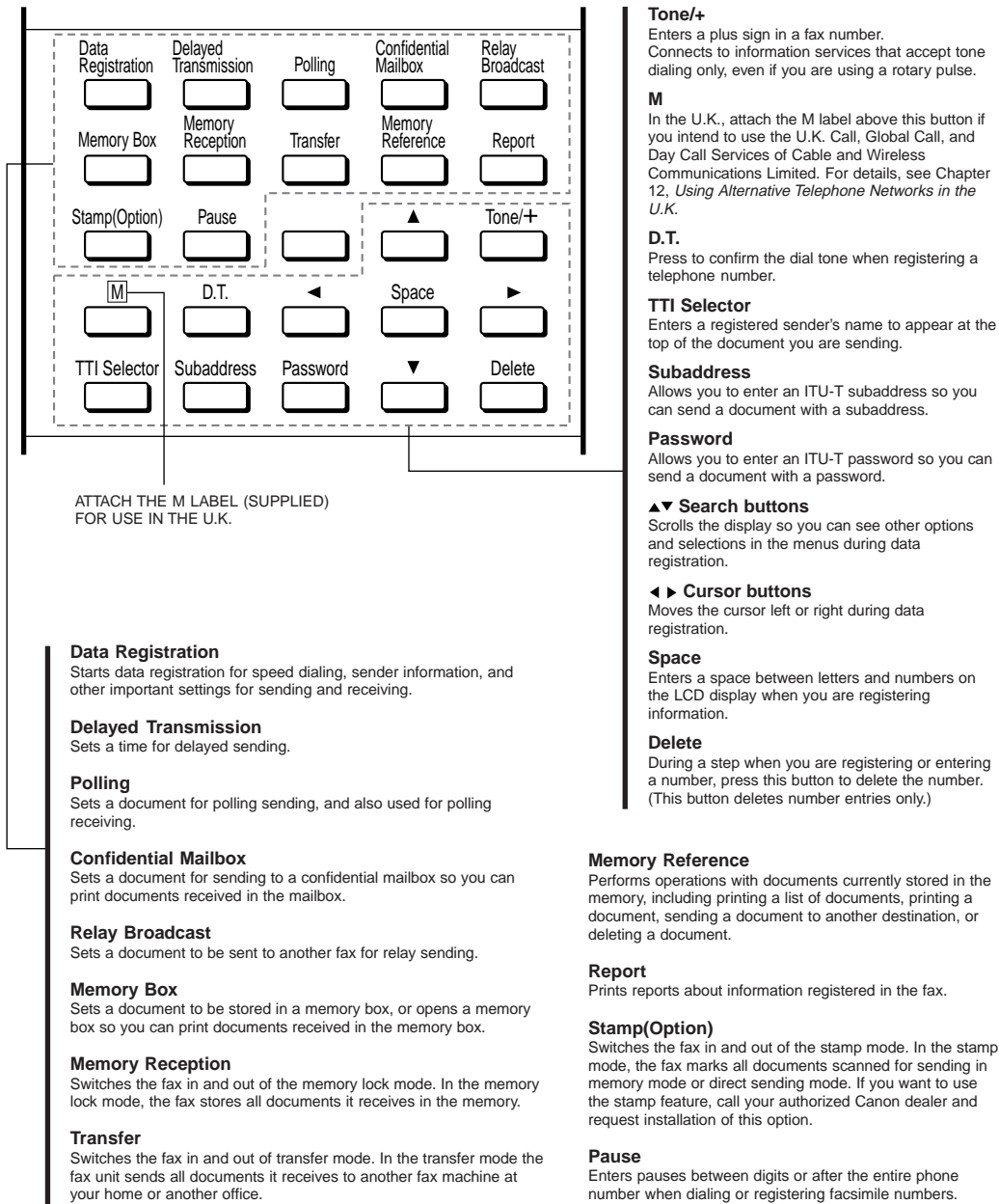

Figure 2-5 Operation Panel 3

2. BASIC OPERATION

2.1 Copying

- (1) Set the recording paper



NOTE

Refer to *Chapter 5, 1.4 Assembling the Fax, Loading Paper in Paper cassettes 1 and 2* for the method of setting the recording paper.

- (2) Set the document face up on the document feeder tray
Adjust the document guides to match the width of the document. With a long document, open the document extension tray.
Make sure the document is below the load limit marks for A4/LTR and B4/LGL sizes.
- (3) Document insertion
Insert the document until it makes contact with the stopper. A “beep” will sound.



NOTE

When the document is set, the amount of memory used will be displayed, and then a message will appear indicating that the document has been set.

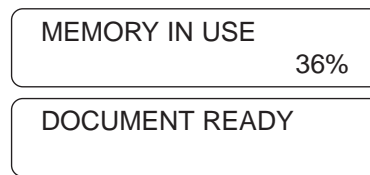

Figure 2-6 Display for document set

- (4) Press the Copy button.
- (5) Open all three of the one-touch panels and select the recording paper with the ▲ or ▼ button.
When using the displayed recording paper, simply proceed to the next step.
- (6) Set the number of copies with the numeric key. (Max. 99 copies.)
- (7) Press the Start/Scan button.

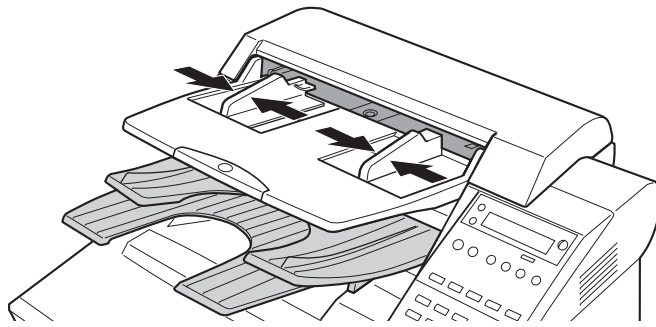

Figure 2-7 Document Guides Adjustment

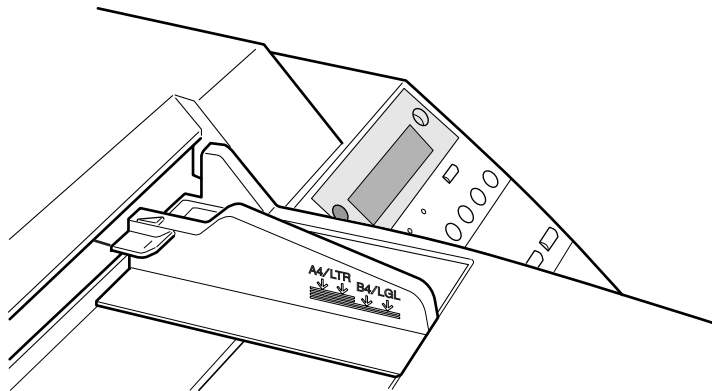

Figure 2-8 Document Load Limit

2.2 Telephone (Only possible where a handset or telephone are connected)

- (1) Lift the handset or telephone receiver.
The sound of dial tone will be heard.
- (2) Dial the other party's telephone number using the dial button on the main unit or the telephone.
- (3) Have the telephone conversation if the other party's voice can be heard.

2.3 Transmission

There are two ways to transmit the document: memory transmission and direct transmission.

a) Memory transmission

The set document is read into memory and then transmitted.

Setting method

Press the Direct TX button to turn off the Direct TX LED.



NOTE

Even during memory transmission, other documents can be reserved for transmission.

b) Direct transmission

The set document is transmitted directly without being read into memory.

Setting method

Press the Direct TX button to turn on the Direct TX LED.



NOTE

Direct transmission is done in on a priority basis even when there are multiple transmission reservations in memory.

2.4 Reception

There are 3 reception methods: auto reception, manual reception, and auto reception switching.

a) Auto reception

This is set when the machine is used exclusively for facsimile. The initial condition of the machine is set to “Auto reception”.

Setting method

- (1) Select “MAN/AUTO SWITCH” with the user data registration RX setting, display “OFF” with the ▼ ▲ buttons, and confirm with the SET button.
- (2) Press the Manual RX button to turn off the Manual RX LED.

b) Manual reception

This fax will produce a calling tone no matter if the other machine is a facsimile or telephone.

When the other party is sending by facsimile, receive by pressing the Start/Scan button.

Remote reception is also possible from a connected optional handset or telephone.

Setting method

- (1) Select “MAN/AUTO SWITCH” with the user data registration RX setting, display “OFF” with the ▼ ▲ buttons, and confirm with the SET button.
- (2) Press the Manual RX button to turn on the Manual RX LED.



When receiving manually, communication with the other party is not possible unless the telephone is connected.

NOTE

c) Manual/Auto switching

When receiving manually, when the receiver is not taken off the hook within the number of seconds (F/T RING TIME) set in the user data registration settings, the machine will automatically enter FAX mode and automatic reception will begin.

Setting method

- (1) Select “MAN/AUTO SWITCH” with the user data registration RX setting, display “ON” with the ▼ ▲ buttons, and confirm with the SET button.
- (2) Press the Manual RX button to turn on the Manual RX LED.



Refer to the *USER'S GUIDE* for details regarding the various reception methods.

REFERENCE

3. SERVICE OPERATION FUNCTIONS

3.1 Report Output Function

3.1.1 User report output functions

This fax can output user reports manually by user operation, or automatically, according to user data registration.

a) Manual output of reports by user operation

Report type	Operations
One-touch dial list 1	Press Report button, select the report type, and press Set button.
One-touch dial list 2	
Coded speed dial list 1	
Coded speed dial list 2	
Group dial list	
User data list	
Sender name list	
Activity report	
Document memory list	
Confidential mailbox report	
Received memory box list	

b) Reports output automatically by user data registration

Each report written below can be automatically output by specifying "REPORT SETTINGS" in user data registration.

Transmission report
 Reception report
 Confidential reception report
 Memory box report
 Activity Report



REFERENCE

For samples of user reports, see the *USER'S GUIDE*.

c) Reports output automatically (Memory clear report)

When this fax is turned on and the memory clear report is automatically printed out, the image data which appears on the report is the data which was deleted without being able to be backed up. After the memory clear report is printed, the image data management information is automatically deleted.

12/31/1999 11:52 FAX 833 4423		WORLD ESTATE,INC.			001	
***** *** MEMORY CLEAR REPORT *** ***** MEMORY FILES DELETED						
TX/RX NO	MODE	CONNECTION TEL/ID	PGS.	SET TIME	ST. TIME	SENDER NAME
0011	TRANSMIT	[*002]HUNT INVESTMENTS	2	12/31 13:00	23:30	R.LOUIS
5011	CONFID. RX		1	12/31 14:46	----	

Figure 2-9 Memory Clear List

- TX/RX NO : Indicates four digits of the transaction number
- MODE : Displays the communication modes of TX, RX, polling TX, timer TX, etc.
- CONNECTION TEL/ID: Displays the number and each digit (24 digits) of onetouch speed dial and coded speed dial.
- PGS. : Number of pages are stored in memory
- SET TIME : Time when data is stored in memory (24-hour display)
- ST TIME : Displays a start time for delayed TX, etc. (24-hour display)
- SENDER NAME : Sender name appended to transmission (up to 24 characters)
Displays a 4-digit department code (only used when department access code setup (DAC SETUP) is "ON").

3.1.2 Service report output functions

This fax outputs the service data setting status, past communications history reports, detailed error information reports, etc. in service mode.

a) List of service reports

This fax outputs the service reports shown below.

Report type	Operations
Service data list System dump list Dch log report Bch log report	In the service mode, press the Report button, select the report type, and press the Set button. (When the optional FAX-L1000 ISDN Kit is installed, the Bch log report can be output if the service data #4C ISDN Bitswitch SW01 bit 7 is set to "0.")
Transmission report (with service error code and dump list)	If you set bits 0 and 1 of #1 SSSW SW01 in the service mode, the service error code and dump list are indicated on the activity report.
Reception report (with service error code and dump list)	If you set bits 0 and 1 of #1 SSSW SW01 in the service mode, the service error code and dump list are indicated on the activity report.

a-1) System data list

This list shows service data setting statuses of service soft switches and service parameters.

```

15/01 2000 17:09 FAX 001

*****
***  SYSTEM DATA LIST  ***
*****

#1  SSSW

SW01      ----      00010000
SW02      ----      00000000
SW03      ----      00000000
SW04      ----      10000000
SW05      ----      00000000
SW06      ----      10000000
SW07      ----      00000000
SW08      ----      00000000
SW09      ----      00000000
SW10      ----      00000000
SW11      ----      00000000
SW12      ----      00000010
SW13      ----      00000000
SW14      ----      00000000
SW15      ----      00000000
SW16      ----      00000011
SW17      ----      00000000
SW18      ----      00000000
SW19      ----      00000000
SW20      ----      00000000
SW21      ----      00000000
SW22      ----      00000000
SW23      ----      00000000
SW24      ----      00000000
SW25      ----      00000000
SW26      ----      00000000
SW27      ----      00000000
SW28      ----      00000000
SW29      ----      00000000
SW30      ----      00000000
SW31      ----      00000000
SW32      ----      00000000
SW33      ----      00000000
SW34      ----      00000000
SW35      ----      00000000
SW36      ----      00000000
SW37      ----      00000000
SW38      ----      00000000
SW39      ----      00000000
SW40      ----      00000000
SW41      ----      00000000
SW42      ----      00000000
SW43      ----      00000000
SW44      ----      00000000
SW45      ----      00000000
SW46      ----      00000000
SW47      ----      00000000
SW48      ----      00000000
SW49      ----      00000000
SW50      ----      00000000

#2  MENU

05:      ----      OFF
06:      ----      DIAL
07:      ----      10
08:      ----      3429
09:      ----      33.6
10:      ----      25Hz
    
```

Figure 2-10 System Data List (1/7)

15/01 2000 17:10 FAX			002
#3 NUMERIC Param.			
01:	----		0
02:	----		10
03:	----		15
04:	----		12
05:	----		4
06:	----		4
07:	----		350
08:	----		0
09:	----		6
10:	----		5500
11:	----		3500
12:	----		0
13:	----		1320
14:	----		0
15:	----		120
16:	----		4
17:	----		100
18:	----		0
19:	----		400
20:	----		100
21:	----		0
22:	----		400
23:	----		4
24:	----		10
25:	----		60
26:	----		4
27:	----		0
28:	----		0
29:	----		0
30:	----		0
#4A SPECIAL			
SW01	----		00001000
SW02	----		10000100
SW03	----		00000000
SW04	----		00000100
SW05	----		00000000
SW06	----		00000000
SW07	----		01000000
SW08	----		01000000
SW09	----		00000000
SW10	----		00000000
SW11	----		00000000
SW12	----		00000000
SW13	----		00000000
SW14	----		00000000
SW15	----		00000000
SW16	----		00110011
SW17	----		00010000
SW18	----		00000000
SW19	----		00000000
SW20	----		00000000
SW21	----		00000000
SW22	----		00000000
SW23	----		00000000
SW24	----		00000010
SW25	----		00010101
SW26	----		00000000
SW27	----		00000000
SW28	----		00000001
SW29	----		00000010
SW30	----		00000000

Figure 2-11 System Data List (2/7)

15/01 2000 17:10 FAX		003
01 :	----	5
02 :	----	30
03 :	----	30
04 :	----	4
05 :	----	150
06 :	----	100
07 :	----	6
08 :	----	0
09 :	----	0
10 :	----	10
11 :	----	1
12 :	----	7
13 :	----	9
14 :	----	60
15 :	----	6000
16 :	----	8
17 :	----	60
18 :	----	99
19 :	----	0
20 :	----	58
21 :	----	0
22 :	----	0
23 :	----	99
24 :	----	10
25 :	----	25
26 :	----	2
27 :	----	2
28 :	----	0
29 :	----	0
30 :	----	6
31 :	----	0
32 :	----	0
33 :	----	0
34 :	----	0
35 :	----	0
36 :	----	0
37 :	----	0
38 :	----	0
39 :	----	0
40 :	----	0
41 :	----	0
42 :	----	0
43 :	----	0
44 :	----	0
45 :	----	0
46 :	----	0
47 :	----	0
48 :	----	0
49 :	----	0
50 :	----	0
51 :	----	0
52 :	----	0
53 :	----	0
54 :	----	0
55 :	----	0
56 :	----	0
57 :	----	0
58 :	----	0
59 :	----	0
60 :	----	0
61 :	----	0
62 :	----	0
63 :	----	0
64 :	----	0
65 :	----	0

Figure 2-12 System Data List (3/7)

15/01 2000 17:10 FAX			004
66 :	----	0	
67 :	----	0	
68 :	----	0	
69 :	----	0	
70 :	----	0	
#4B NCU			
1.TONE / PULSE			
1.TONE			
01 :	----	100	
02 :	----	100	
2.PULSE		DP(N)	
01 :	----	100	
02 :	----	200	
03 :	----	40	
04 :	----	880	
2.DIAL TONE		01000000	
01 :	----	350	
02 :	----	130	
03 :	----	10	
04 :	----	0	
05 :	----	0	
06 :	----	5	
07 :	----	3	
08 :	----	0	
3.2nd DIAL TONE		00000000	
01 :	----	200	
02 :	----	0	
03 :	----	0	
04 :	----	0	
05 :	----	0	
06 :	----	0	
07 :	----	0	
08 :	----	0	
4.BUSY TONE 0		00000000	
01 :	----	1000	
02 :	----	40	
03 :	----	60	
04 :	----	40	
05 :	----	60	
06 :	----	1	
07 :	----	3	
08 :	----	3	
5.BUSY TONE 1		00000000	
01 :	----	1000	
02 :	----	40	
03 :	----	60	
04 :	----	40	
05 :	----	60	
06 :	----	1	
07 :	----	3	
08 :	----	3	
6.REORDER TONE		10000000	
01 :	----	0	
02 :	----	35	
03 :	----	80	
04 :	----	35	
05 :	----	80	

Figure 2-13 System Data List (4/7)

15/01 2000 17:11 FAX			005
06 :	----		5
07 :	----		3
08 :	----		3
7. MULTI			
01 :	----		0
02 :	----		10
03 :	----		0
04 :	----		0
8. AUTO RX			
01 :	----		7
02 :	----		60
03 :	----		10
04 :	----		60
05 :	----		1100
06 :	----		0
07 :	----		2
08 :	----		15
09 :	----		65
9. CNG DETECT			
01 :	----		35
02 :	----		60
03 :	----		0
04 :	----		0
05 :	----		0
06 :	----		85
07 :	----		40
08 :	----		60
09 :	----		8
10 :	----		0
11 :	----		2
12 :	----		70
10. RKEY			
01 :	----		9
02 :	----		30
03 :	----		0
11. PBX DIAL TONE			00000000
01 :	----		350
02 :	----		130
03 :	----		10
04 :	----		0
05 :	----		0
06 :	----		5
07 :	----		3
08 :	----		0
12. PBX BUSY TONE			00000000
01 :	----		1000
02 :	----		40
03 :	----		60
04 :	----		40
05 :	----		60
06 :	----		1
07 :	----		3
08 :	----		3
#5 TYPE			
TYPE	----		EUROPE

Figure 2-14 System Data List (5/7)

15/01 2000 17:11 FAX			006
#7	PRINTER		
	SW01	-----	00000000
	SW02	-----	00000000
	SW03	-----	00000000
	SW04	-----	00000000
	SW05	-----	00000000
	SW06	-----	00000100
	SW07	-----	00000000
	SW08	-----	00000000
	SW09	-----	00000000
	SW10	-----	00000000
	SW11	-----	00000000
	SW12	-----	00000000
	SW13	-----	00000000
	SW14	-----	00000000
	SW15	-----	00000000
	SW16	-----	00000000
	SW17	-----	00000000
	SW18	-----	00000000
	SW19	-----	00000000
	SW20	-----	00000000
	01 :	-----	15
	02 :	-----	0
	03 :	-----	0
	04 :	-----	2
	05 :	-----	7
	06 :	-----	0
	07 :	-----	0
	08 :	-----	0
	09 :	-----	0
	10 :	-----	0
	11 :	-----	0
	12 :	-----	0
	13 :	-----	0
	14 :	-----	0
	15 :	-----	0
	16 :	-----	0
	17 :	-----	0
	18 :	-----	0
	19 :	-----	0
	20 :	-----	0
	21 :	-----	0
	22 :	-----	0
	23 :	-----	0
	24 :	-----	0
	25 :	-----	0
	26 :	-----	0
	27 :	-----	0
	28 :	-----	0
	29 :	-----	0
	30 :	-----	0
#9	ROM		
	VERSION		EC-02-01

Figure 2-15 System Data List (6/7)

15/01 2000 17:11 FAX			007
START DATE			
DATE	-----	15/01	'00

Figure 2-16 System Data List (7/7)



NOTE

“START DATE” records the date when this fax performs its first transmission or reception, after shipment from the factory.

- *1 : Date on which data was initialized with service data #8 CLEAR, ALL
- *2 : Total number of transmission
- *3 : Total number of pages transmitted for each document size
- *4 : Total number of reception
- *5 : Total number of pages received for each document size
- *6 : Total number of pages transmitted and received for each modem speed
- *7 : Total number of pages transmitted and received for each mode
- *8 : Total number of pages transmitted and received for each coding method
- *9 : Total number of pages transmitted and received in each mode
- *10: Total number of pages printed/scanned

[Display example]

PRINT = 30*/100** READ = 30*/100**

* Indicates the value input with Service Data #8 CLEAR, COUNTER.

** Indicates the value counted since shipment from the factory.

- *11: Total number of occurrences for each error code

[Display example]

# #280	1	7	3	0	0
	##0280	##0281	##0282		
	errors	errors	errors		

Displays error information for the 3 most recent communications.

```

15/01/2000 13:06 FAX 1234567890          Canon          ☐002
#1 LATEST                               * 1 ##0106

* 2 START TIME                           06/01 08:58
* 3 OTHER PARTY                           5689
* 4 MAKER CODE                             10001000
* 5 MACHINE CODE                           11001010 00000000
* 6 RCV V.8 FRAME                           E0 81 85 D4 90 7E 00 00
* 7 SYMBOL RATE                             3429
* 8 DATA RATE                              21.6
* 9 TX LVL REDUCTION                         0
*10 ERR ABCODE                              92
*11 ERR SECTXB                              80
*12 ERR SECRXB                              80

*13 Rx : (bit 1) 00000000 01000000 00011111 00100001 00000001 00000001 00000001 (bit56)
          (bit57) 00000001 00000001 00000100 00000000 00000000 (bit96)
*14 Tx : (bit 1) 00000100 01110011 00010001 00100011 00000001 10101001 00000001 (bit56)
          (bit57) 00000001 00000001 00010100 00000000 00000000 (bit96)

*15
Rx :      NSS TSI DCS   PPS-EOP   PPS-EOP
Tx : NSF DIS          CFR       PPR       PPR
    
```

Figure 2-18 System Dump List (2/2)

- *1 : Service error code
- *2 : Communication start date and time (on 24-hour display)
- *3 : Telephone number sent from other party
- *4 : Maker code
- *5 : Machine code
- *6 : Received V.8 protocol signal
- *7 : Symbol rate used for the primary channel
- *8 : Transmission speed used for the primary channel
- *9 : 0 (Fixed)
- *10: Code output by the modem when an error occurred
(Not used in the field)
- *11: Transmit status of the modem when an error occurred
(Not used in the field)
- *12: Receive status of the modem when an error occurred
(Not used in the field)
- *13: Bit 1 to bit 96 of received DIS, DCS, or DTC
- *14: Bit 1 to bit 96 of transmitted DIS, DCS, or DTC
- *15: RX=Received protocol signal
TX=Transmitted protocol signal



NOTE

When an error occurs in direct transmission, *6 to *12 will not be listed even if the other party's machine has a V.34 modem.

a-3) Service activity report

The ERROR TX REPORT includes appended service error codes and an error dump list. In user data “REPORT SETTINGS”, when the “REPORT WITH TX IMAGE” is set to “ON” in the “TX REPORT”, a section of the first page of transmitted image data is appended when memory transmission is done.

```

15/01/2000 13:11 FAX 1234567890          Canon          001
*****
***  ERROR TX REPORT  ***
*****

*1TX FUNCTION WAS NOT COMPLETED

*2TX/RX NO           0298
*3CONNECTION TEL           01
*4CONNECTION ID
*5ST. TIME
*6USAGE T           00'43
*7PGS. SENT           0
*8RESULT           NG          ##0765

*9 START TIME           15/01 13:11
*10 OTHER PARTY           01
*11 MAKER CODE           10001000
*12 MACHINE CODE           11001010 00000000
*13 RCV V.8 FRAME           E0 81 85 D4 90 7E 00 00
*14 SYMBOL RATE           3429
*15 DATA RATE           33.6
*16 TX LVL. REDUCTION           0
*17 ERR ABCODE           92
*18 ERR SECTXB           8A
*19 ERR SECRXB           80

*20 Rx : (bit 1) 00000100 01110111 00010101 00100011 00000001 10101011 11000001 (bit56)
          (bit57) 00000001 00000001 00010100 00000000 00000000 (bit96)
*21 Tx : (bit 1) 00000000 01000000 00011111 00100001 00000001 00000001 00000001 (bit56)
          (bit57) 00000001 00000001 00000100 00000000 00000000 (bit96)

*22
Rx : NSF DIS           CFR
Tx :           NSS TSI DCS   PIX-336 PPS-EOP PPS-EOP PPS-EOP DCN
    
```

Figure 2-19 Service Error Activity Report



NOTE

When an error occurs with direct transmission, *6 to *12 will not be listed even if the other party's machine has a V.34 modem.

- *1 : OK, NG messages
- *2 : Indicates four digits of the transaction number
- *3 : Number sent from the other party or number dialed (lower 20 digits)
- *4 : ID sent from the other party, if the other party is a Canon fax
- *5 : Communication start date and time (on 24-hour display)
- *6 : Communication time (in minutes and seconds)
- *7 : Number of pages for which transmission was complete
- *8 : "NG" display with number of pages for which transmission was fault, and service error code
- *9 : Communication start date and time (on 24-hour display)
- *10: Telephone number sent from other party
- *11: Maker code
- *12: Machine code
- *13: Received V.8 protocol signal
- *14: Symbol rate used for the primary channel
- *15: Transmission speed used for the primary channel
- *16: 0 (Fixed)
- *17: Code output by the modem when an error occurred
(Not used in the field)
- *18: Transmit status of the modem when an error occurred
(Not used in the field)
- *19: Receive status of the modem when an error occurred
(Not used in the field)
- *20: Bit 1 to bit 96 of received DIS, DCS, or DTC
- *21: Bit 1 to bit 96 of transmitted DIS, DCS, or DTC
- *22: RX=Received protocol signal
TX=Transmitted protocol signal

3.2 User Data Flowchart

Press the Data registration to access User menu. Figures in boldface indicate the default setting.

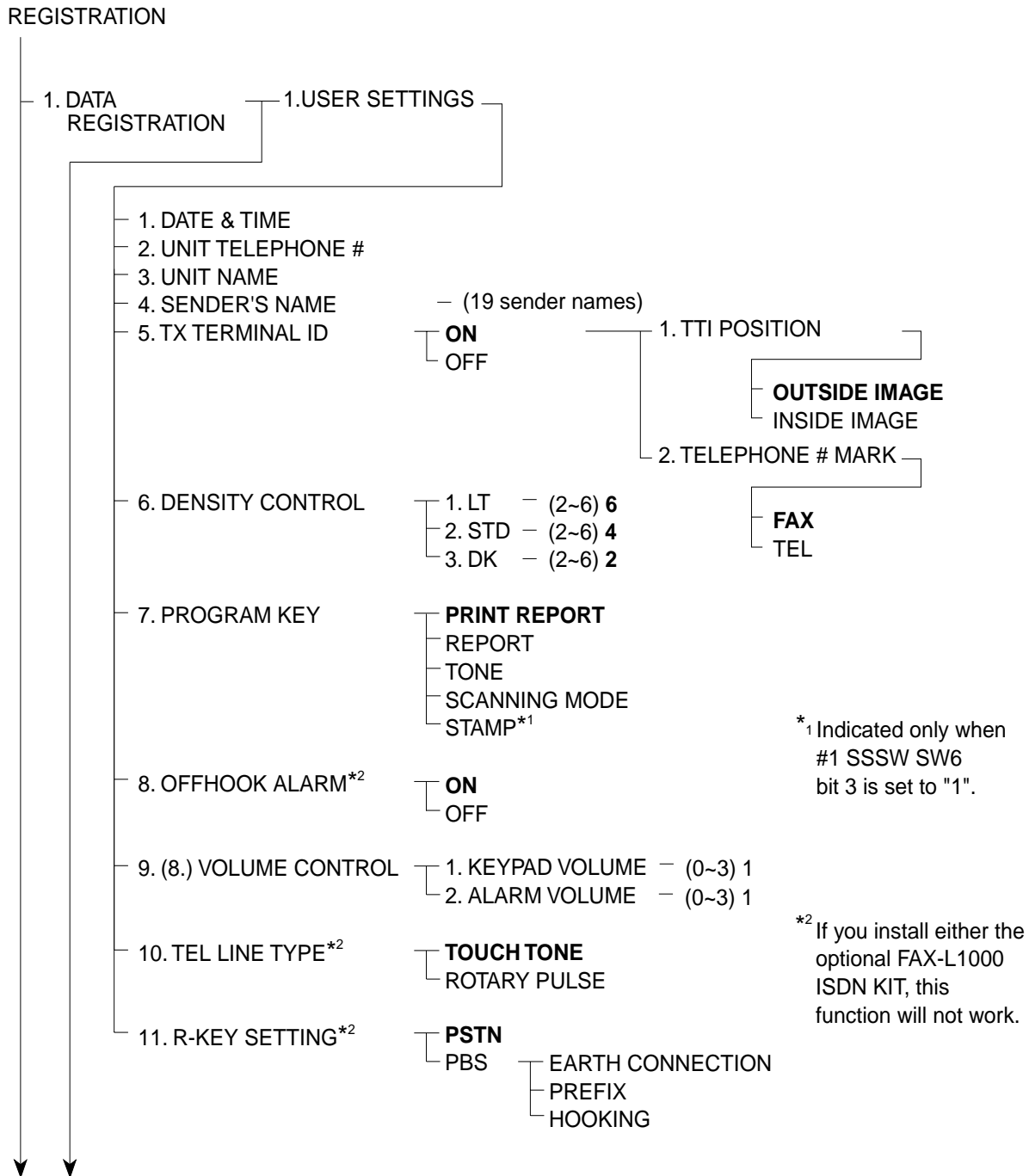

*¹ Indicated only when #1 SSSW SW6 bit 3 is set to "1".

*² If you install either the optional FAX-L1000 ISDN KIT, this function will not work.

Figure 2-20 User Menu Settings (1/13)

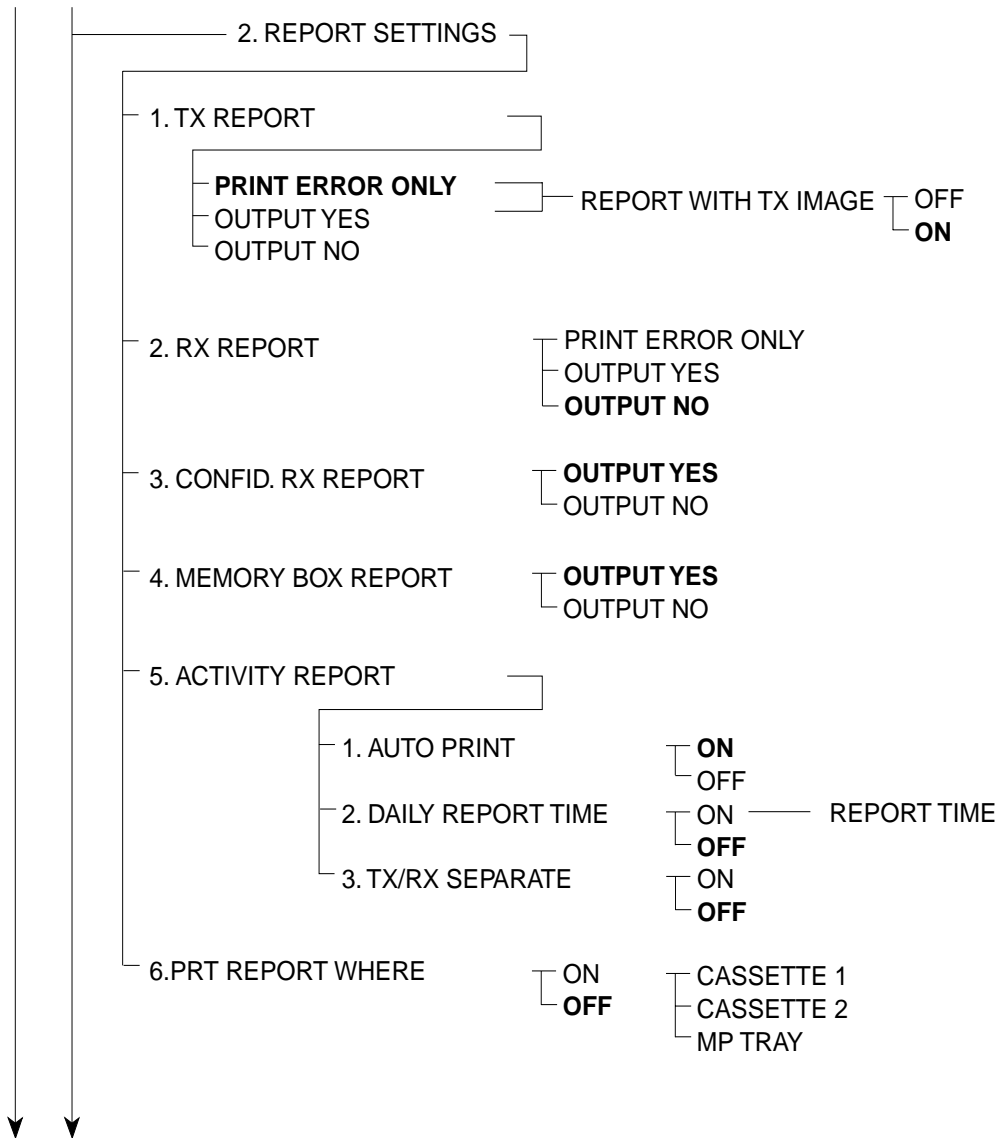

Figure 2-21 User Menu Settings (2/13)

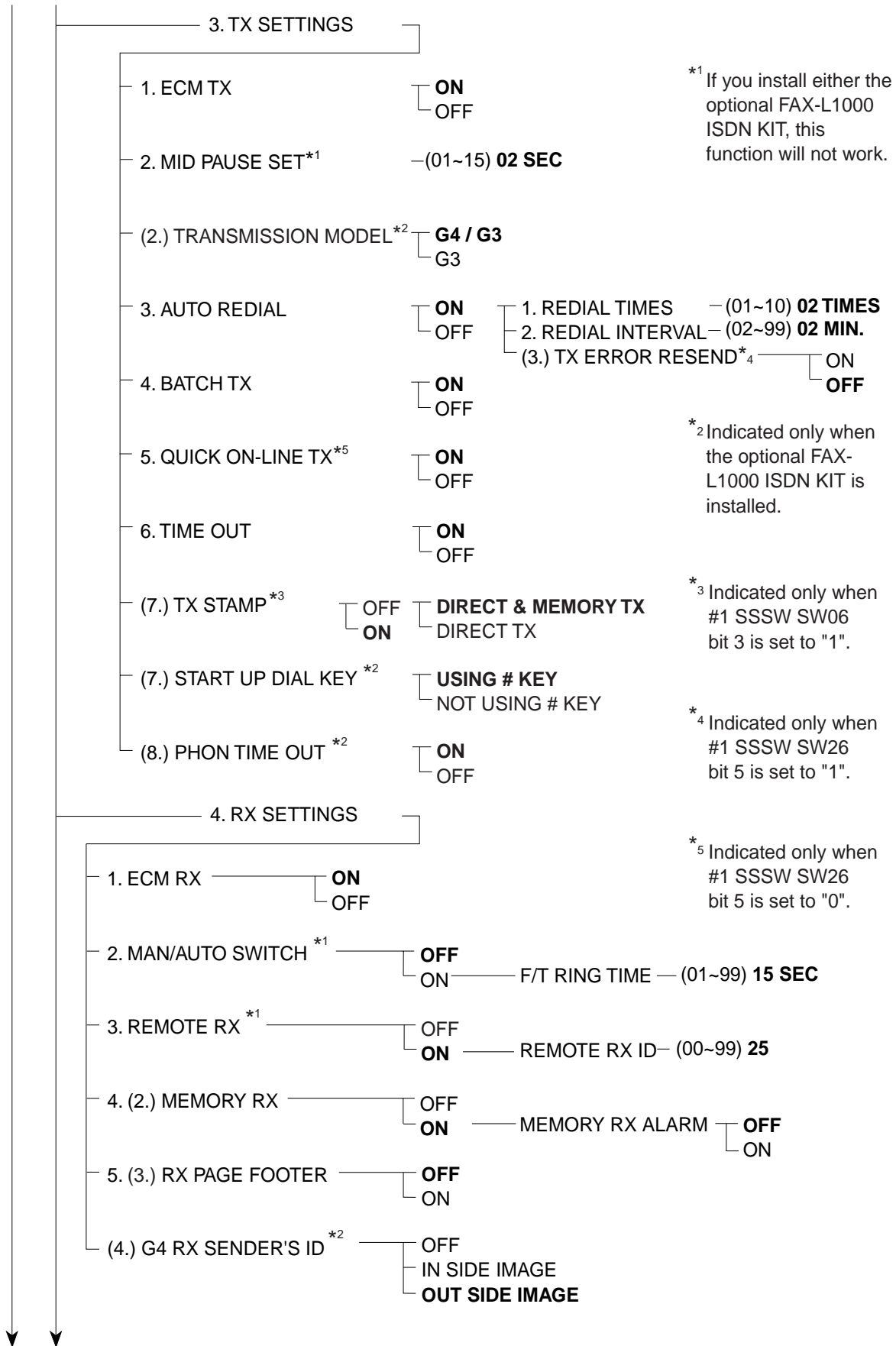

Figure 2-22 User Menu Settings (3/13)

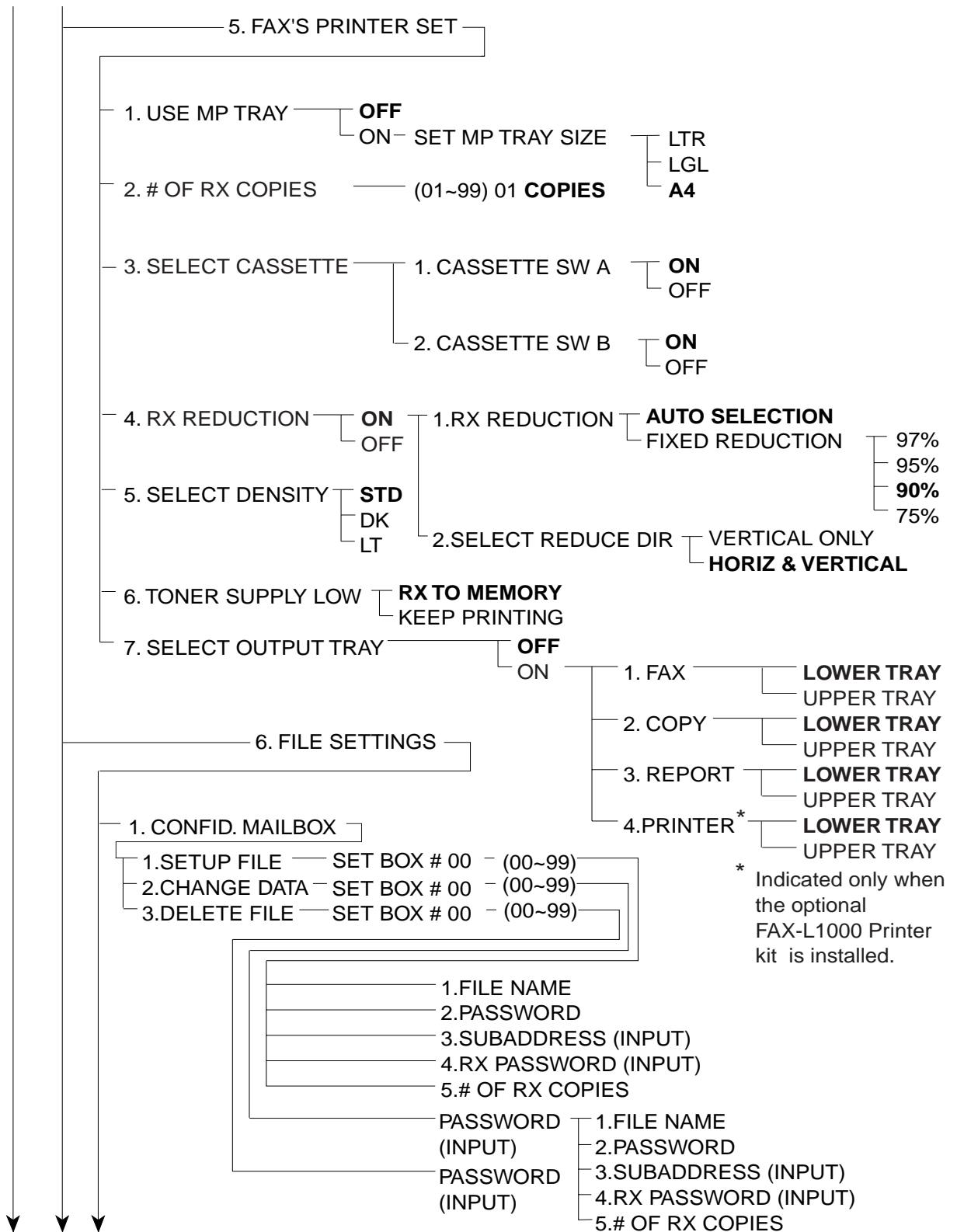

Figure 2-23 User Menu Settings (4/13)



Figure 2-24 User Menu Settings (5/13)

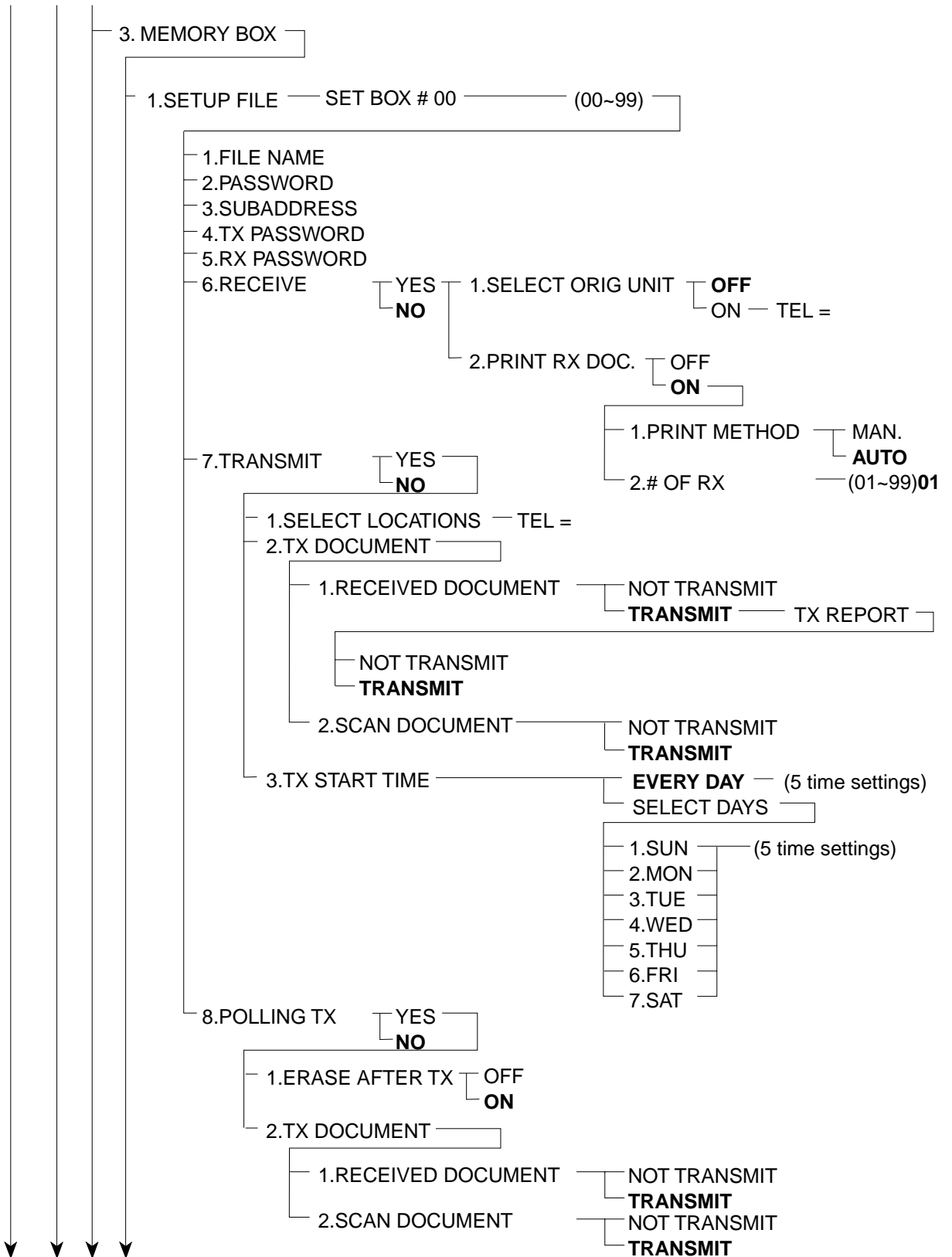

Figure 2-25 User Menu Settings (6/13)

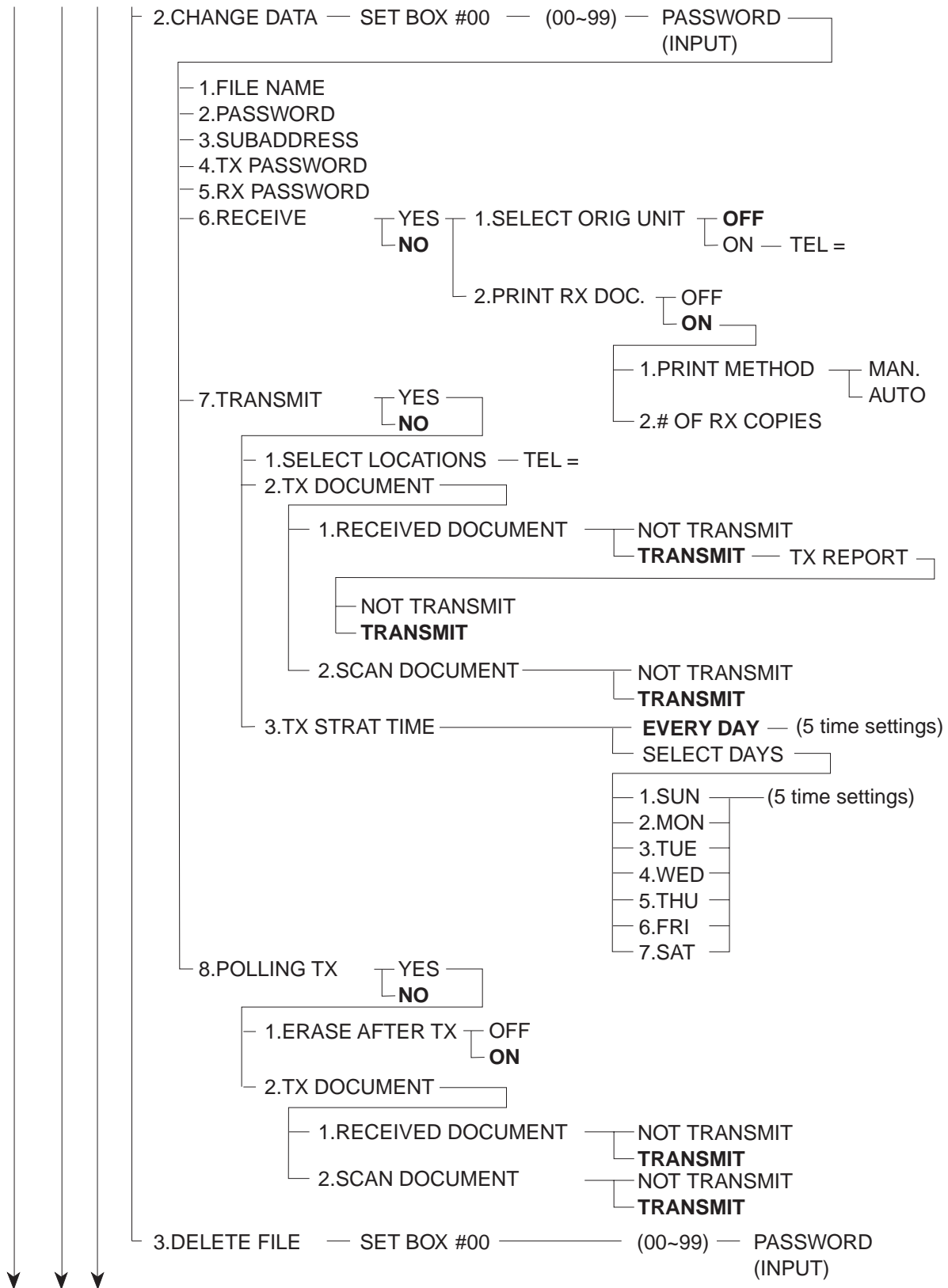

Figure 2-26 User Menu Settings (7/13)

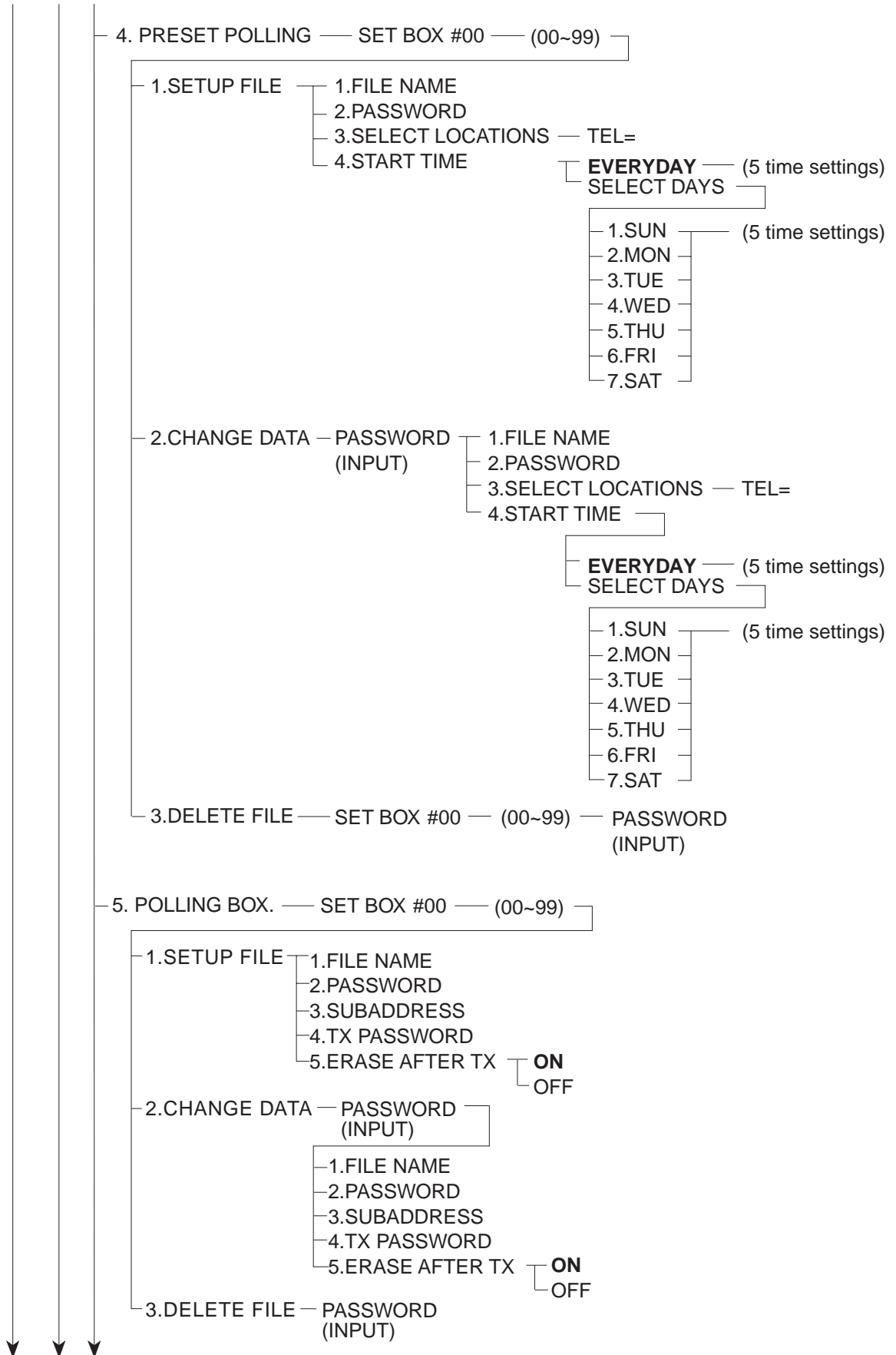

Figure 2-27 User Menu Settings (8/13)

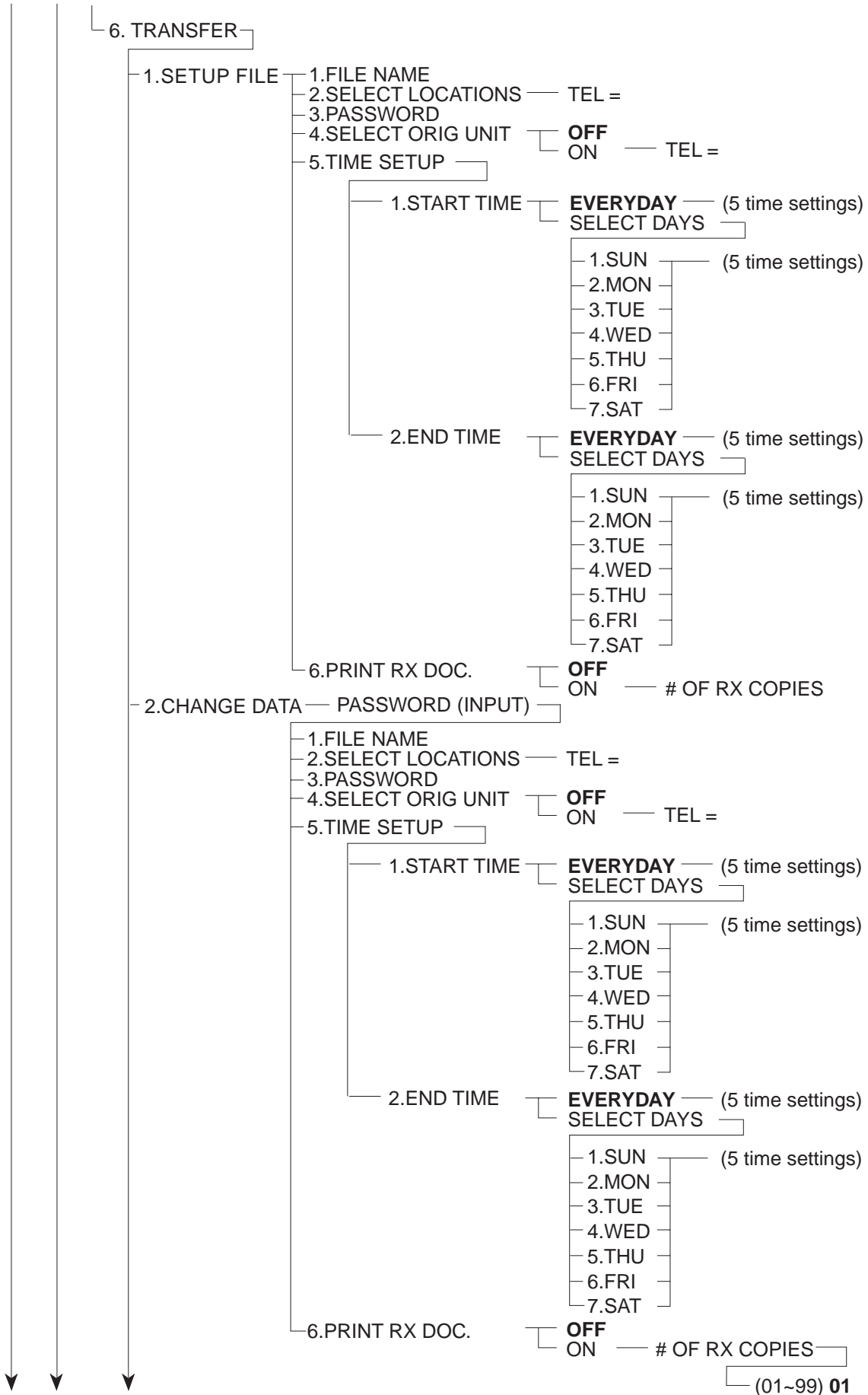

Figure 2-28 User Menu Settings (9/13)

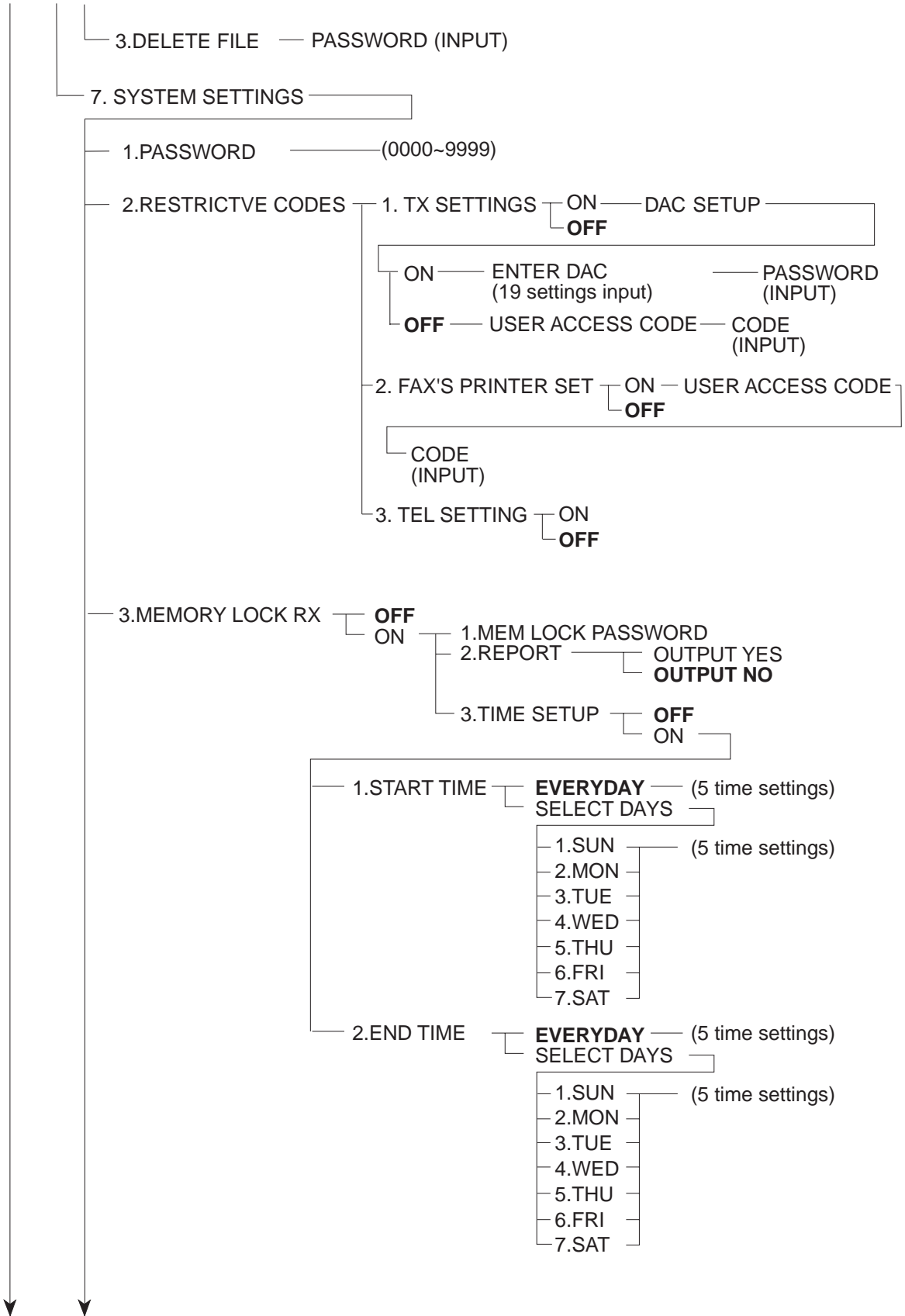

Figure 2-29 User Menu Settings (10/13)

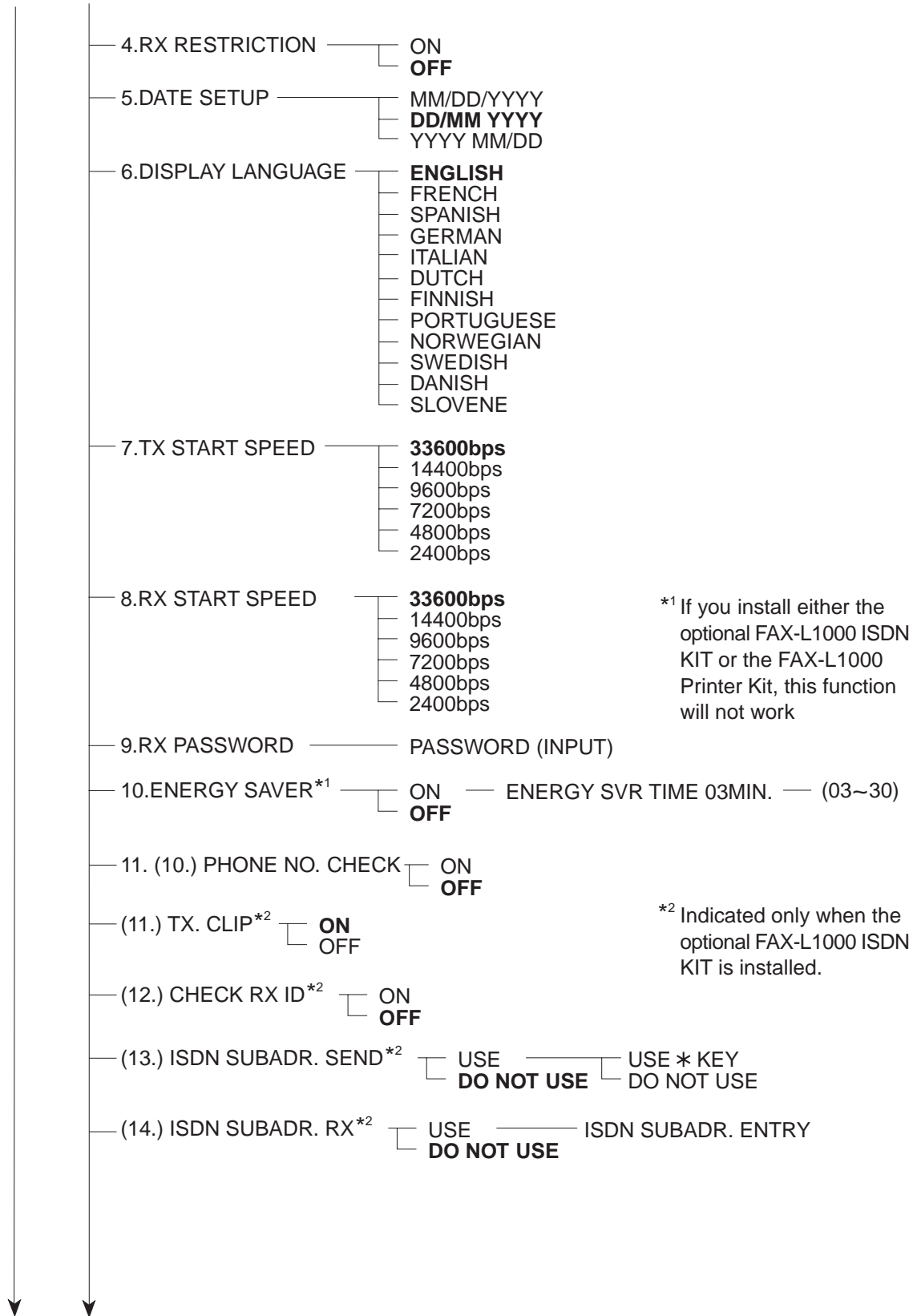

Figure 2-30 User Menu Settings (11/13)

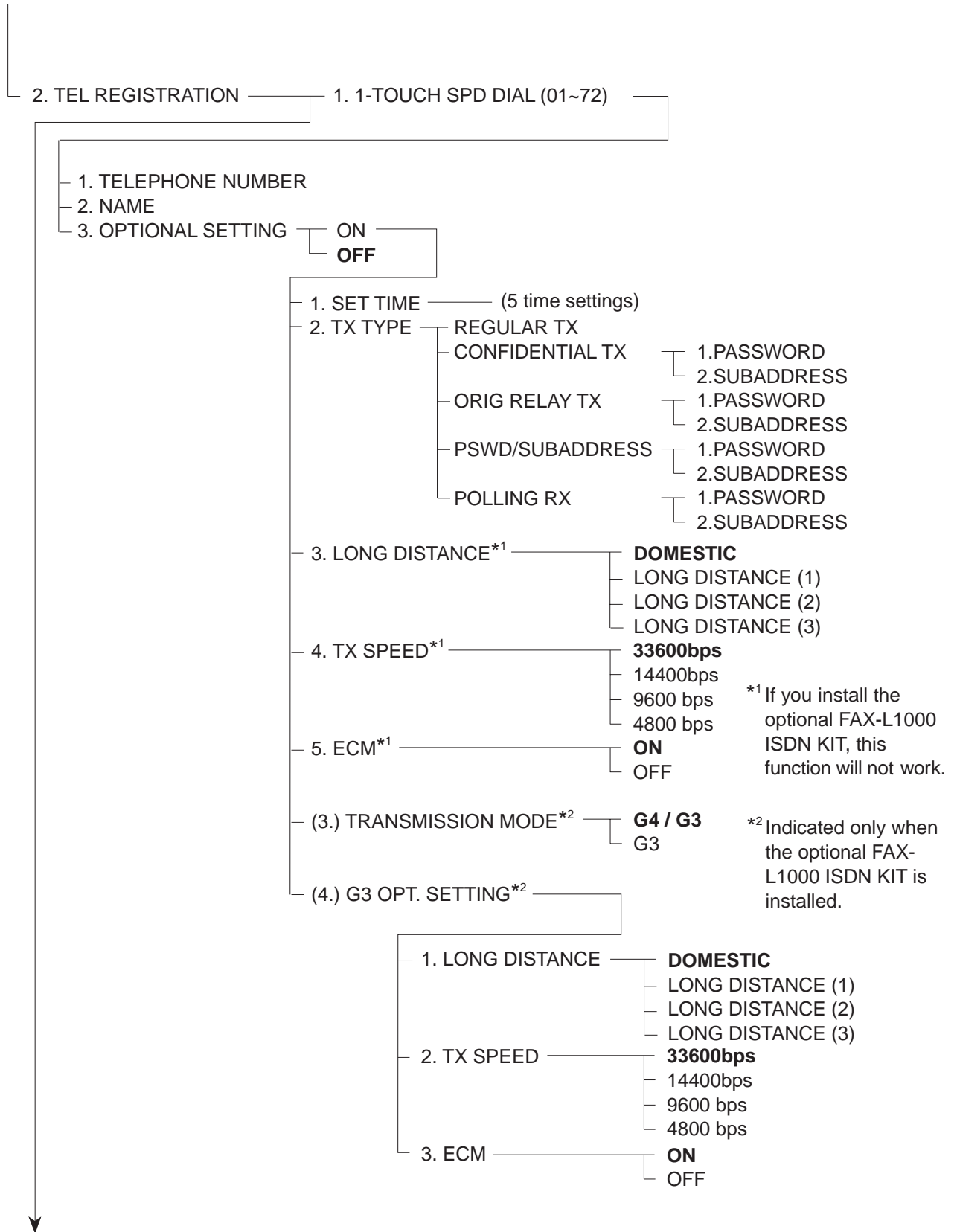

Figure 2-31 User Menu Settings (12/13)

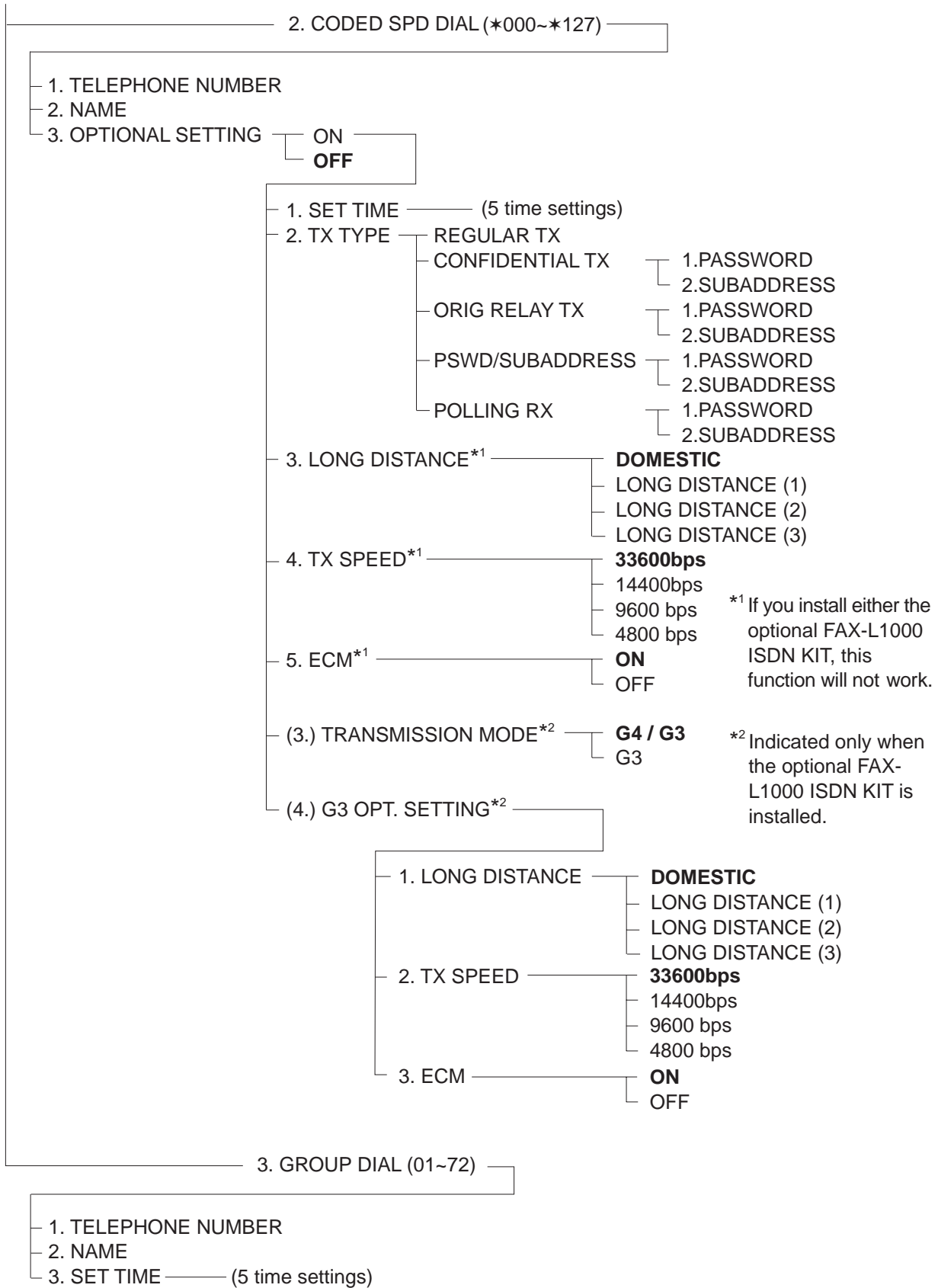

Figure 2-32 User Menu Settings (13/13)

3.3 Service Switches

3.3.1 Hardware switches

This fax has the following hardware switches.

a) SCNT board

Jumper switch (JP1)

The secondary vanadium-lithium battery backs up image memory by causing a short with the jumper plug.

Jumper switch (JP2)

The lithium battery backs up control memory by causing a short with the jumper plug.



REFERENCE

Refer to *Chapter 1, 3.2 Backed up by rechargeable battery and 3.3 Backed up by lithium battery* for details regarding jumper switches (JP1 and JP2).

Jumper switches (JP3, J6)

These are for factory adjustments, so please do not change these settings.

b) Power supply board

Volume (RV1, RV2)

These are for factory adjustments, so please do not change these settings.

c) ECNT board

Push switch (SW501)

This is a test print switch for adjustment of the leading edge margin.

Volume (VR501)

This is a volume for adjustment of the leading edge margin.

Volume (VR601)

This is for factory adjustment, so please do not change this setting.

d) Laser scanner unit

Volume (VR501, VR502, VR503)

These are for factory adjustments, so please do not change these settings.

e) NCU board

There are three slide switches on the NCU board.



Figure 2-33 Slide Switch Location on NCU Board

Nation	SW No.		
	1	2	3
U.K., FRN, AE, AUS, N.Z.	B	A	B
SWEDEN	A	B	A
OTHERS (in CENV territory)	A	A	A
ITALIA	A	A	B

Figure 2-34 Slide Switch Setting



NOTE

NCU Board Switch Setting

This model has only one connection terminal for extension telephone/handset. Therefore, unlike models with two connection terminals, changing the switch settings for use in Sweden is unnecessary. The machine can be used without changing switches 1 through 3.

3.3.2 Service data setting

Service data can be checked and changed with items on display menus. The effective SSSWs/parameters and their default values in this fax machine are shown in *3.3.4 Service data flowchart* in this chapter. Detailed description of each SSSW/parameter is not given in this manual except the new SSSWs/parameters added to this model. See *G3 Facsimile SERVICE DATA HANDBOOK (Rev. 0) (supplied separately)* for details of them. The new switches for this model are described in *3.3.6 New SSSWs/parameters added to this model*.

#1 SSSW (Service Soft Switch Settings)

These setting items are for basic fax service functions such as error management, echo countermeasures, and communication trouble countermeasures.

#2 MENU (MENU switch settings)

These setting items are for functions required during installation, such as NL equalizer and transmission levels.

#3 NUMERIC Param. (NUMERIC parameter settings)

These setting items are for inputting numeric parameters such as the various conditions for the RTN signal transmission.

#4A SPECIAL

These setting items are for telephone network control functions.

#4B NCU (NCU settings)

These setting items are for telephone network control functions such as the selection signal transmission conditions and the detection conditions, for the control signals sent from the exchange.

#4C ISDN (ISDN settings)

These settings items are for the purpose of controlling the D-channel protocol and the B-channel protocol.

#5 TYPE (TYPE setting)

The type setting makes the service data conform to a specific country communications standards.

#6 GENESIS (UHQ function setting)

These setting items are for scanned image processing such as edge enhancement and error diffusion processing.

#7 PRINTER (PRINTER function settings)

These setting items are for basic printer service functions such as the reception picture reduction conditions. Also there is an item for resetting the printer section without switching the power off-on.

#8 CLEAR (data initialization mode)

Various data are initialized by selecting one of these setting items. There is a setting item for checking/inputting the total number of pages printed and total number of pages scanned by this fax.

#9 ROM (ROM management)

ROM data such as the version number and checksum are displayed.

3.3.3 Service data registration/setting method

Service data can be registered/set by the following operations:

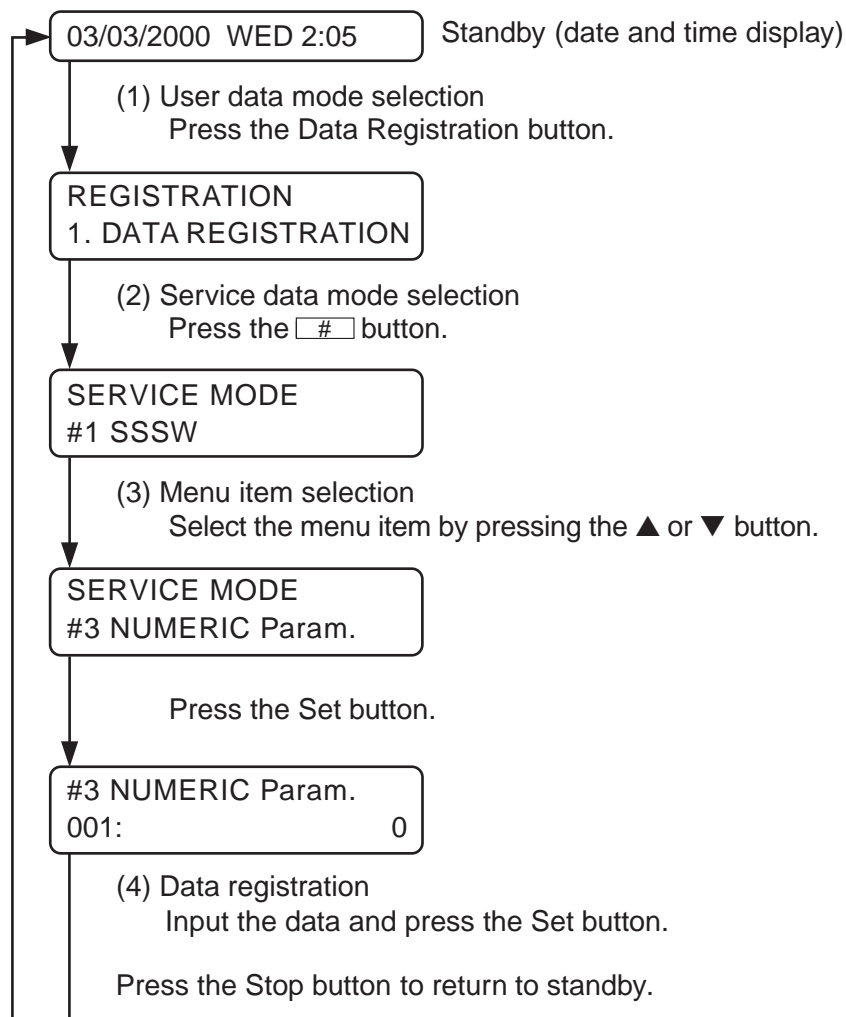

Figure 2-35 Service Data Setting Method

3.3.4 Service data flowchart

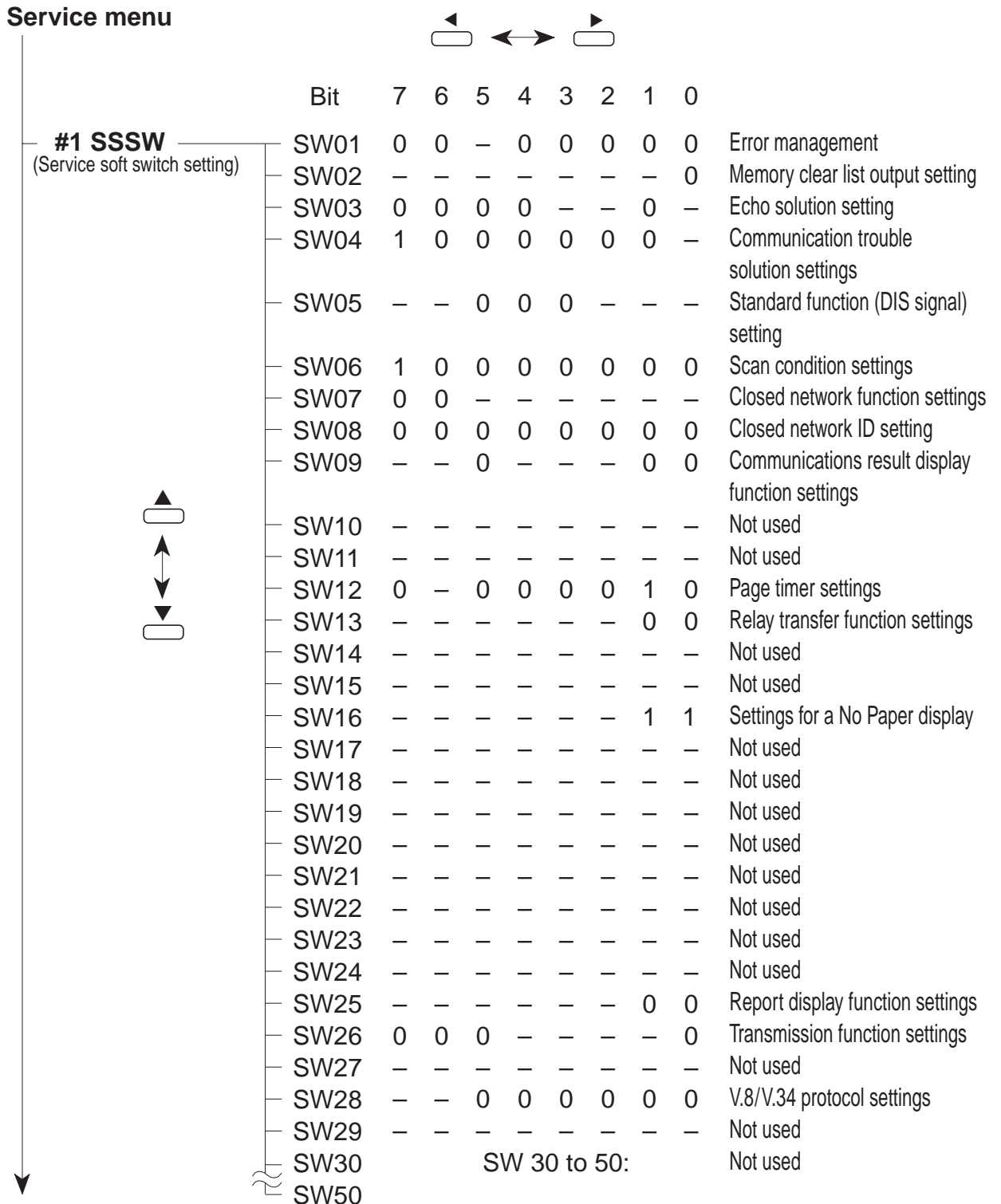

Figure 2-36 Service Data (1/6)



The switches marked “-” are not used. Do not change their settings.

#2 MENU (Menu switch settings)	001:		Not used
	002:		Not used
	003:		Not used
	004:		Not used
	005:	ON OFF	NL equalizer setting
	006:	DIAL SERVICEMAN OFF	Line monitor setting
	007:	10 (-10dBm)	Transmission level (8~15)
	008:	3429 baud 3200 baud 3000 baud 2800 baud 2743 baud 2400 baud	V.34 Baud rate setting
	009:	33.6 kbps (2.4 × n : 1 ≤ n ≤ 14)	V.34 Transmission speed
	010 :	25Hz 17Hz 50Hz	Frequency of psudo CI
	011:	Items 011 to 020:	Not used
	020:		

Figures in boldface indicate the default setting.

Figure 2-37 Service Data (2/6)



No. 001 to 004, 011 to 020 are not used. Do not change their settings.

#3 NUMERIC Param. (Numeric parameter settings)			
	Default	Rang	
001:	0		Not used
002:	10 (10%)	(1~99)	RTN signal transmission condition (1)
003:	15 (15 times)	(2~99)	RTN signal transmission condition (2)
004:	12 (12 lines)	(1~99)	RTN signal transmission condition (3)
005:	4		Not used
006:	4		Not used
007:	350		Not used
008:	0		Not used
009:	6 (6 digits)	(1~20)	The number of digits in telephone number compared against TSI signal to be matched for restricted receiving function
010:	5500 (55 seconds)	(0~9999)	T0 Timer
011:	3500 (35 seconds)	(0~9999)	T1 Timer (Rx)
012:	0		Not used
013:	1300 (13.0 seconds)	(500~3000)	Maximum time allowed to receive one line of image data
014:	0		Not used
015:	120 (1200 ms)	(0~999)	Hooking detection time
016:	Items 016 to 080:		Not used
080:			

Figure 2-38 Service Data (3/6)



No. 001, 005 to 008, 012, 014, and 016 to 080 are not used. Do not change their settings

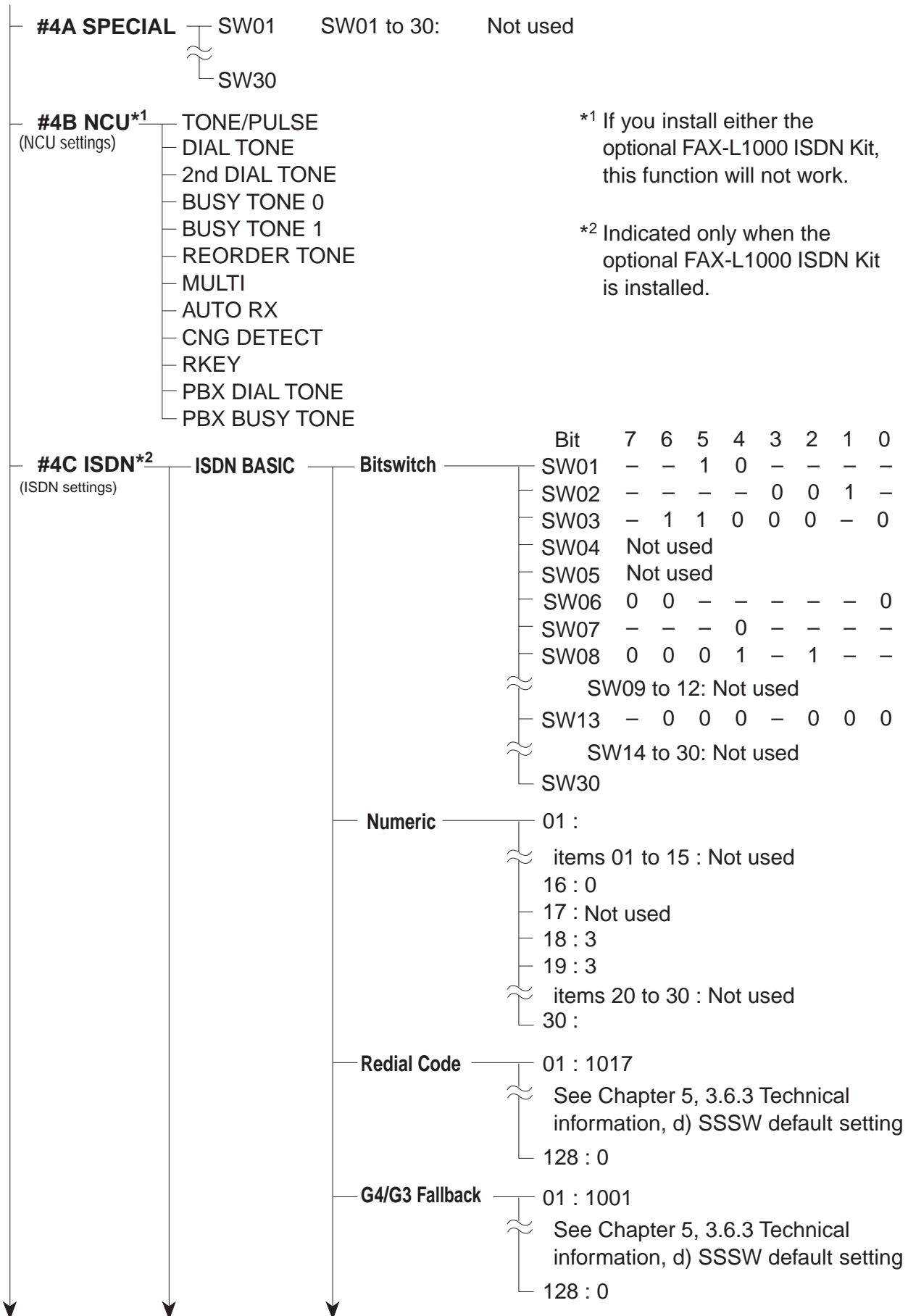

Figure 2-39 Service Data (4/6)

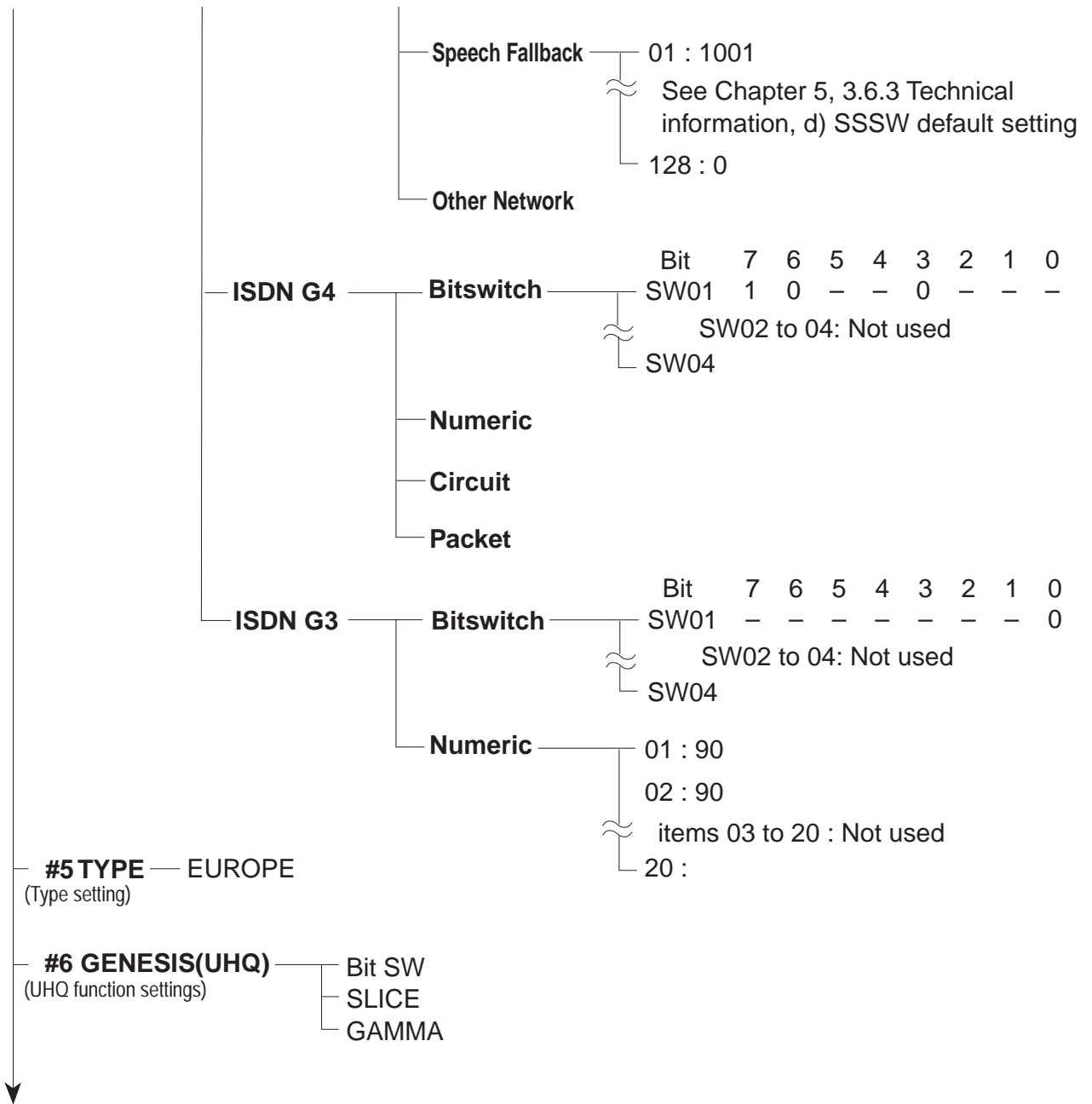

Figure 2-40 Service Data (5/6)



#4A SPECIAL, #4B NCU

The values of these items are all set to match a specific nation's communications standards by the #5 TYPE setting. Do not change these settings.

#6 GENESIS (UHQ function settings)

Tampering with this setting may cause the scanned image quality to deteriorate.

Do not change these settings.

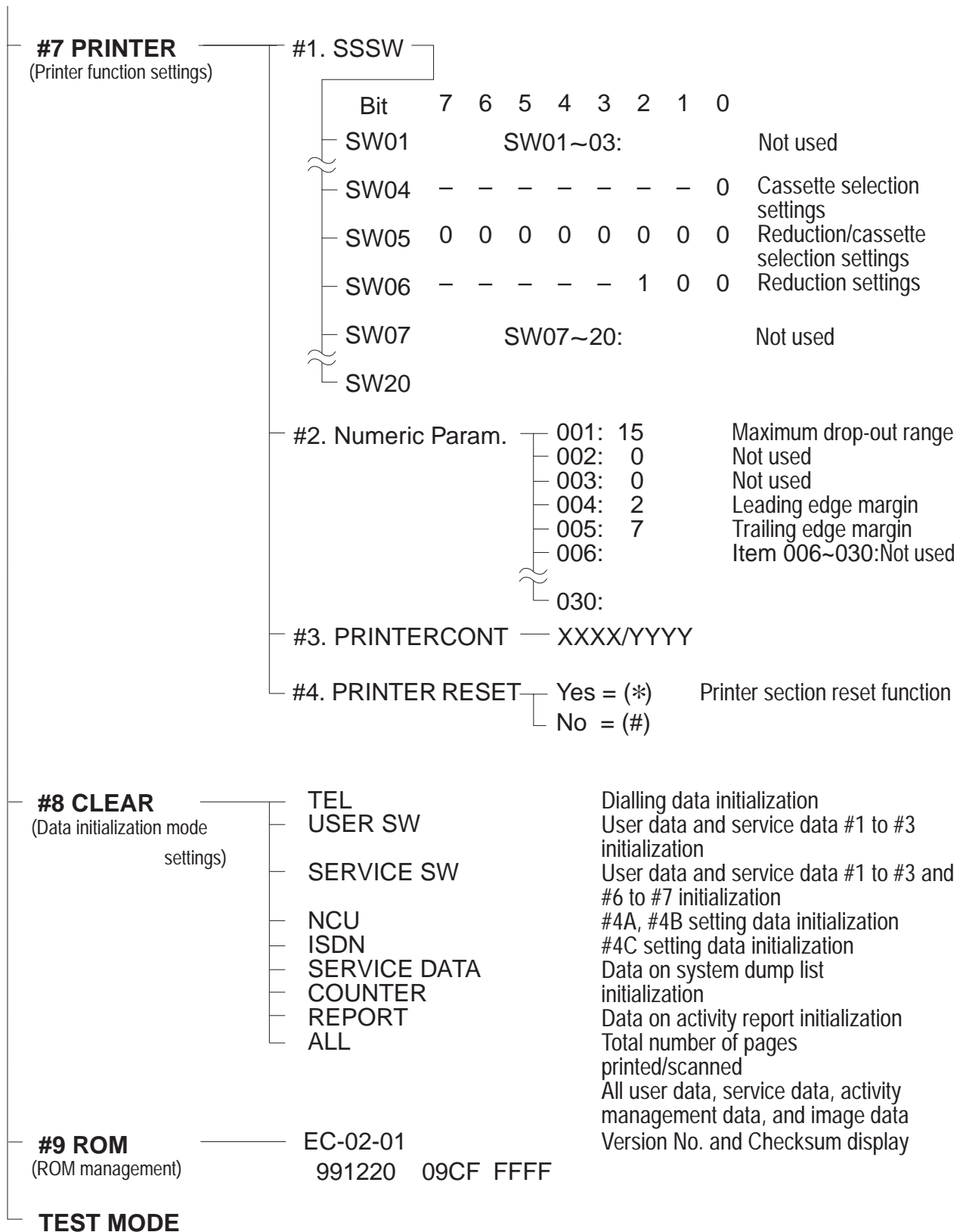

Figure 2-41 Service Data (6/6)



REFERENCE

For details on test mode, see *this Chapter, 3.4 Test Functions.*

3.3.5 Explanation of SSSW (Service Soft Switch Settings)

The items registered and set by each of these switches comprise 8-bit switches. The figure below shows which numbers are assigned to which bits. Each bit has a value of either 0 or 1.

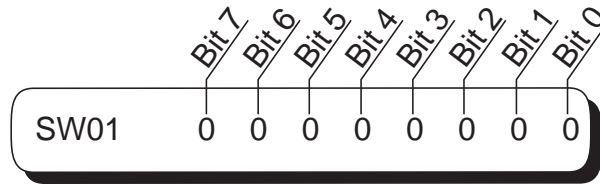

Figure 2-42 Bit Switch Display

See the chart in the service menu shown in Section 3.3.4 Service data flowchart to see effective bits and their default values. The meanings (functions) of the bits are not described in this manual except the new switches added to this model. See *G3 Facsimile SERVICE DATA HANDBOOK (Rev. 0) (supplied separately)* for details of the switches.

Below are examples showing how to read bit switch tables.

Bit	Function	1	0
0	Service error code	Output	Not Output
1	Error dump list	Output	Not Output
2	Receive image transfer	Yes	No
3	Not used		
4	Not used		
5	Not used		
6	Not used		
7	Not used		

Callouts:
 - "Indicates that the setting is '1'." points to the '1' column.
 - "Indicates that the setting is '0'." points to the '0' column.
 - "Figures in boldface are default settings." points to the bolded values in the '0' column.

Figure 2-43 How to Read Bit Switch Tables



Do not change the settings of switches listed as "Not used".

3.3.6 New SSSWs/parameters added to this model

#1 SSSW

SW01 (service soft switch 01: error management)

Bit	Function	1	0
0	Service error code	Output	Not output
1	Error dump list	Output	Not output
2	Enter password at confidential Rx image data transfer	No	Yes
3	Copy function	No	Yes
4 (New)	##300 series service error code	Output	Not output
5	Not used		
6	Date & Time setting restriction	Setting restricted	Setting possible
7	User setting restriction	Setting possible	Setting restricted

[Bit 4]

When “Output” is selected, ##300 series Service error codes are displayed and in reports.
 When “Not output” is selected, no Service error codes are displayed.

#1 SSSW

SW05 (service soft switch 05: standard function <DIS signal> settings)

Bit	Function	1	0
0	Not used		
1	Not used		
2	Not used		
3	Send DIS signal bits 33 and over	No	Yes
4	Recording paper length availability declared in DIS signal	A4 size	Arbitrary size
5 (New)	Declare LTR/LGL in DIS signal	No	Yes
6	Not used		
7	Not used		

[Bit 5]

Select whether to declare LTR or LGL in DIS signal when the LTR or LGL recording paper is used. The recording paper is selected according to the setting of #7 printer, SW04 bit 0.

#1 SSSW

SW06 (service soft switch 06: scan condition settings)

Bit	Function	1	0
0	Document feed after DES on	No feed	Feed
1	Prescan for document scanning	No prescan	Prescan
2	Document length restriction	Not restricted	39.37" (1 m) max.
3 (New)	Stamp option	Yes	No
4	Document scan width	LETTER	A4
5	Recording paper output for long image copy	First page only	Divided onto multiple pages
6	Copy function resolution	Variable	Always fine mode
7	Superfine mode setting when AUTO key selected	Set	Not set

[Bit 3]

If a stamp unit option is installed, set this switch to 1. If it is set to 1, the Stamp Option button on the operational panel becomes effective and the “TX STAMP” setting menu appears as user’s data.

#1 SSSW

SW26 (service soft switch 26: transmission function settings)

Bit	Function	1	0
0	Compulsory direct transmission function	Set	Not set
1	Not used		
2	Not used		
3	Not used		
4	Not used		
5 (New)	Transmission error redial function	Yes	No
6	When STOP key is pressed during a sequential broadcasting	Only cancel communication in progress	Cancel all communication
7	Error transmission report when transmission is stopped	Not output	output

[Bit 5]

It can select whether transmission error redial function is effective.

When "Yes" is selected, transmission error redial setting function is displayed in transmission setting item in user menu settings and it is possible to set and activate this function. However, quick memory transmission function and memory overflow transmission function are invalid. The quick memory transmission function itself is not displayed as setting item.

When "No" is selected, transmission error redial setting function is not displayed in the transmission setting item in user menu settings and it is impossible to set and activate this function. Though, quick memory transmission function and memory overflow transmission function are valid.

Function \ Bit5	1	0
Transmission error redial	Setting: possible Operation: possible	Setting: impossible Operation: impossible
Quick memory transmission	Setting: impossible Operation: impossible	Setting: possible Operation: possible
Memory overflow transmission	Operation: impossible	Operation: possible

#1 SSSW

SW28 (service soft switch 28: V.8/V.34 protocol settings)

Bit	Function	1	0
0 (New)	Caller V.8 protocol	NO	YES
1 (New)	Called party V.8 protocol	NO	YES
2 (New)	Caller V.8 protocol late start	NO	YES
3 (New)	Called party V.8 protocol late start	NO	YES
4 (New)	V.34 reception fallback	Prohibited	Not prohibited
5 (New)	V.34 transmission fallback	Prohibited	Not prohibited
6	Not used		
7	Not used		

[Bit 0]

Select whether to use the V.8 protocol when calling. If NO is selected, the V.8 protocol is inhibited at calling and the V.21 protocol is used.

[Bit 1]

Select whether to use the V.8 protocol when called. If NO is selected, the V.8 protocol is inhibited when called and the V.21 protocol is used.

[Bit 2]

If ANSam signal is not received during transmission, select whether to use the V.8 protocol when the other fax machine declares the V.8 protocol in DIS signal. If NO is selected, the CI signal is not transmitted and the V.8 protocol is not used even if the DIS that specifies the V.8 protocol is received.

[Bit 3]

Select whether to declare the V.8 protocol in DIS signal for reception. If NO is selected, the V.8 protocol cannot be used because it is not declared in DIS signal.

[Bit 4]

Select whether the reception side falls back during V.34 reception. If Prohibited is selected, the reception side does not fall back.

[Bit 5]

Select whether the transmission side falls back during V.34 transmission. If Prohibited is selected, the transmission side does not fall back.

#2 MENU

No.	Function	Selection range	Default setting
008	V.34 max. baud rate	2400~3429	3429 (3429 baud)
009	V.34 max. transmission speed	2.4~33.6	33.6 (33600 bps)

[No. 008]

Select the maximum baud rate for V.34 transmission: 3429, 3200, 3000, 2800, 2743, and 2400.



This model cannot use 2743 baud due to its modem specification. If it is set to 2743 baud, the maximum baud rate is 2400 baud.

NOTE

[No.009]

Select the maximum transmission speed for V.34 transmission: 2.4 to 33.6 kbps ($2.4 \times n$: $1 \leq n \leq 14$).

#3 NUMERIC PARAM. (numeric parameter settings)

No.	Function	Selection range	Default setting
010	T0 Timer	0~9999	5500 (55 second)
011	T1 Timer (Rx)	0~9999	3500 (35 second)
013	Maximum time to receive one line of image data	500~3000	1320 (13.2 second)

[No.010]

The “wait time after transmission of a dialing signal ends until a significant signal is detected in transmission” was set as T1 timer with parameter 10. However, ITU-T recommends that it should be set as T0 timer, so parameter 10 has been renamed to T0 timer and the default time-out time has been changed from 35 to 55 seconds.

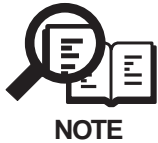

The T1 timer for the transmitter (wait time after a CED, V21 flag, or ANSam significant signal is detected until the next significant signal is detected) is fixed at 35 seconds.

[No.011]

Set the T1 timer for the receiver (wait time after DIS transmission starts until a significant signal is received).

If frequent errors occur during reception because of line connection conditions, raise the value of this parameter.

[No.013]

Set the maximum time to receive one line of image data when image data is received.

If the other party is a computer fax and the time to receive one line of image data is long, raise the value of this parameter to increase the maximum reception time.

#7 PRINTER

Service soft switch settings

SW04 (switch 04: reduction/cassette selection settings)

Bit	Function	1	0
0 (New)	When LTR/LGL specification is received by DCS, the cassette is selected according to the specification.	No	Yes
1	Not used		
2	Not used		
3	Not used		
4	Not used		
5	Not used		
6	Not used		
7	Not used		

[Bit 0]

Selects whether or not the recording paper is selected according to the DCS specification when the other fax machine specifies LTR or LGL in DCS signal during reception. If it is 0, the specified recording paper is used regardless of the paper length. If it is 1, the receiving station selects the recording paper. This switch is valid when #1 SSSW, SW05 bit 5 is 0.

SSSW Default Setting

TYPE	EUROPE	U.K.	SWEDEN	SWISS	AUSTRIA	DENMARK
#1 SSSW						
SW01	00010000	00010000	00010000	00010000	00010000	00010000
SW02	00000000	00000000	00000000	00000000	00000000	00000000
SW03	00000000	00000000	00000000	00000000	00000000	00000000
SW04	10000000	10000000	10000010	10000010	10000010	10000000
SW05	00000000	00000000	00000000	00000000	00000000	00000000
SW06	10000000	10000000	10000000	10000000	10000000	10000000
SW07	00000000	00000000	00000000	00000000	00000000	00000000
SW08	00000000	00000000	00000000	00000000	00000000	00000000
SW09	00000000	00000000	00000000	00000000	00000000	00000000
SW10	00000000	00000000	00000000	00000000	00000000	00000000
SW11	00000000	00000000	00000000	00000000	00000000	00000000
SW12	00000010	00000010	00000010	00000010	00000010	00000010
SW13	00000000	00000000	00000000	00000000	00000000	00000000
SW14	00000000	00000000	00000000	00000000	00000000	00000000
SW15	00000000	00000000	00000000	00000000	00000000	00000000
SW16	00000011	00000011	00000011	00000011	00000011	00000011
SW17	00000000	00000000	00000000	00000000	00000000	00000000
SW18	00000000	00000000	00000000	00000000	00000000	00000000
SW19	00000000	00000000	00000000	00000000	00000000	00000000
SW20	00000000	00000000	00000000	00000000	00000000	00000000
SW21	00000000	00000000	00000000	00000000	00000000	00000000
SW22	00000000	00000000	00000000	00000000	00000000	00000000
SW23	00000000	00000000	00000000	00000000	00000000	00000000
SW24	00000000	00000000	00000000	00000000	00000000	00000000
SW25	00000000	00000000	00000000	00000000	00000000	00000000
SW26	00000000	00000000	00000000	00000000	00000000	00000000
SW27	00000000	00000000	00000000	00000000	00000000	00000000
SW28	00000000	00000000	00000000	00000000	00000000	00000000
SW29	00000000	00000000	00000000	00000000	00000000	00000000
SW30	00000000	00000000	00000000	00000000	00000000	00000000
#2 MENU						
05:	OFF	OFF	OFF	OFF	OFF	OFF
06:	DIAL	DIAL	DIAL	DIAL	DIAL	DIAL
07:	10	10	10	10	10	10
08:	3429	3429	3429	3429	3429	3429
09:	33.6	33.6	33.6	33.6	33.6	33.6
10:	25Hz	25Hz	25Hz	25Hz	25Hz	25Hz

SSSW Default Setting

TYPE	NORWAY	HOLLAND	BELGIUM	AUSTRALIA	FINLAND	N.Z.
#1 SSSW						
SW01	00010000	00010000	00010000	00010000	00010001	00010000
SW02	00000000	00000000	00000000	00000000	00000000	00000000
SW03	00000000	00000000	00000000	00000000	00000000	00000000
SW04	10000010	10000010	10000000	10000000	10000000	10000000
SW05	00000000	00000000	00000000	00000000	00000000	00000000
SW06	10000000	10000000	10000000	10000000	10000000	10000000
SW07	00000000	00000000	00000000	00000000	00000000	00000000
SW08	00000000	00000000	00000000	00000000	00000000	00000000
SW09	00000000	00000000	00000000	00000000	00000000	00000000
SW10	00000000	00000000	00000000	00000000	00000000	00000000
SW11	00000000	00000000	00000000	00000000	00000000	00000000
SW12	00000010	00000010	00000010	00000010	00000010	00000010
SW13	00000000	00000000	00000000	00000000	00000000	00000000
SW14	00000000	00000000	00000000	00000000	00000000	00000000
SW15	00000000	00000000	00000000	00000000	00000000	00000000
SW16	00000011	00000011	00000011	00000011	00000011	00000011
SW17	00000000	00000000	00000000	00000000	00000000	00000000
SW18	00000000	00000000	00000000	00000000	00000000	00000000
SW19	00000000	00000000	00000000	00000000	00000000	00000000
SW20	00000000	00000000	00000000	00000000	00000000	00000000
SW21	00000000	00000000	00000000	00000000	00000000	00000000
SW22	00000000	00000000	00000000	00000000	00000000	00000000
SW23	00000000	00000000	00000000	00000000	00000000	00000000
SW24	00000000	00000000	00000000	00000000	00000000	00000000
SW25	00000000	00000000	00000000	00000000	00000000	00000000
SW26	00000000	00000000	00000000	00000000	00000000	00000000
SW27	00000000	00000000	00000000	00000000	00000000	00000000
SW28	00000000	00000000	00000000	00000000	00000000	00000000
SW29	00000000	00000000	00000000	00000000	00000000	00000000
SW30	00000000	00000000	00000000	00000000	00000000	00000000
#2 MENU						
05:	OFF	OFF	OFF	OFF	OFF	OFF
06:	DIAL	DIAL	DIAL	DIAL	DIAL	DIAL
07:	10	10	10	12	10	13
08:	3429	3429	3429	3429	3429	3429
09:	33.6	33.6	33.6	33.6	33.6	33.6
10:	25Hz	25Hz	25Hz	25Hz	25Hz	25Hz

SSSW Default Setting

TYPE	ITALY	SPAIN	PORTUGAL	IRELAND	HUNGARY	SAF
#1 SSSW						
SW01	00010000	00010000	00010000	00010000	00010000	00010000
SW02	00000000	00000000	00000000	00000000	00000000	00000000
SW03	00000000	00000000	00000000	00000000	00000000	00000000
SW04	10000010	10000010	10000010	10000000	10000000	10000000
SW05	00000000	00000000	00000000	00000000	00000000	00000000
SW06	10000000	10000000	10000000	10000000	10000000	10000000
SW07	00000000	00000000	00000000	00000000	00000000	00000000
SW08	00000000	00000000	00000000	00000000	00000000	00000000
SW09	00000000	00000000	00000000	00000000	00000000	00000000
SW10	00000000	00000000	00000000	00000000	00000000	00000000
SW11	00000000	00000000	00000000	00000000	00000000	00000000
SW12	00000010	00000010	00000010	00000010	00000010	00000010
SW13	00000000	00000000	00000000	00000000	00000000	00000000
SW14	00000000	00000000	00000000	00000000	00000000	00000000
SW15	00000000	00000000	00000000	00000000	00000000	00000000
SW16	00000011	00000011	00000011	00000011	00000011	00000011
SW17	00000000	00000000	00000000	00000000	00000000	00000000
SW18	00000000	00000000	00000000	00000000	00000000	00000000
SW19	00000000	00000000	00000000	00000000	00000000	00000000
SW20	00000000	00000000	00000000	00000000	00000000	00000000
SW21	00000000	00000000	00000000	00000000	00000000	00000000
SW22	00000000	00000000	00000000	00000000	00000000	00000000
SW23	00000000	00000000	00000000	00000000	00000000	00000000
SW24	00000000	00000000	00000000	00000000	00000000	00000000
SW25	00000000	00000001	00000000	00000000	00000001	00000000
SW26	10000000	00000000	00000000	00000000	00000000	00000000
SW27	00000000	00000000	00000000	00000000	00000000	00000000
SW28	00000000	00000000	00000000	00000000	00000000	00000000
SW29	00000000	00000000	00000000	00000000	00000000	00000000
SW30	00000000	00000000	00000000	00000000	00000000	00000000
#2 MENU						
05:	OFF	OFF	OFF	OFF	OFF	OFF
06:	DIAL	DIAL	DIAL	DIAL	DIAL	DIAL
07:	10	10	10	10	10	10
08:	3429	3429	3429	3429	3429	3429
09:	33.6	33.6	33.6	33.6	33.6	33.6
10:	25Hz	25Hz	25Hz	25Hz	25Hz	25Hz

SSSW Default Setting

TYPE	GERMAN	FRANCE	CZECH	SLOVENIA
#1 SSSW				
SW01	00010000	00010000	00010000	00010000
SW02	00000000	00000000	00000000	00000000
SW03	00000000	00000000	00000000	00000000
SW04	00000010	00000010	10000000	10000000
SW05	00000000	00000000	00000000	00000000
SW06	10000000	10000000	10000000	10000000
SW07	00000000	00000000	00000000	00000000
SW08	00000000	00000000	00000000	00000000
SW09	00000000	00000000	00000000	00000000
SW10	00000000	00000000	00000000	00000000
SW11	00000000	00000000	00000000	00000000
SW12	00000010	00000010	00000010	00000010
SW13	00000000	00000000	00000000	00000000
SW14	00000000	00000000	00000000	00000000
SW15	00000000	00000000	00000000	00000000
SW16	00000011	00000011	00000011	00000011
SW17	00000000	00000000	00000000	00000000
SW18	00000000	00000000	00000000	00000000
SW19	00000000	00000000	00000000	00000000
SW20	00000000	00000000	00000000	00000000
SW21	00000000	00000000	00000000	00000000
SW22	00000000	00000000	00000000	00000000
SW23	00000000	00000000	00000000	00000000
SW24	00000000	00000000	00000000	00000000
SW25	00000001	00000001	00000000	00000000
SW26	00000000	00000000	00000000	00000000
SW27	00000000	00000000	00000000	00000000
SW28	00000000	00000000	00000000	00000000
SW29	00000000	00000000	00000000	00000000
SW30	00000000	00000000	00000000	00000000
#2 MENU				
05:	OFF	OFF	OFF	OFF
06:	DIAL	DIAL	DIAL	DIAL
07:	10	10	10	10
08:	3429	3429	3429	3429
09:	33.6	33.6	33.6	33.6
10:	25Hz	25Hz	25Hz	25Hz

SSSW Default Setting

TYPE	EUROPE	U.K.	SWEDEN	SWISS	AUSTRIA	DENMARK
#3 NUMERIC						
Param						
02:	10	10	10	10	10	10
03:	15	15	15	15	15	15
04:	12	12	12	12	12	12
05:	4	4	4	4	4	4
06:	4	1	4	4	4	4
09:	6	6	6	6	6	6
10:	5500	5500	5500	5500	5500	5500
11:	3500	3500	3500	3500	3500	3500
13:	1300	1300	1300	1300	1300	1300
15:	120	120	120	120	120	120
#5 TYPE	EUROPE	U.K.	SWEDEN	SWISS	AUSTRIA	DENMARK

SSSW Default Setting

TYPE	NORWAY	HOLLAND	BELGIUM	AUSTRALIA	FINLAND	N.Z.
#3 NUMERIC						
Param						
02:	10	10	10	10	10	10
03:	15	15	15	15	15	15
04:	12	12	12	12	12	12
05:	4	4	4	4	4	4
06:	4	4	4	4	4	4
09:	6	6	6	6	6	6
10:	5500	5500	5500	5500	5500	5500
11:	3500	3500	3500	3500	3500	3500
13:	1300	1300	1300	1300	1300	1300
15:	120	120	120	120	120	120
#5 TYPE	NORWAY	HOLLAND	BELGIUM	AUSTRALIA	FINLAND	N.Z.

SSSW Default Setting

TYPE	ITALY	SPAIN	PORTUGAL	IRELAND	HUNGARY	SAF
#3 NUMERIC Param						
02:	10	10	10	10	10	10
03:	15	15	15	15	15	15
04:	12	12	12	12	12	12
05:	4	15	4	4	4	4
06:	4	3	4	4	4	4
09:	6	6	6	6	6	6
10:	5500	5500	5500	5500	5500	3500
11:	3500	3500	3500	3500	3500	3500
13:	1300	1300	1300	1300	1300	1300
15:	120	120	120	120	120	120
#5 TYPE	ITALY	SPAIN	PORTUGAL	IRELAND	HUNGARY	SAF

SSSW Default Setting

TYPE	GERMAN	FRANCE	CZECH	SLOVENIA
#3 NUMERIC				
Param				
02:	8	8	10	10
03:	15	15	15	15
04:	6	12	12	12
05:	4	4	4	4
06:	4	4	4	4
09:	6	6	6	6
10:	9000	5500	5500	5500
11:	3500	3800	3500	3500
13:	1300	1300	1300	1300
15:	120	120	120	120
#5 TYPE	GERMAN	FRANCE	CZECH	SLOVENIA

3.4 Test Functions

This fax functions for testing individual operations, such as below.

3.4.1 Test mode overview

Test mode can be executed by following the menu items from the display.

a) DRAM tests

Writes data to DRAM image storage areas and reads that data to check operations.

b) Print test

Prints nine different patterns within the print area.

c) Modem, NCU tests

The frequency test, G3 signal transmission test, and Tonal and DTMF signals reception tests, and V.34 G3 signal transmission test.

d) Faculty tests

Test the operation of operation panel, sensor functions, and stamp function.

3.4.2 Test mode flowchart

To operate the test mode, after pressing the Data registration button, press the # button and select “SERVICE MODE”. After this, select “TEST MODE” with the ▲ ▼ buttons, and press the Set button.

To end test mode, press the Stop button followed by the Clear button.

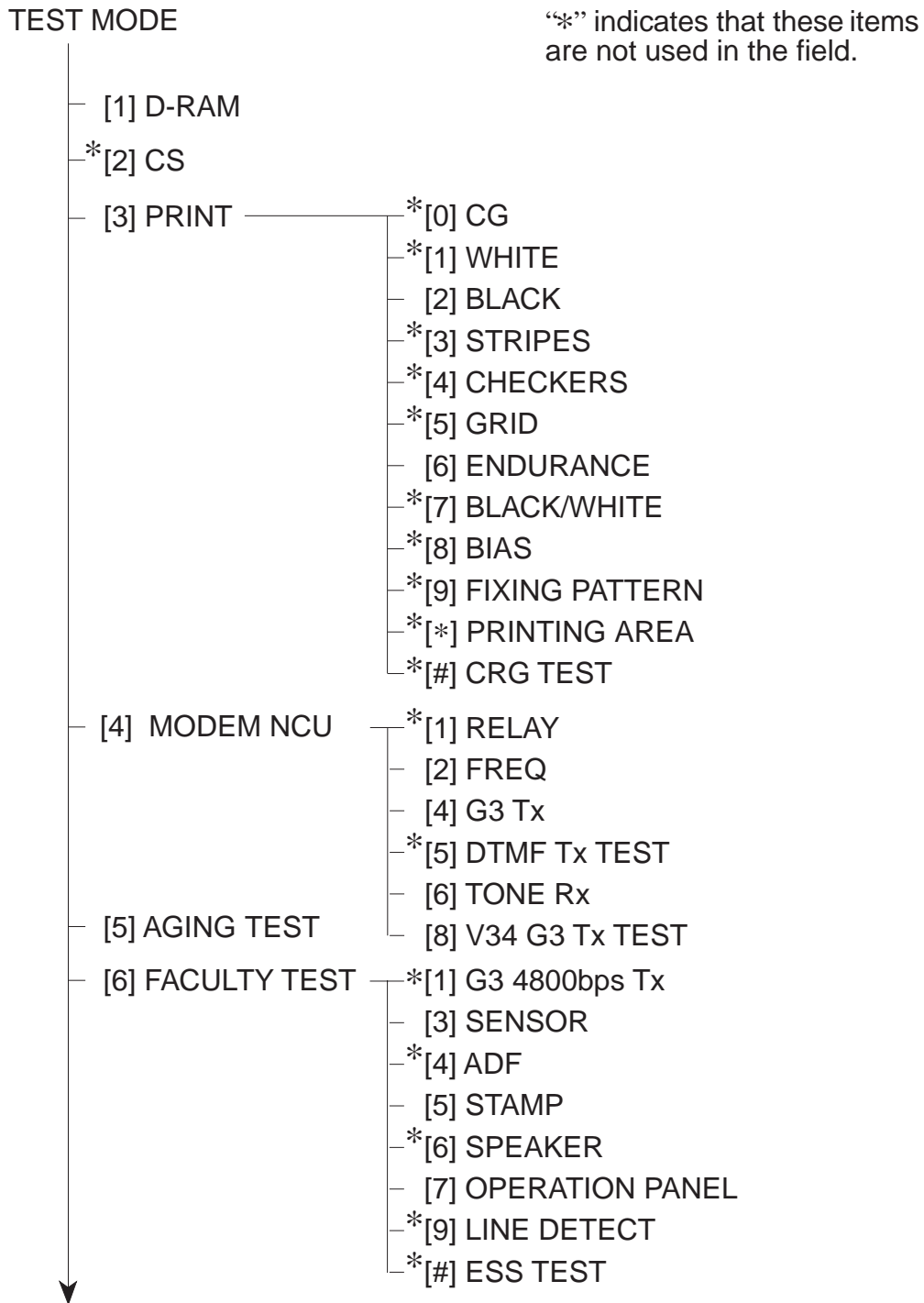

Figure 2-44 Test Mode (1/2)

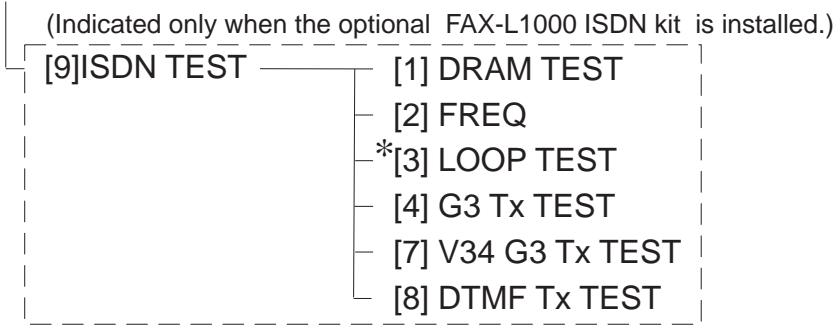

Figure 2-45 Test Mode (2/2)

3.4.3 D-RAM tests

Pressing the numeric key 1 from the test mode menu selects the D-RAM tests. D-RAM Test 1 writes data to the entire D-RAM region and reads it out to check that operations are correct. D-RAM Test 2 just reads data at high speed. This test can be used to check operations when optional memory has been added.

Operating

```

1:D-RAM      3456K
*. . . . . *****
    
```

3456K: D-RAM total memory capacity (bytes)
 (7552 K: When 4 Mbyte Memory added)
 (11648 K: When 8 Mbyte Memory added)

* : Indicates an address for which write testing is complete.
 . : Indicates an address for which read testing is complete.

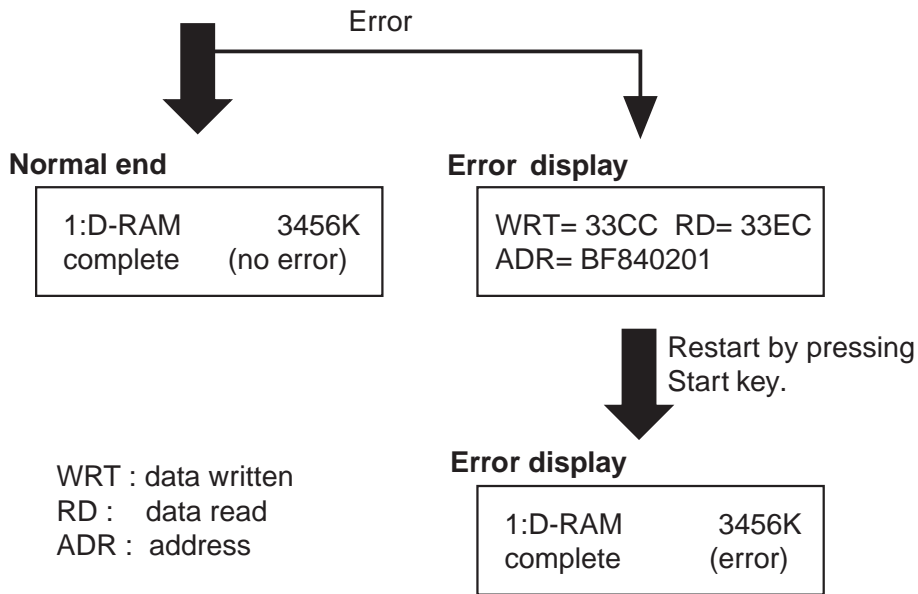

Figure 2-46 D-RAM Test



Before D-RAM test, output all image data in image memory.
 When D-RAM test is performed, all image data are cleared.

3.4.4 Print test

a) Test mode print test

The Print Test menu is selected by pressing the numeric key 3 from the test mode menu. In this test, various print patterns are output from the printer. As service print patterns, press the numeric key 2 from the Print Test menu to select “3-2: BLACK” or press the numeric key 6 to select “3-6: ENDURANCE”. Do not use the other patterns. They are for development and factory use.

Check the following for the print pattern.

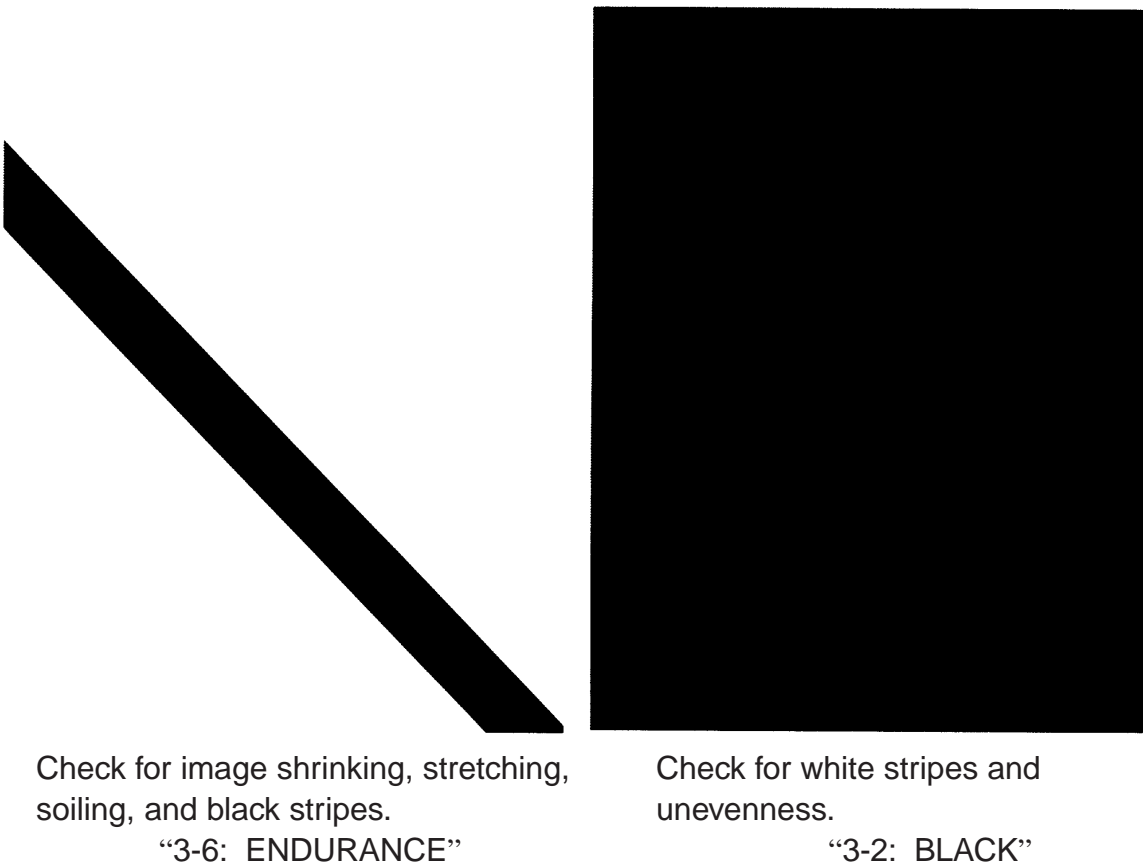
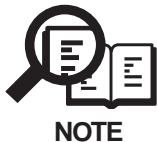

Figure 2-47 Print Pattern Check



After completion of the print test, if the printing was normal, copy a document. If there is any defect in the copied image, there is a defect in the scan section.

3.4.5 Modem and NCU tests

These tests test modem and NCU transmission and reception. The modem tests check whether signals are sent correctly from the modem by comparing the sound of the signals from the speaker with the sounds from a normal modem. Also, you check on the display whether or not the modem correctly detected received tone signals and DTMF signals.

End this test by pressing the Stop button.

Modem test type	Overview
Frequency test	The modem sends tonal signals from the modular jack and the speaker.
G3 signal transmission test	The modem sends G3 signals from the modular jack and the speaker.
Tonal signal/DTMF signal reception tests	The modem detects specific frequencies and DTMF signals received from the modular jack.
V.34 G3 signal transmission test	The modem sends V.34 G3 signals from the modular jack and the speaker.

a) Frequency test

The frequency test menu is selected by pressing the numeric key 2 from the MODEM NCU test menu. Signals of the frequencies below are sent from the modem using the modular jack and the speaker. The frequency can be changed with the numeric keys.

Numeric key	Frequency
1	462 Hz
2	1100 Hz
3	1300 Hz
4	1500 Hz
5	1650 Hz
6	1850 Hz
7	2100 Hz

b) G3 signal transmission test

The G3 signal transmission test menu is selected by pressing the numeric key 4 from the MODEM NCU test menu. The G3 signals below are sent from the modem using the modular jack and the speaker. The Speed can be changed with the numeric keys.

Numeric key	Speed
0	300 bps
1	2400 bps
2	4800 bps
3	7200 bps
4	9600 bps
5	TC7200 pbs
6	TC9600 bps
7	12000 bps
8	14400 bps



NOTE

The transmission level for each frequency follows the service data.

d) V.34 G3 signal transmission test

The V.34 G3 signal transmission test menu is selected by pressing the numeric key **8** from the MODEM NCU test menu. The V.34 G3 signals below are sent from the modem using the modular jack and the speaker by pressing the **Start/Scan** button. The Baud rate can be changed with the numeric keys, and the Speed can be changed with the search keys.

Numeric key	Baud rate
0	3429 baud
1	3200 baud
2	3000 baud
3	2800 baud
4	2743 baud
5	2400 baud

Search key	Speed
	2.4 kbps
	4.8 kbps
	7.2 kbps
▲	9.6 kbps
	12.0 kpbs
	14.4 kbps
	16.8 kbps
	19.2 kbps
	21.6 kbps
	24.0 kbps
▼	26.4 kbps
	28.8 kpbs
	31.2 kbps
	33.6 kbps



NOTE

The transmission level for each baud rate and speed follows the service data.

3.4.6 AGING test

If the numeric key 5 is pressed in the test mode menu, the AGING test is selected. In this test, the contact sensor LED is lit, and the document read motor driven in fine mode. Also, the printer will fine print a endurance pattern. The AGING test will end after the output of the printer is halted by pressing the Stop button.

3.4.7 Faculty tests

The faculty tests are selected by pressing the numeric key **6** from the test mode menu. These tests test the following faculties of this fax.

Test type	Overview
Sensor tests	Test whether the sensors are operating correctly.
Operation panel test	Tests whether the key switches on the control panel are operating correctly.
Stamp test	Tests whether the stamp function is operating correctly.

a) Sensor tests

The sensor test is selected by pressing the numeric key **3** from the faculty test menu. In this test, you can check the status of each sensor of this fax in items 1 to 3 on the display.

You can also check if sensors that use actuators and microswitches are operating correctly by moving the actuator or microswitch.

Items 4 and 5 are not used in the field.

6-3 : SENSOR
[1] --- [6]

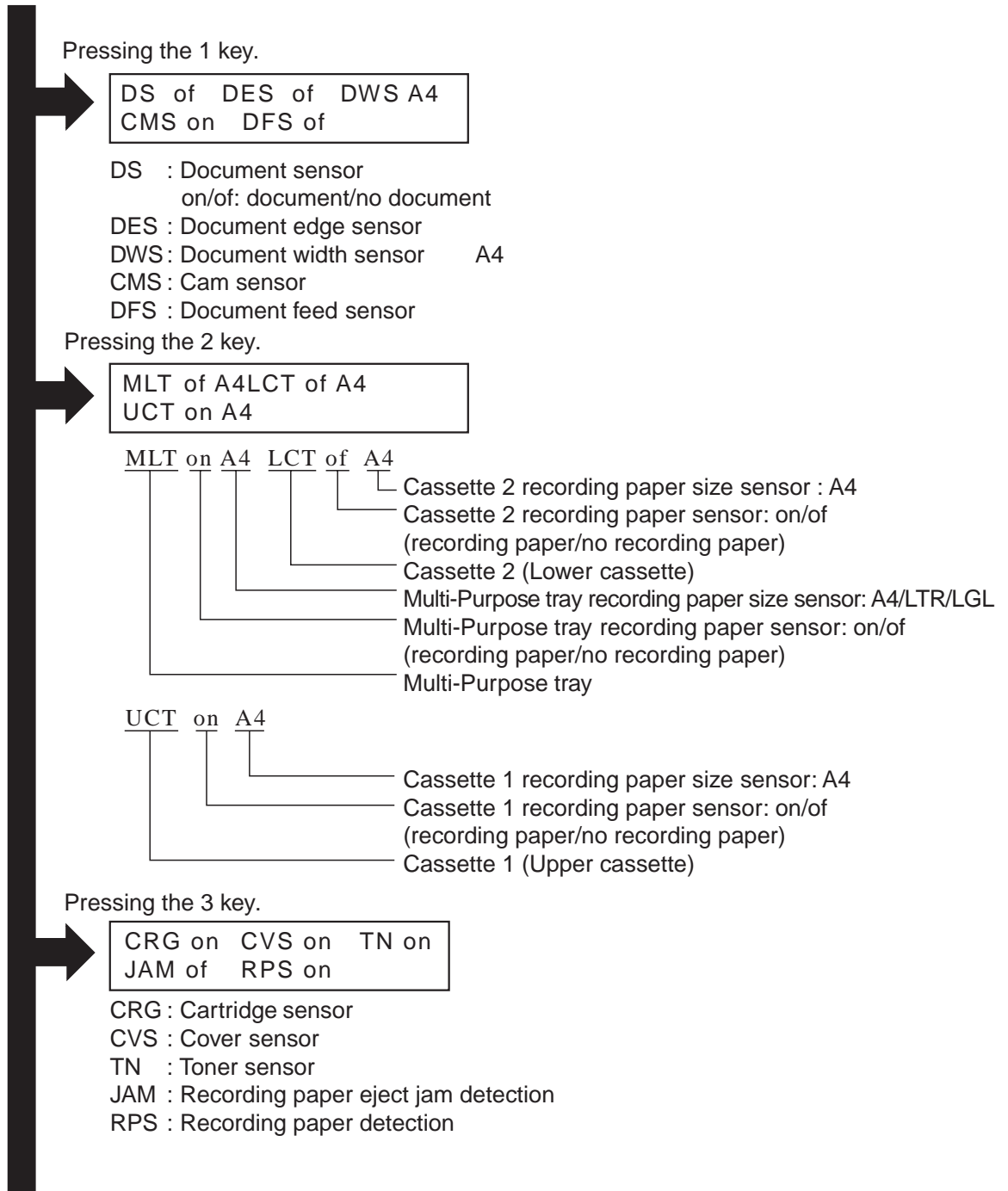

Figure 2-49 Sensor Tests



NOTE

The sensor test 4 to 6 are for factory testing purposes, and so are unrelated in the field.

a-1) Toner sensor test check method

Use the following methods to test “TN on”, and “TN of”.

• **"TN on" check**

- (1) Open the printer cover.
- (2) Insert a cartridge containing toner into the fax.
- (3) Close the printer cover.

• **"TN of" check**

- (1) Open the printer cover.
- (2) Insert the empty cartridge into the fax.
- (3) Close the printer cover.

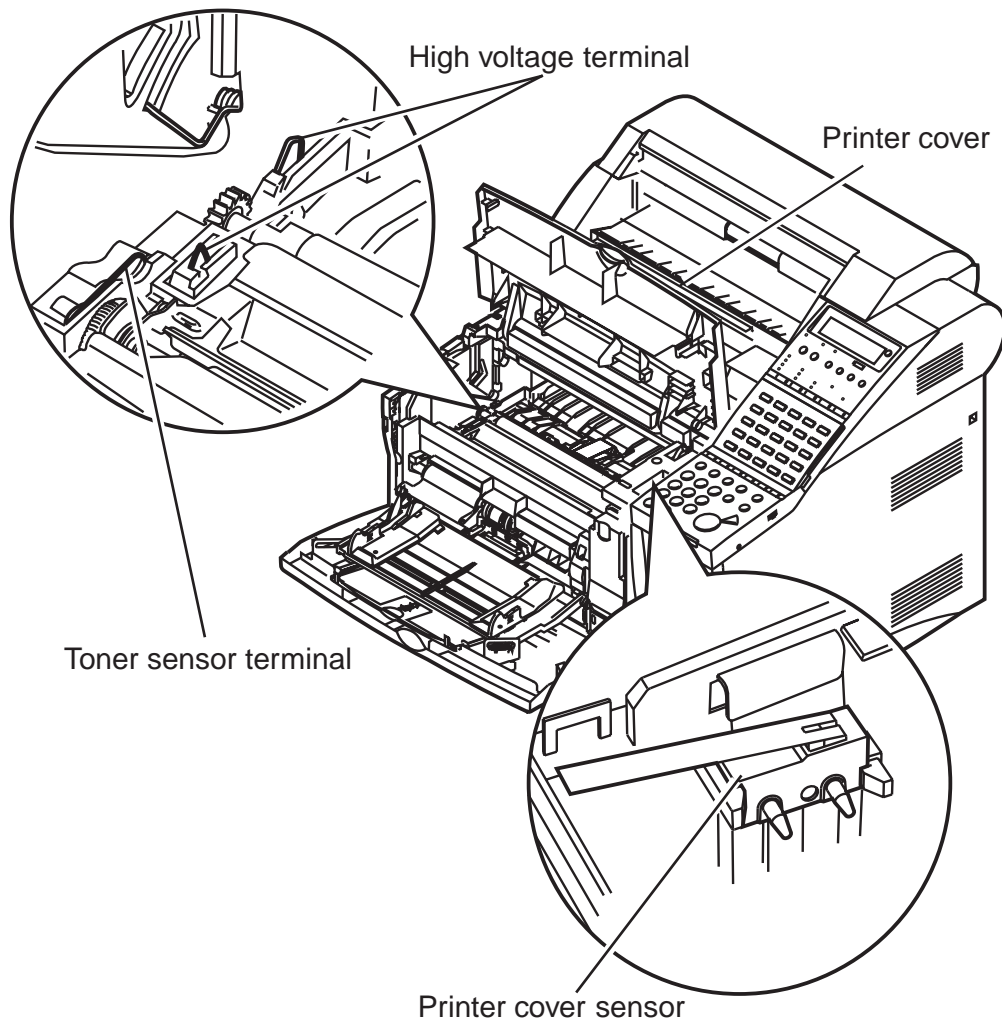

Figure 2-50 Toner Sensor

(3) Close the printer cover.



If the printer cover is closed without a cartridge being inserted, there will be no “TN of” display, and this will not count as a sensor malfunction.

If the printer cover sensor lever is pressed while the cartridge sensor lever is being pressed, high voltage will be applied to the high voltage terminals.

b) Stamp test

The stamp test is selected by pressing the numeric key 5 from the faculty test menu. In this test, check if the stamp function operates correctly. The stamp test can test the following 2 operations.

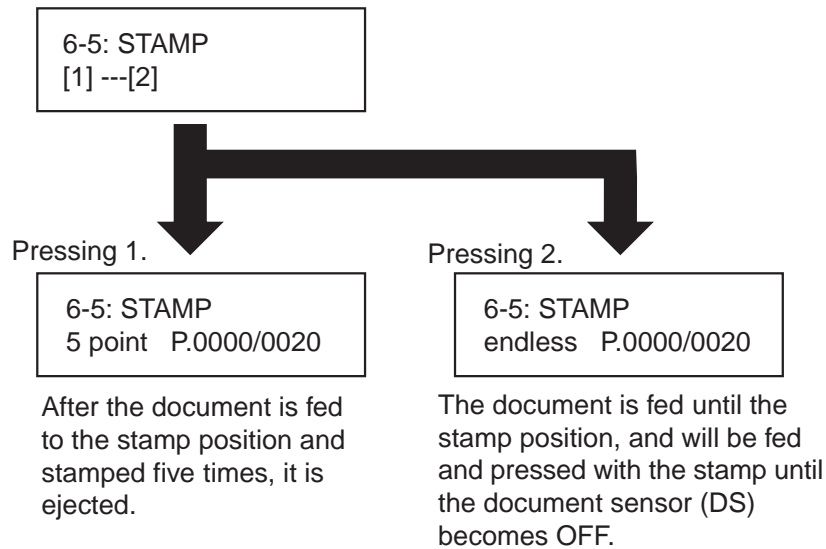

Figure 2-51 Stamp Test



NOTE

The above tests are carried out until the document sensor (DS) goes off.

c) Operation panel tests

The operation panel test is selected by pressing the numeric key 7 from the faculty test menu. In this test, check that the display, LED lamps, buttons and the sensors of one-touch speed dialing panel on the operation panel are operating correctly.

c-1) Display test

Pressing the **Start/Scan** button from the operation panel menu, “H” is displayed 20 characters by 2 lines. The next time the **Start/Scan** button is pressed, all the LCD dots are displayed. Check for any LCD dots in the display that are not displayed.

c-2) LED lamp test

The LED lamp test is selected by pressing the **Start/Scan** button after the display test. When the **Start/Scan** button is pressed, all the lamps on the operation panel light. Check for any LED that does not blink during the test.

c-3) Operation key test

The Operation key test is selected by pressing the **Start/Scan** button after the LED lamp test.

In this test, you press the button corresponding to the displayed character to put it out. The table giving the correspondence between the characters and the buttons is below. When the LEDs for the character for the Ultra Fine-Super Fine-Fine-Standard button, the Darker-Standard-Lighter button, or the Text-Text/Photo button are all lit up, the display goes out.

Character	Operation button	Character	Operation button
1-#	Numeric keys	r	R button
T	Transaction button	\$	Ultra Fine-Super Fine-
R	Redial button		Fine-Standard button
E	Set button	U	Darker-Standard-
L	Clear button		Lighter button
C	Copy button	A	Text-Text/Photo button
O	Hook button	&	Manual Rx button
D	Coded dial button	%	Direct Tx button
<	Down cursor button	G	Go button
>	Up cursor button	S	Shift button
Y	Directory button	M	Menu button
!	Energy saver button	I	Item button
p	PRT. Message button	V	Value button
M	Delete file button	E	Enter/Cancel button
/	Program button		

When all the characters displayed have gone out, the system next starts the one-touch speed dialing button test. The letters a to y are displayed, corresponding to one-touch speed dialing button 1 to 25. Each letter displayed goes out when its corresponding one-touch speed dialing button is pressed.

The letters z, A and B go out when the one-touch speed dialing panels are closed.

In this test, check for operation button whose corresponding character or letter does not go out when the button is pressed.

3.4.8 ISDN test

When numeric key 9 is pressed on the TEST MODE menu, the ISDN test is selected. An ISDN test and a modem test are carried out. Check whether the signal is correctly transmitted from the modem by comparing the signal sound from the speaker with the sound from the speaker of a normal machine. Check whether the received tonal signal and DTMF signal are correctly detected by the modem with the display.

The test is terminated by pressing the stop button.

Modem test type	Overview
DRAM test	Not used
Frequency test	Send a tonal signal from a modem with a speaker.
G3 signal transmission test	Send a G3 signal from a modem with a speaker.
V.34 G3 signal transmission test	Send a V.34 G3 signal from a modem with a speaker.
DTMF transmission test	Send a DTMF signal from a modem with a speaker.

a) DRAM test

This test is not used by this machine.

b) Frequency test

When numeric key 2 is pressed on the ISDN test menu, the frequency test is selected. Press numeric key 1 or 2 to select one of two modems. This test sends signals with the following frequencies from a modem with a speaker. The frequencies can be changed with numeric keys.

Numeric key	Frequency
1	462 Hz
2	1100 Hz
3	1300 Hz
4	1500 Hz
5	1650 Hz
6	1850 Hz
7	2100 Hz



NOTE

The frequency and its output level depend on service data setting.

c) G3 signal transmission test

When numeric key 4 is pressed on the ISDN test menu, the G3 signal transmission test is selected. Press numeric key 1 or 2 to select one of two modems. This test sends a G3 signal from a modem with a speaker. The transmission speed can be changed with numeric keys.

Numeric key	Speed
0	300 bps
1	2400 bps
2	4800 bps
3	7200 bps
4	9600 bps
5	TC7200 bps
6	TC9600 bps
7	12000 bps
8	14400 bps



NOTE

The transmission level of each signal depends on service data setting.

d) V.34 G3 signal transmission test

The V.34 G3 signal transmission test menu is selected by pressing the numeric key 8 from the MODEM NCU test menu. The V.34 G3 signals below are sent from the modem using the modular jack and the speaker by pressing the **Start/Scan** button. The Baud rate can be changed with the numeric keys, and the Speed can be changed with the search keys.

Numeric key	Baud rate
0	3429 baud
1	3200 baud
2	3000 baud
3	2800 baud
4	2743 baud
5	2400 baud

Search key	Speed
	2.4 kbps
	4.8 kbps
	7.2 kbps
▲	9.6 kbps
	12.0 kbps
	14.4 kbps
	16.8 kbps
	19.2 kbps
	21.6 kbps
	24.0 kbps
▼	26.4 kbps
	28.8 kbps
	31.2 kbps
	33.6 kbps



NOTE

The transmission level for each baud rate and speed follows the service data.

e) DTMF signal transmission test

When numeric key 8 is pressed on the ISDN test menu, the DTMF signal transmission test is selected. Press numeric key 1 or 2 to select one of two modems. This test sends a DTMF signal from a modem with a speaker. The DTMF signal is transmitted according to the key pressed.



NOTE

The transmission level of each signal depends on service date setting.

This page intentionally left blank

Chapter 3

Technical Reference

1. SPECIFICATIONS

1.1 Overview

This G3 facsimile transceiver conforms to ITU-T international standards.

1.1.1 Facsimile overview

•Improved speed

This fax unit is equipped with the ITU-T standard V.34 mode which enables transmission speeds up to 33,600bps, more than double the rate of older G3 fax models.

•Full support of ITU-T subaddresses and passwords

You can employ ITU-T subaddresses and passwords to communicate not only with other Canon faxes, but fax machines of other manufacturers as well.

•Economical and quiet

Canon's RAPID Fusing System™ realizes quiet operation while you save money. If the fax machine remains idle for a specified length of time, the fax machine automatically shuts itself down and enters the low energy sleep mode, and will remain in this low energy mode until the fax machine receives a document transmission or until you press the ENERGY SAVER button. You can also use recycled paper in this fax.

•Large paper capacity

A large paper capacity means less time spent loading paper in the paper cassettes. The MP (Multi-Purpose) tray holds a stack of up to 100 sheets. Paper Cassette 1 holds 500 sheets, for a total of 600 sheets. Paper Cassette 2, available as an option, holds another 500 sheets for a total of 1100 sheets. All cassettes and the MP tray can be adjusted to fit a variety of standard paper sizes, and are easy to access and re-fill.

•Quick-on-line TX

Before the fax is finished scanning a long document, it will start dialing and sending the pages that are already scanned. By the time the last page is scanned, the document transmission is well under way.

•Better security with PIN Codes

For PBXs (private branch exchanges) that require PIN (Personal Identification Number) codes to acquire an outside line, you can now turn on the PIN code feature with a user software switch included with the user data settings. For better security, the PIN codes are not displayed on the LCD display during dialing (only a "C" appears), and they do not appear in printed activity reports.

•**Expanded transaction features**

You can create up to 50 private memory boxes and set them up to receive documents. If the other party's fax can use ITU-T subaddresses and passwords, you can set up and use memory boxes even if the other party's fax unit is not a Canon fax.

•**JBIG, Improved image data compression**

JBIG is a new ITU-T standard image data compression method. JBIG's compression method allows data to be compressed more efficiently* than MMR, a conventional compression method. JBIG is especially effective when transmitting halftone image documents. Because the smaller data size requires less transmission time, JBIG saves you time and money.

*Actual compression ratio may vary with image.

1.1.2 Option overview

•**Fax memory**

4MB memory module is available to expand the fax memory capacity.

•**FAX-L1000 Printer Kit**

This option enables your fax to operate as a printer.

•**Printer options**

The Paper Feed Unit, Envelope Feeder, Duplex Unit, FAX-L1000 PostScript Kit, and FAX-L1000 Network Printer Upgrade Kit are available as printer options. Also, 4MB, 8MB, and 16 MB RAM DIMM modules are available to expand the printer memory capacity.

1.2 Configuration and Structure

1.2.1 Product names

LASER beam printing type G3 facsimile

FAX-L1000

1.2.2 External view

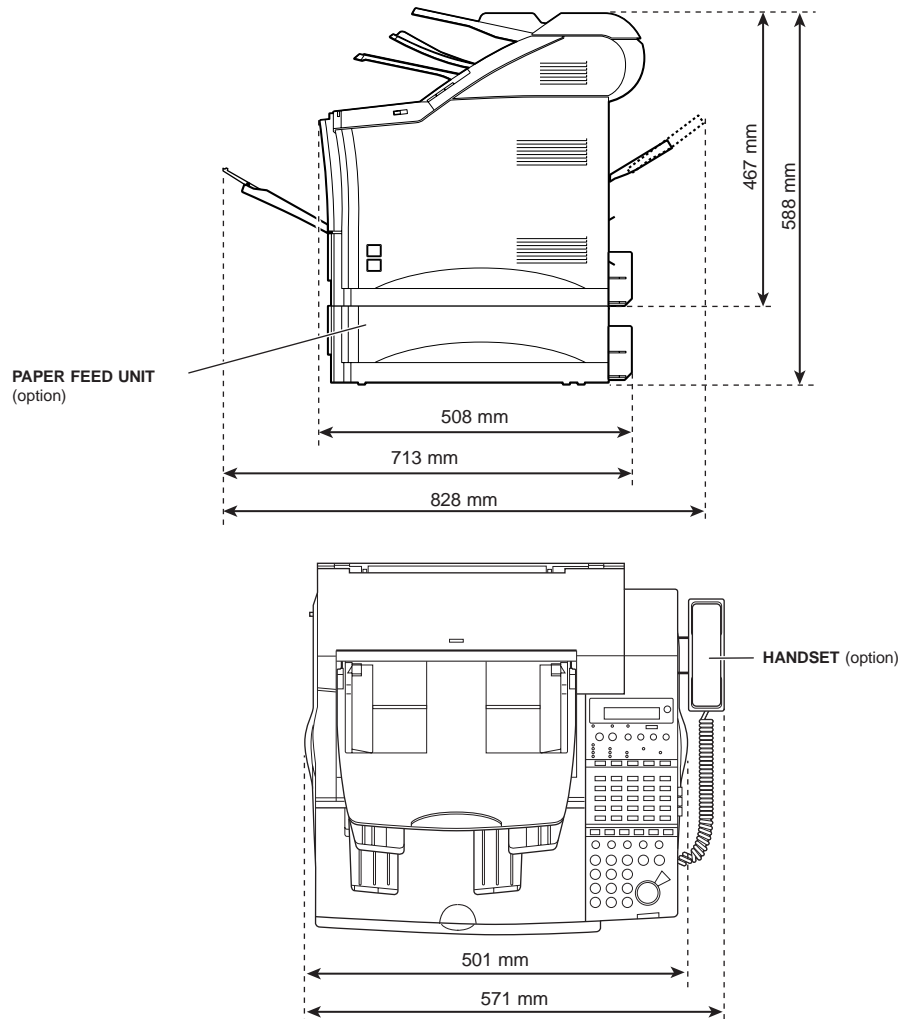

Figure 3-1 External View

1.2.3 Configuration

a) Main unit

Structural section	: Frame, motors, rollers, covers, and others (sensors, etc.)
Control section	: SCNT board, ECNT board
Scanning section	: Contact sensor
Printing section	: LASER beam printer unit
Operation section	: OPCNT board
Power supply	: Power supply unit
Line interface section	: NCU board, Modular board

b) Accessories

- Power Cord (UK, GER, FRN, AUS, AE only)
- Document Feeder Tray
- Document Output tray
- Upper Output Tray
- Destination Labels (2)
- Tray label (UK, GER, FRN, AUS, AE only)
- Modular Line Cord (UK, GER, FRN, AUS, AE only)
- FX6 Toner Cartridge
- User's Guide (UK, GER, FRN, AUS, AE only)
- Mercury Seal (UK only)
- Brochure for supplies (FRN only)

1.3 Specifications and Functions

1.3.1 Basic specifications

Type

Desktop facsimile transceiver

Body color

Art gray

Power source

Voltage	from AC 180 to 264 V
Frequency	from 48 to 62 Hz

Power consumption

Standby (ESS On)	approx. 2W
Standby (ESS Off)	approx. 22W
Operation	approx. 330W (100% of document black copy)
Maximum	approx. 750W

Main unit usage environment

Temperature	from 50.0°F to 90.5°F (10°C to 32.5°C)
Humidity	from 20% to 80% RH
Horizontality	±3° or less

Operating noise

Measured in accordance with ISO standards

Standby	approx. 35 dB(A)
Operating	approx. 54 dB(A)

Dimensions

19.72" (W) × 20.78" (D) × 18.39" (H) (501mm × 508mm × 467mm)
 19.72" (W) × 20.78" (D) × 23.15" (H) (501mm × 508mm × 588mm)
 (With optional paper feed unit)

Not including handset, paper tray

Weight

Approx. 57.32 lbs (26 kg)
 Approx. 72.75 lbs (33 kg) (With optional paper feed unit)
 Not including handset, paper, toner cartridge, document feeder tray, document output tray, upper output tray

1.3.2 Communications specifications

Applicable lines

Analog line (one line)

- PSTN (Public Switched Telephone Network)

Handset (Option)

Handset with no numeric buttons

Transmission method

Half-duplex

Transmission control protocol

ITU-T V.8 protocol V.34 protocol/ECM protocol

ITU-T T.30 binary protocol/ECM protocol

Modulation method

G3 image signals	ITU-T V.27ter (2.4k, 4.8k bps) ITU-T V.29 (7.2k, 9.6k bps) ITU-T V.17 (14.4kbps, 12kbps, TC9.6kbps, TC7.2kbps) ITU-T V.34 (2.4kbps, 4.8kbps, 7.2kbps, 9.6kbps, 12kbps, 14.4kbps, 16.8kbps, 19.2kbps, 21.6kbps, 24kbps, 26.4kbps, 28.8kbps, 31.2kbps, 33.6kbps)
G3 procedure signals	ITU-T V.21 (No.2) 300bps ITU-T V.8, V.34 300bps, 600bps, 1200bps

Transmission speed

33.6k, 31.2k, 28.8k, 26.4k, 24k, 21.6k, 19.2k, 16.8k, 14.4k, 12k, TC9.6k, TC7.2k, 9.6k,
7.2k, 4.8k, 2.4k bps

With automatic fallback function

Coding

MH, MR, MMR, JBIG

Error correction

ITU-T ECM

Canon express protocol

CEP1

Time required for transmission protocol

Mode	Pre-message Protocol *1	Post-message Protocol *2 (between pages)	Post-message Protocol *3 (after pages)
V.8 / V.34	Approx. 6 s	Approx. 1 s	Approx. 1 s
T.30 Standard	Approx. 18 s	Approx. 4 s	Approx. 4 s
CEP1	Approx. 9 s	Approx. 2 s	Approx. 1 s

*1 Time from when other facsimile is connected to the line until image transmission begins.

*2 Post-message (between pages): Time from after one document has been sent until transmission of the next document starts if several pages are transmitted.

*3 Post-message (after last pages): Time from after image transmission is completed until line is switched from facsimile to telephone.

Minimum transmission time

G3	10 ms
G3 (ECM)	0 ms

Transmission output level

from -8 to -15 dBm

Minimum receive input level

-43 dBm

Modem IC

CONEXANT (formerly Rockwell) R288F

1.3.3 Scanner section specifications

Type

Sheets

Sheet dimensions

Maximum	Width 10.98" × length 39.4" (Width 279mm × length 1m)
Minimum	Width 5.83" × length 5.04" (Width 148mm × length 128mm)
Thickness	Multiple pages from 0.002" to 0.005" (0.06mm to 0.13mm) Single page from 0.002" to 0.009" (0.05mm to 0.23mm)

ADF capacity

A4/Letter	50 sheets or less
Legal	20 sheets or less
B4 (AE only)	20 sheets or less
11 inch × 17 inch	20 sheets or less

Effective scanning width

A4	8.19" (208mm)
LTR/LGL	8.43" (214mm)
B4 (AE only)	10.00" (254 mm)

Scanning method

Contact sensor scanning method

Scanning line density

Horizontal:	
Standard/Fine/Superfine	203.2 dpi (8 dots/mm)
Ultrafine	406.4 dpi (16 dots/mm) (Interpolated)
Vertical:	
Standard	97.79 dpi (3.85 line/mm)
Fine	195.58 dpi (7.7 line/mm)
Superfine/Ultrafine	391.16 dpi (15.4 line/mm)

Copy resolution

Memory copy 16 dots/mm × 15.4 line/mm (Interpolated)

Scanning density adjustment

Lighter, Standard, Darker: The density level of each mode can be selected by the user data.



NOTE

Scanning density adjustment is only valid in binary image mode.

Image modes

Binary Documents containing black-and-white characters
Auto halftone Document containing black and white characters, documents containing photographs, mixed black and white characters, and photographs.



NOTE

Auto halftone mode cannot deal with blueprints, tracing paper, blue or green mark highlighting parts.

Half tone

64-gradation error diffusion system (UHQ 6.6)

Scanning range

Item	A4	Letter	Legal	B4 (AE only)
Effective scanning width	8.19"±0.004" (208 ±0.1 mm)	8.43"±0.004" (214 ±0.1 mm)	8.43"±0.004" (214 ±0.1 mm)	10.00"±0.004" (254 ±0.1 mm)
Effective scanning length (Fine, Superfine)	11.54"±0.16" (293 ±4.0 mm)	10.84"±0.16" (275.4±4.0 mm)	13.84"±0.16" (351.6±4.0 mm)	14.17"±0.16" (360.0±4.0 mm)
Effective scanning length (Standard)	11.54"±0.22" (293 ±5.5 mm)	10.84"±0.22" (275.4 ±5.5 mm)	13.84"±0.22" (351.6 ±5.5 mm)	14.17"±0.22" (360.0 ±5.5 mm)
Left margin	0.04" ±0.12" (1.0 ±3.0 mm)	0.04" ±0.12" (1.0 ±3.0 mm)	0.04" ±0.12" (1.0 ±3.0 mm)	0.06" ±0.12" (1.5 ±3.0 mm)
Right margin	0.04" ±0.14" (1.0 ±3.5 mm)	0.04" ±0.14" (1.0 ±3.5 mm)	0.04" ±0.14" (1.0±3.5 mm)	0.06" ±0.14" (1.5±3.5 mm)
Top margin	0.08" ±0.08" (2.0 ±2.0 mm)	0.08" ±0.08" (2.0 ±2.0 mm)	0.08" ±0.08" (2.0 ±2.0 mm)	0.08" ±0.08" (2.0 ±2.0 mm)
Bottom margin (Fine, Superfine)	0.08" ±0.08" (2.0 ±2.0 mm)	0.08" ±0.08" (2.0 ±2.0 mm)	0.08" ±0.08" (2.0 ±2.0 mm)	0.08" ±0.08" (2.0 ±2.0 mm)
Bottom margin (Standard)	0.08" ±0.14" (2.0 ±3.5 mm)	0.08" ±0.14" (2.0 ±3.5 mm)	0.08" ±0.14" (2.0 ±3.5 mm)	0.08" ±0.14" (2.0 ±3.5 mm)

Units are inches with mm shown in parentheses.

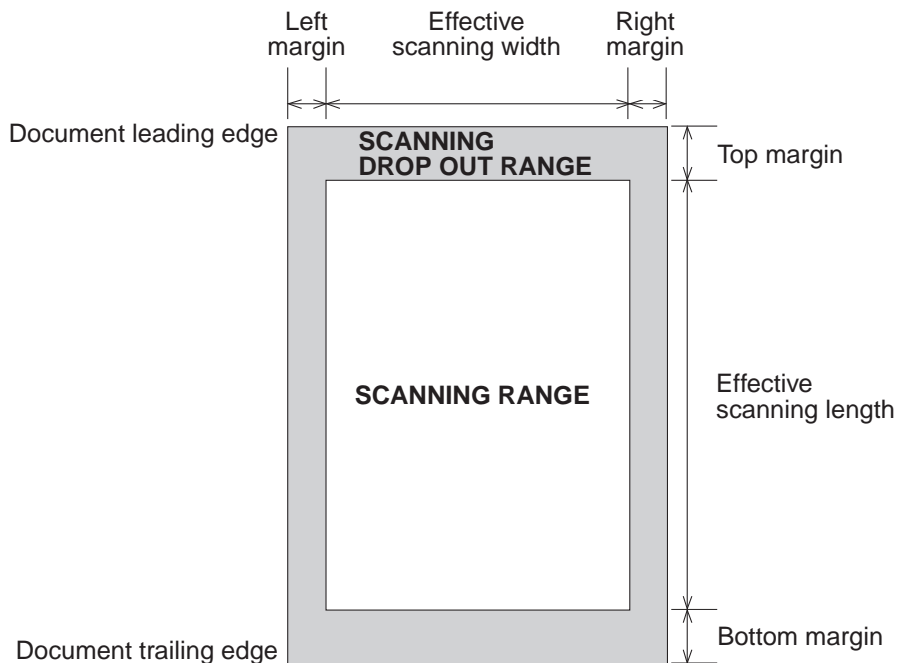

Figure 3-2 Scanning Range



NOTE

Document scanning width "A4/LTR" is set in service data #1SSSW SW 06, bit 4.

1.3.4 Printer section specifications

Paper dimensions

A4	8.27" × 11.69" (210 mm × 297 mm)
Letter	8.50" × 10.98" (216 mm × 279 mm)
Legal	8.50" × 14.02" (216 mm × 356 mm)

Paper cassette capacity

Cassette

2.20" (56mm) or less in stacking height (Approx. 500 sheets)

Multi-purpose (MP) tray

0.39" (10mm) or less in stacking height (Approx. 100 sheets)

Exit tray stacking

A4/LTR	UPPER tray	Approx. 100 sheets
	LOWER tray	Approx. 200 sheets
LGL	UPPER tray	Approx. 100 sheets
	LOWER tray	Approx. 100 sheets

Printing method

Laser beam printer

Printing cartridge

Product name	Canon FX6 Toner Cartridge	
Product code	H11-6431	
Storage conditions	Temperature	From 32.0°F to 95.0°F (0°C to 35°C)
	Humidity	From 35% to 85% RH
Valid period	2.5 years from date of manufacture displayed on carton.	

Toner detection

Antenna method

Printing speed

Letter	Approx. 17 Sheets/min
A4	Approx. 16 Sheets/min

Printing resolution

600dpi Smoothing

Reduction for reception

Fixed reduction (75%, 90%, 95%, 97%)

Auto reduction (70~100%)

Recommended recording paper

Canon Copier LTR/LGL Premium Paper

Weight 75 g/m²
Paper size Letter, Legal
Manufactured by BOISE CASCADE

KANGAS

Weight 80 g/m²
Paper size A4
Manufactured by KANGAS

NEUSIEDLER Canon Paper

Weight 80 g/m²
Paper size A4
Manufactured by NEUSIEDLER

Printing range

Item	A4	Letter	Legal
Effective printing width	8.01 (203.5 mm)	8.24" (209.4 mm)	8.24" (209.4 mm)
Effective printing length	11.34" ±0.12" (288.0 ±3.0 mm)	10.65" ±0.12" (270.4 ±3.0 mm)	13.65" ±0.14" (346.6 ±3.6 mm)
Left margin	0.08" ±0.10" (2.0 ±2.5 mm)	0.08" ±0.10" (2.0 ±2.5 mm)	0.08" ±0.10" (2.0 ±2.5 mm)
Right margin	0.08" ±0.18" (2.0 ±4.5 mm)	0.08" ±0.18" (2.0 ±4.5 mm)	0.08" ±0.18" (2.0 ±4.5 mm)
Top margin	0.08" ±0.08" (2.0 ±2.0 mm)	0.08" ±0.08" (2.0 ±2.0 mm)	0.08" ±0.08" (2.0 ±2.0 mm)
Bottom margin	0.28" ±0.26" (7.0 ±6.5 mm)	0.28" ±0.26" (7.0 ±6.5 mm)	0.28" ±0.27" (7.0 ±6.9 mm)

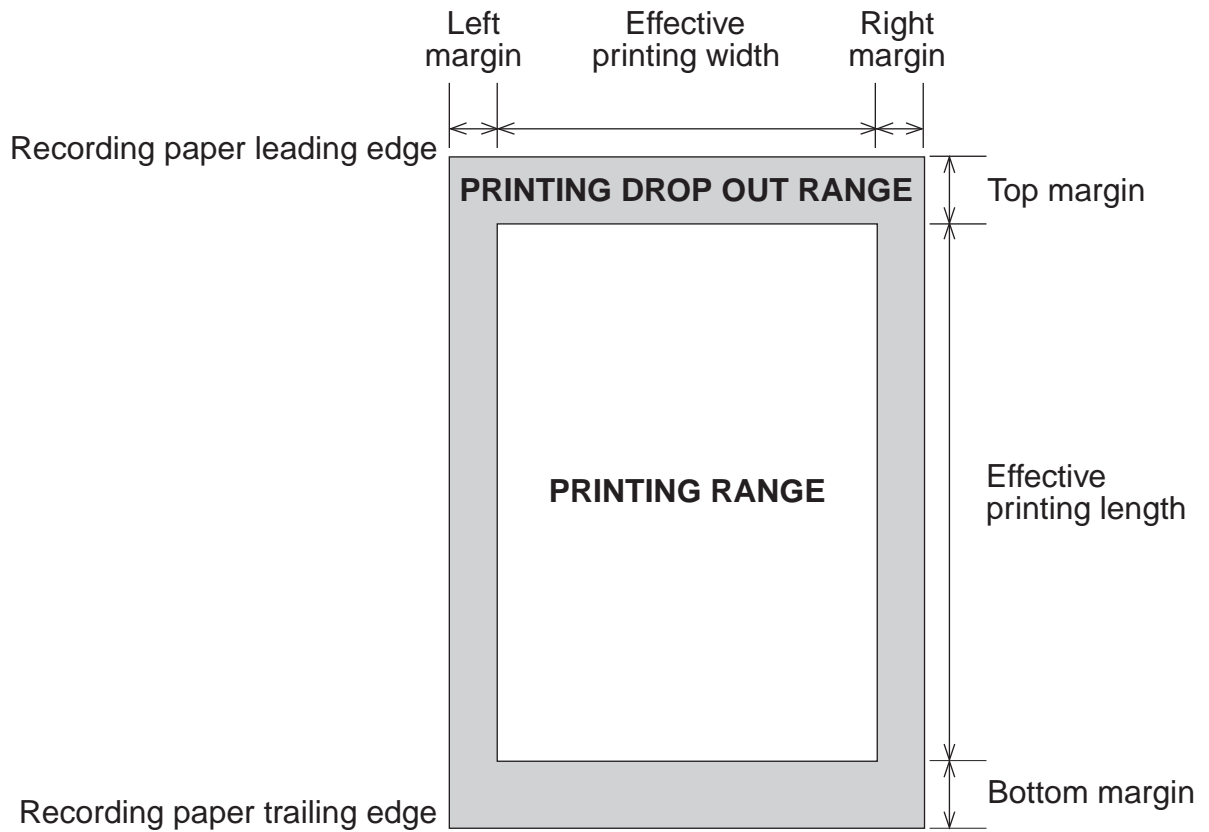

Figure 3-3 Printing Range

1.3.5 Functions

FAX/TEL switching

None

Answering machine connection

None

Memory reception

When receiving Canon FAX Standard Chart No.1

Standard	Max. 192 pages
Memory expanded	Max. 448 pages (4MB option memory mounted)
	Max. 704 pages (8MB option memory mounted)

Polling

Polling transmission

The document is accumulated into memory ahead of time, then transmitted when there is a polling request from the other party.

Polling reception

Receives from a fax in automatic transmission mode

One touch locations	Max. 72
Coded speed dial locations	Max. 128

Confidential reception

Memory reception of images from a transmitting fax that has the confidential transmission function for memory reception.

Box No.	00~99 (Up to 50 boxes can be created.)
Subaddress (ITU-T standard)	Max. 20 digits
Transmission password (ITU-T standard)	Max. 20 digits
Operation password	4 digits

Confidential transmission

Sends transmission images to receiving fax machines with the confidential reception function for memory reception.

Box No.	00~99
Subaddress (ITU-T standard)	Max. 20 digits
Transmission password (ITU-T standard)	Max. 20 digits
Destinations	Max. 200

Remote reception

Method	ID call# (ID input method)
Remote ID (with ID call#)	2 digits

Auto dialing

Telephone number digits	Max. 39 digits
One-touch dial	Max. 72
Coded speed dial	Max. 128
Group dial	Max. 199 (One-touch: 71, Coded speed dial: 128)
Redial	Numeric button redial function (max. 120 digits)

Delayed transmission

Locations	Max. 210 (One-touch : 72, Coded speed dial : 128) Numeric button: 10)
Designated time	Max. 5 time

Broadcast transmission

Locations	Max. 210 (One-touch : 72, Coded speed dial : 128) Numeric button: 10)
Group button addresses	Max. 199 (One-touch : 71, Coded speed dial : 128)

Relay broadcasting originating

Group No.	00~99 (Up to 50 boxes can be created.)
Subaddress (ITU-T standard)	Max. 20 digits
Transmission password (ITU-T standard)	Max. 20 digits
Destinations	Max. 200

Relay broadcasting

Group No.	00~99
Subaddress (ITU-T standard)	Max. 20 digits
Transmission password (ITU-T standard)	Max. 20 digits
Destinations	Max. 200

Closed network

The 8 bit ID is specified by SSSW.

Direct mail prevention

Telephone numbers compared	Telephone numbers registered under one-touch and coded speed dial, and a TSI signal
Number of digits	Lower 6 digits (number of digits can be changed with service data #3)

Activity management

- a) User report
 - Activity management report
 - (Every 40 transactions : Can be separated into Tx and Rx)
 - Activity report (sending / receiving)
 - 1-touch spd dial list
 - Coded speed dial list
 - Group dial list
 - Memory clear list
 - User's data list
 - Multi activity report
 - Transmission reserve list
 - Document memory list

- b) Service report
 - System data list
 - System dump list

Transmitting terminal identification

- Items Time, telephone No. (max 20 digits), senders ID, address, number of transmitted pages (max 3 digits)
- Address Can be registered with one-touch/ coded speed dial keys (16 characters)
- Senders ID 24 characters (1 name)

Display

- Display size 2 rows × 20 digits

Program key

The document mode for scanning or a transmission result report can be registered with the program key.

Redial

- Interval 2 min. (from 2 to 99 min. can be selected in user data)
- Count 2 times (from 1 to 10 times can be selected in user data)

Memory backup

Backup contents	Dial registration data, user data, service data, time
Backup IC	512 kbit SRAM (256 kbit SRAM × 2)
Backup battery	Lithium battery 3.0 V DC / 560 mAh
Battery life	Approx. 5 years

Image data backup

Backup contents	Memory reception, memory copy, delayed transmission and broadcast transmission image data, activity management report
Backup IC	4Mbyte DRAM 4Mbyte DRAM (optional memory)
Backup battery	Rechargeable vanadium lithium battery 3.0V DC/ 50 mAh
Battery life	40 cycles with 100% discharge (Temperature 77°F(25°C))

Time

Management data precision	year/month/day/hour/minute (24 hour display) ±30 sec per month
---------------------------	---

2. THEORY OF OPERATIONS

2.1 Product Overview

2.1.1 Fax main unit

This fax operates on ordinary AC230V household current, and has fax, telephone, and copy functions.

The communication functions include 33.6k bps G3 transmission with ECM, contact scanner scanning with an ADF (auto document feeder) that can consecutively transmit multi-page documents, and a LASER beam printer that can print on plain paper.

2.1.2 Option overview

a) Paper feed unit PF-52

With the paper feed unit installed in the bottom of the main unit, this fax operates as a three-cassette (Upper, lower cassette and multi-purpose tray) machine.

A cassette can hold up to 500*¹ pages of A4, Letter or Legal size recording paper at a time. For example, if Letter size recording paper is loaded in the upper and lower cassettes and Legal size recording paper is loaded in the multi-purpose tray, the paper appropriate to the document received can be fed.

Also, if the same size paper is loaded into each cassettes, up to 1,100 pages can be printed on one loading.

*¹ Loaded paper height of 2.20" (56mm) max.

b) Envelope feeder EF-52

If the envelope feeder is attached to the multi-purpose tray assembly, becomes possible to print envelopes. However, it can not be used to do so when faxing or copying. It can only print envelopes when being used as a printer.

c) Duplex unit DU-52

By attaching a duplex unit, double-sided printing becomes possible. However, this function is not possible when faxing or copying. Double-sided printing is only possible when being used as a printer.

d) FAX-L1000 ISDN KIT

Connection to an ISDN line is possible when the optional FAX-L1000 ISDN KIT is installed.

e) FAX-L1000 Printer Kit

This option enables your fax to operate as a printer.

f) 4MB memory kit

The image memory can be expanded by installing 4MB memory boards. Two memory boards can be installed in the fax machine.

g) Verification stamp unit

The verification stamp unit stamps a check mark near the trailing edge of the scanning side of each document to verify that all documents are transmitted correctly without any errors, such as double feeding. This unit is installed near the contact sensor in the lower reader frame unit.

2.1.3 Consumables

a) Toner cartridge

A new type of toner cartridge (FX6) is used. It is not compatible with the previous types of cartridges.

Main unit

FAX-L1000

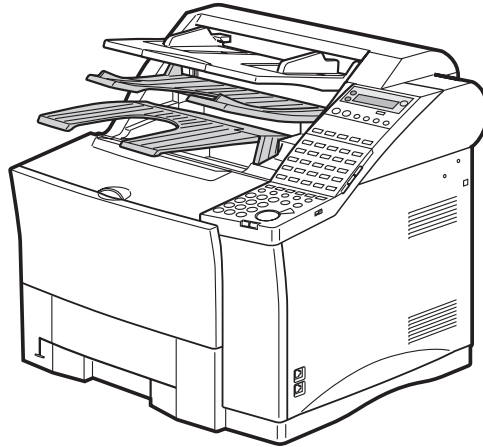

Option

PAPER FEED UNIT PF-52

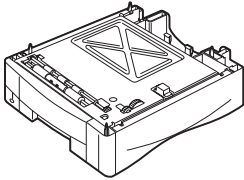

DUPLEX UNIT DU-52

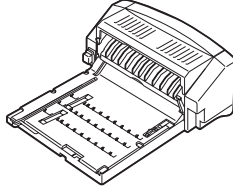

ENVELOPE FEEDER EF-52

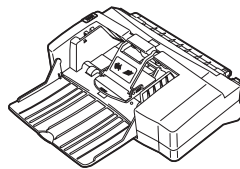

FAX-L1000 ISDN KIT

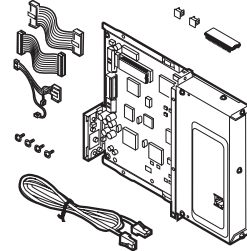

OPTION MEMORY VII (4MB)

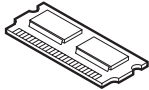

STAMP UNIT

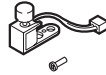

FAX-L1000 Printer kit

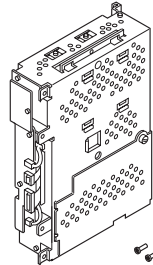

FAX-L1000 Network Printer Upgrade kit

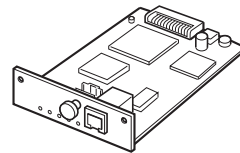

FAX-L1000 PostScript kit

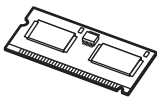

RAM DIMM Module

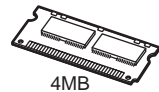

4MB

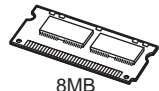

8MB

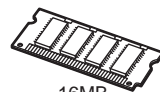

16MB

Consumables

FX6 toner cartridge

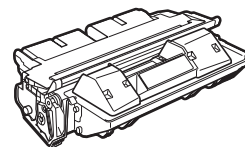

Figure 3-4 Product Overview

2.2 Mechanical Overview

The mechanical section of this fax comprises the scanner section, the pickup section, and the printer section.

2.2.1 Unit layout diagrams

a) Scanner section

The scanner section has an ADF (auto document feeder) function and can automatically feed 50 sheets of A4 or letter size documents (20 sheets of B4 (AE only) or legal size documents). This section has a stopper mechanism to hold documents properly. A contact sensor scans one document in about 1.4 seconds (standard).

b) Pickup section

The pickup section feeds recording paper from a multi-purpose tray or front cassette to the printer section. The universal type multi-purpose tray can hold up to 100 pages at a time, or paper to a maximum height of 0.39" (10 mm), whichever is the lesser, and the guide positions can be adjusted for letter, A4, and legal paper sizes. The front cassette can hold up to 500 pages at a time, or paper to a maximum height of 2.20" (56 mm). The recording paper is fed into the printer unit one page at a time, powered by the main motor.

c) Printer section

The printer section uses a new LASER beam printer engine.

It uses the surf fixing system that activates the heater only when printing to save power and shorten the wait time.

2.2.2 Document and recording paper flow

a) Document flow

When the document is inserted into the document insertion slot at the main unit, it is fed by the pick-up roller to the separation roller, and one page at a time is separated. Then, the document is fed onto the contact sensor unit by the feed roller, and ejected by the eject roller to the document output tray from the document outlet at the front of the main unit.

b) Recording paper flow

When recording paper is fed from the paper cassette, one sheet of paper is separated from the others and transferred by the pickup roller and separation rollers. When it is fed from the multi-purpose tray, one sheet of paper is separated from the others and transferred by the pickup roller and separation pad. It is then inverted by the feed roller and at the same time fed from the pickup section to the printer section. Then, after the recording paper is printed by the printer section, toner cartridge and fixing section, the paper is ejected by the face-down delivery roller and the paper feed roller at the recording paper outlet on the main unit.

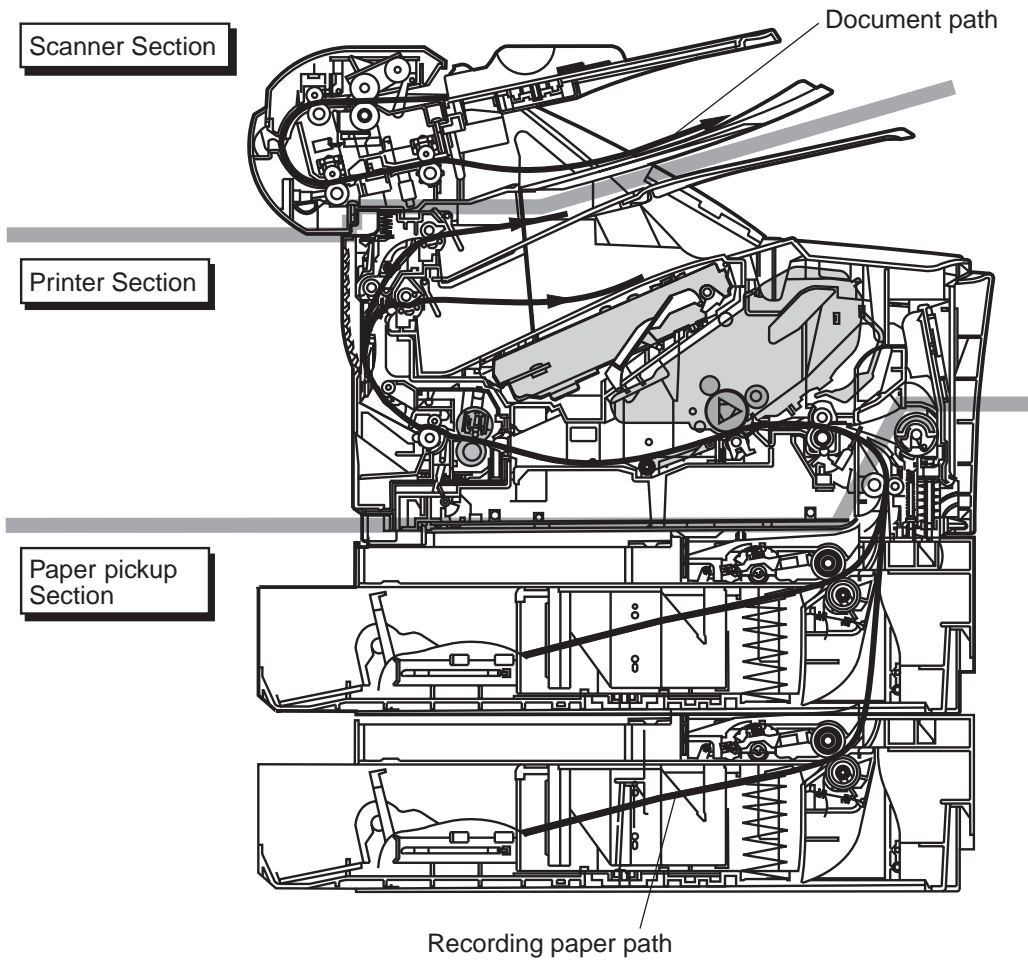

Figure 3-5 Paper Path

2.2.3 Drive system layout

a) Scanner section

The power of the document read motor is transmitted by belt and gear to drive the pick-up, separation, feed, and eject rollers. The rotation of pick-up roller is controlled by a cam, DC motor and separation roller arm.

b) Pickup section

The power of the main motor is transmitted by gears to drive the cassette's pickup, separation and feed rollers. The rotation of each roller is controlled by a solenoid.

c) Printer section

The power of the main motor is transmitted by gears to drive the transfer charging roller, the toner cartridge photosensitive drum, the primary charging roller, the developing cylinder, the fixing pressure roller, the face-down delivery roller and the paper feed roller. The face-down delivery roller and the paper feed roller are driven by power transmitted by gear from the main motor.

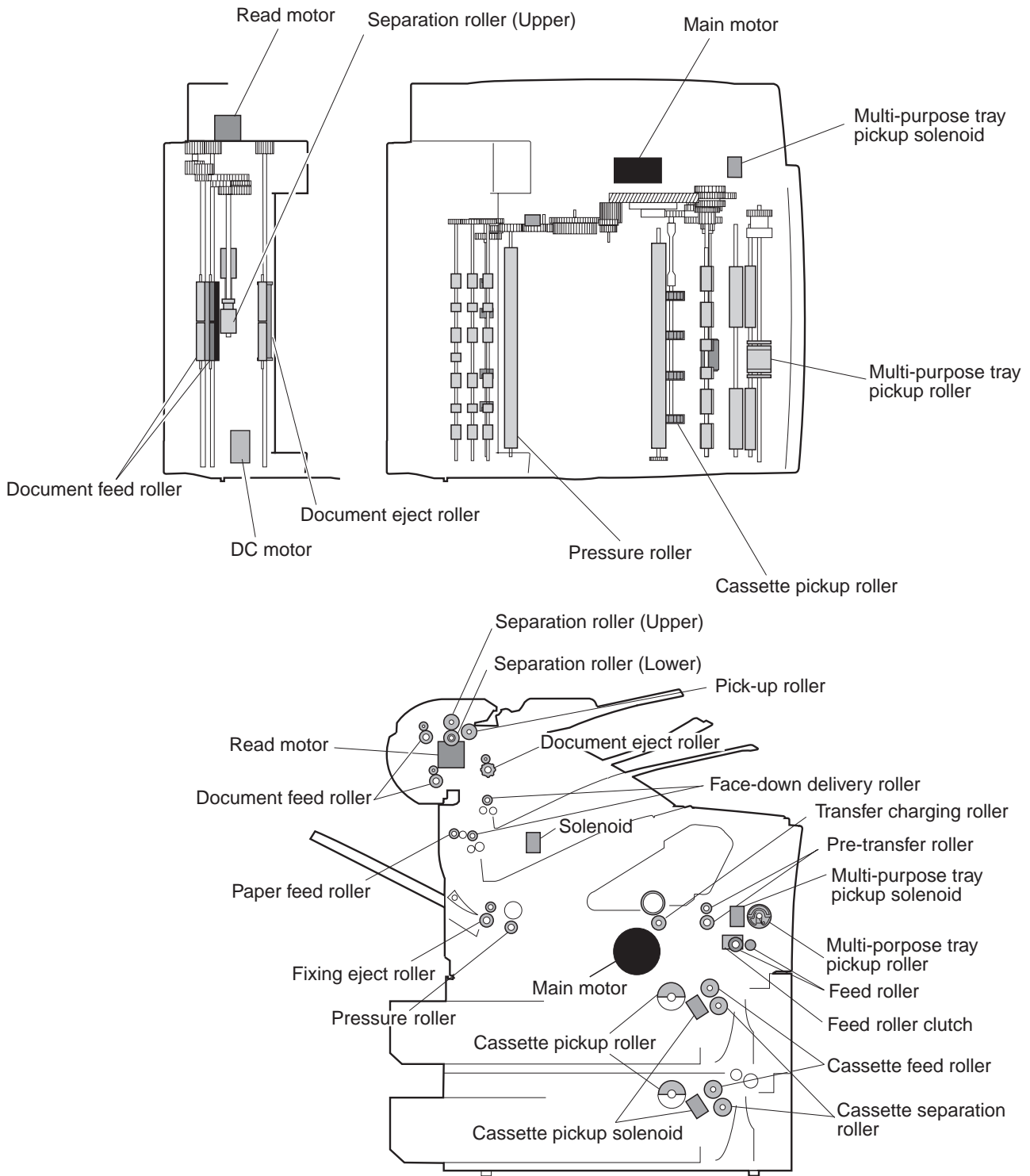

Figure 3-6 Drive System Layout

2.2.4 Electrical system layout

a) Board layout

a-1) SCNT board

The SCNT board, which contains the system controller which controls the entire fax, is attached to the right side of the main unit.

a-2) NCU board

The NCU board, which controls the telephone line, is attached to the right side of the main unit behind the SCNT board.

a-3) ECNT board

The ECNT board, which controls the printer assembly motor, solenoid, toner cartridge, and fixing unit, is attached to the bottom of the main unit.

a-4) OPCNT board

The OPCNT board, which controls the operation panel, is attached to the inside of the operation panel.

a-5) Power supply unit

The power supply unit, which controls the main unit's power supply, is attached to the right side of the main unit, to the right of the SCNT board.

a-6) Modular board

The Modular board, which is the telephone line and NCU board relay, is attached to the right side of the main unit, in front of the SCNT board.

a-7) TWINS board

The TWINS board relays the SCNT board, Power supply unit, and ECNT board.

a-8) Paper size detection board 1 (Cassette 1)

The paper size detection board 1 is attached to the lower right side of the main unit.

a-9) Paper size detection board 2 (Cassette 2)

The paper size detection board 2 is attached to lower right side of the paper feed unit PF-52.

a-10) Sensor board

The sensor board, is attached to the ADF assembly (Upper reader frame unit).

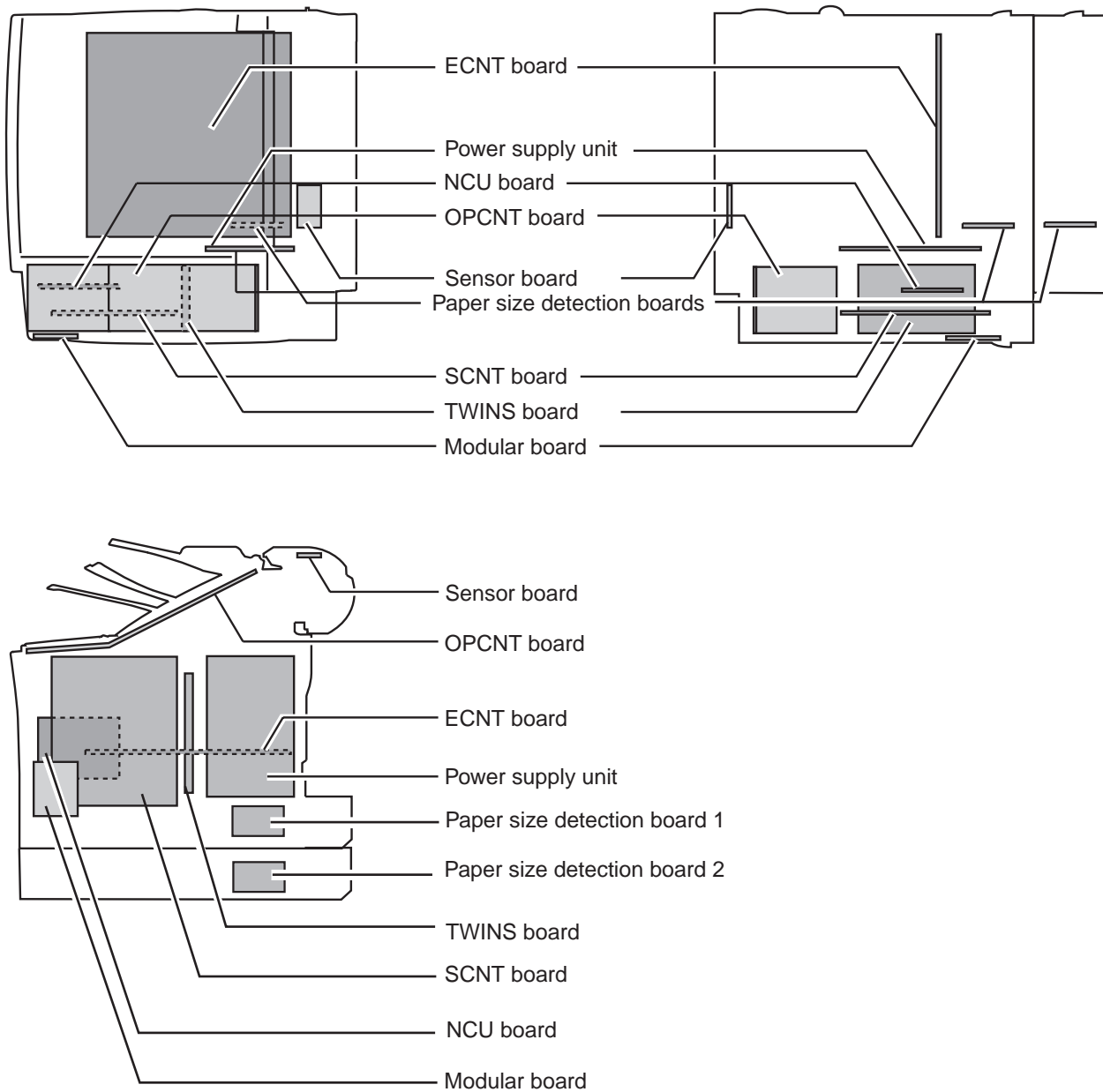

Figure 3-7 Electrical System Layout

b) Sensor layout

b-1) Contact sensor

This contact sensor (CS) horizontally scans documents up to Letter size 8.42" (214mm) (B4 size 10.00" (254 mm) for AE) at a horizontal scanning resolution of 8 dots/mm.

b-2) Document sensor (DS)

This sensor, which detects the presence/absence of a document, is attached to the ADF section (Upper reader frame unit) sensor board.

b-3) Document width sensor (DWS) (AE only)

This sensor, which detects the width of the document, is attached to the ADF section (Upper reader frame unit) sensor board.

b-4) Document feed sensor (DFS)

This sensor, which detects the feed condition of the document, is attached to the ADF section (Upper reader frame unit) sensor board.

b-5) Document edge sensor (DES)

This sensor, which detects the lead and rear edges of a document when it is passing through the ADF, is attached to the ADF section (Base reader frame unit).

b-6) Cam sensor

This sensor, which detects the condition of the cam in the ADF section, is attached to the ADF section(Upper reader frame unit).

b-7) Panel sensor (A / B / C)

These sensors detect whether the one-touch speed dialing panels are open or closed, and are located on the OPCNT board.

b-8) Multi-purpose tray paper sensor

This sensor, which detects the presence/absence of recording paper in the multi-purpose tray, is attached to the multi-purpose pick-up assembly.

b-9) Cassette recording paper sensor

This sensor, which detects the presence/absence of recording paper in the cassette, is attached to the paper feed section.

b-10) Pre-feed sensor

This sensor, which detects the feed condition of the recording paper, is attached to the paper feed section.

b-11) Top of page sensor

This sensor, which detects the rear edge of the recording paper when it passes through the inside of the main unit, is attached to the paper feed section.

b-12) Recording paper eject sensor 1

This sensor, which detects whether or not the recording paper has been fed as far as the fixing unit, is attached to the ECNT board.

b-13) Recording paper eject sensor 2

This sensor, which detects whether or not the recording paper has passed through the fixing unit, is attached to the fixing unit.

b-14) Recording paper overload release sensor

This sensor, which detects that the lower delivery tray is full, is attached to the recording paper lower delivery assembly.

If the recording paper in the lower delivery assembly becomes filled to capacity, this sensor switches ON.

After that, if the recording paper continues to be loaded and reaches an overloaded condition, recording paper overload sensor 1 switches ON. If this overloaded condition is detected, the delivery of recording paper switches from the lower delivery assembly to the upper delivery assembly.

After delivery is switched to the upper delivery assembly, even if the recording paper overload sensor 1 which detects overloading of the lower delivery assembly is switched OFF by some factor (the user removes some of the paper from the lower delivery assembly, upward-curved paper flattens with time, etc.), the recording paper overload release sensor will not switch OFF, and so delivery of recording paper will not return from the upper delivery assembly to the lower delivery assembly.

b-15) Recording paper overload sensor 1

This sensor, which detects the delivery situation of the recording paper in the lower tray, is attached to the delivery assembly.

b-16) Recording paper overload sensor 2

This sensor, which detects the delivery situation of the recording paper in the upper tray, is attached to the delivery assembly.

b-17) Printer cover sensor

This sensor, which detects the opening/closing of the printer cover, is attached to the main unit frame.

b-18) Cassette recording paper size sensor

This sensor, which detects the cassette is installed and the size of the recording paper which has been set in the cassette, is attached to the paper size detection board.

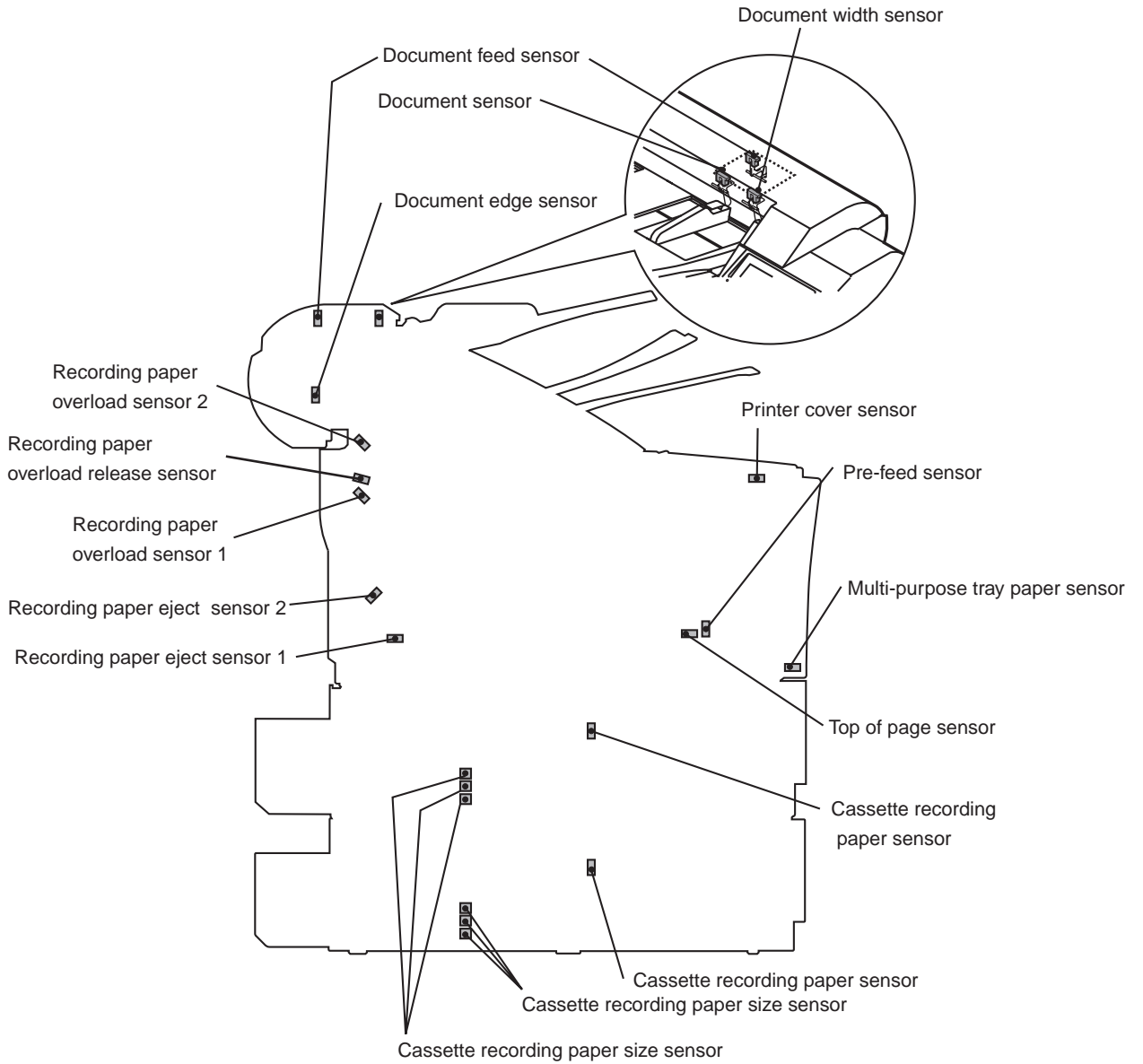

Figure 3-8 Arrangement of Sensors

2.3 Scanner Section

The scanner section comprises the document feed section and the optical section.

2.3.1 Document feed section

a) Document feed function

a-1) ADF (auto document feed) function

The ADF feeds up to 50 pages^{*1} of documents placed on the document feeder tray, separates each page with the separation roller (upper) and separation roller (lower), passes the page over the contact sensor unit, then ejects the paper to the document output tray.

^{*1}: Letter/A4 size: up to 50 pages, Legal size: up to 20 pages

B4 size (AE only): up to 20 pages

a-2) Document jam detection function

The document jam detection function is to detect eject paper jams and over-length documents with document sensor (DS) and document edge sensor (DES).

b) Document feed section structure

b-1) ADF structure

In the ADF structure, the rollers needed for document pickup, document separation, document feed, and document ejection are driven via gears with the power for the stepping pulse type document feed motor.

The document stopper is installed to position documents correctly and reduce feed errors due to documents inserted too deeply or insufficiently. When document transfer begins, the document stopper goes up, and documents are separated one at a time and fed with pickup roller and the separation rollers.

After separation, the document is fed to the contact sensor section with the document feed roller. The document feed roller turns faster than the separation roller to prevent the document from slackening between the document feed roller and the separation roller. The separation roller is pulled by the document feed roller.

The document fed to the contact sensor section is pressed by a white sheet above the contact sensor to prevent it from lifting during scanning. To correct shading, the white level is detected from the white sheet immediately before the paper passes through the contact sensor.

The document scanned with the contact sensor is delivered to the output tray with the document eject roller.

The ADF is controlled by the SCNT board's main CPU counting the document feed motor step pulses, and the photo-interrupter type document edge sensor^{*2}, document sensor^{*3} and document feed sensor^{*4} equipped with actuator arms detecting the document feed status.

^{*2}: DES ^{*3}: DS ^{*4}: DFS

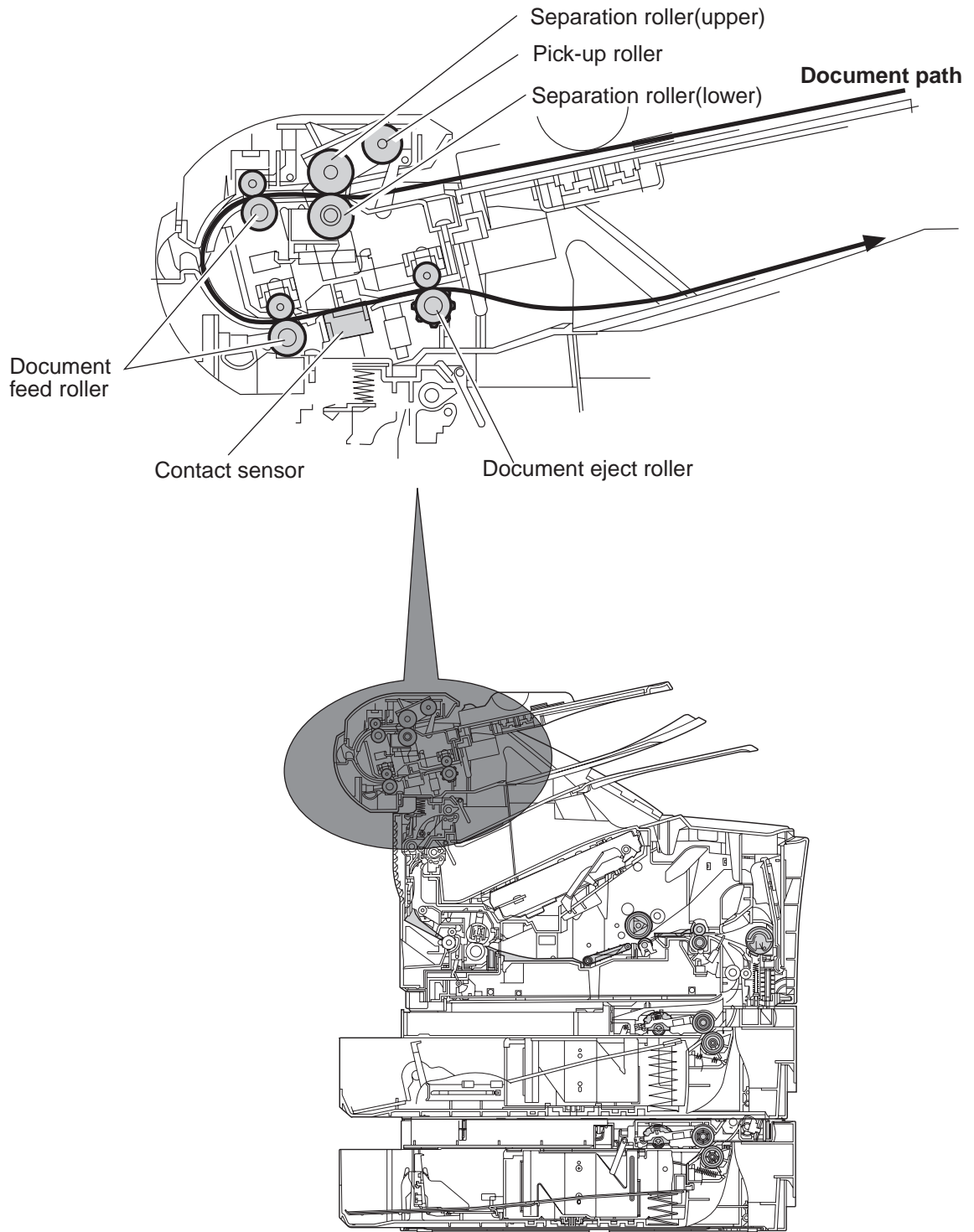
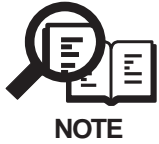

Figure 3-9 Document Feed Section



Document stopper movement

- (1) When documents are set (Fig. A)

The document stopper on the ADF section (Upper reader frame) stops the document which is inserted into the document insertion opening, preventing it from being pushed in too far.

- (2) When the stopper goes up (Fig. B)

The cam is rotated by the DC motor, and the document stopper moves into a free condition. At this time, the pick-up roller moves down and the document is fed.

- (3) When document feed begins (Fig. C, D)

And the document feed sensor which deeds the document comes ON, the pick-up roller moves up, and the document stopper maintains a free condition.

- (4) After the document feed ends (Fig. E)

If all of the documents are delivered, the cam is rotated by the DC motor, the pick-up roller moves up and down, and the stopper returns to its original condition.

Initializing the document stopper

The projection on the upper document feed roller needs to be set (initialized) to the optimum position to operate the document stopper properly.

The fax machine performs initialization when the power is turned on, and after a document is ejected. The initialize operation is described in (4) above.

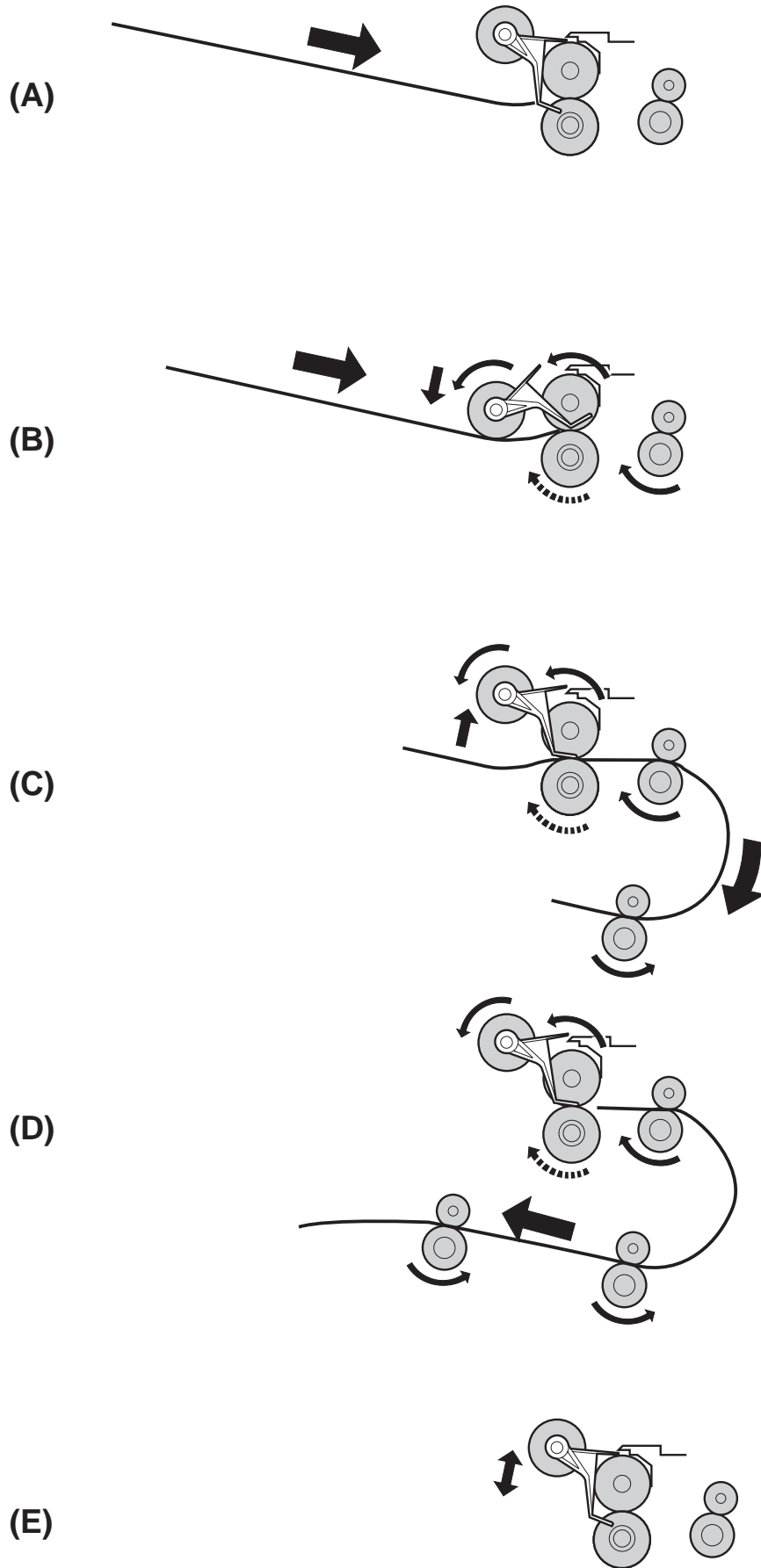

Figure 3-10 Stopper Movement

b-2) Document jam detection

The document edge sensor detects such document jams as pickup jams and document too long errors.

A “pickup jam” means the document edge sensor cannot detect the leading edge of the document within 15 seconds after document feeding begins.

A “document too long error” means that the document edge sensor cannot detect the trailing edge of the document, even after the stepping pulses for feeding more than 39.4" (1000 mm) of document have been transmitted.



NOTE

Document Jam Processing

If a document jam occurs, the fax stops the document read motor and ADF operations, displays the error, and the Error lamp flashes in red.

For a pickup jam, “CHECK DOCUMENT” is displayed. For document too long error, “DOCUMENT TOO LONG” is displayed.

If the document is being copied when a document jam occurs, the image data scanned in and stored in memory are erased for all pages, and print operations are stopped. Image data stored in memory when memory transmission, or delayed transmission, or sequential broadcasting, is erased from memory at the point when the jam is detected.

2.3.2 Optical section

a) Functions

a-1) Document scanning

For document scanning, the Contact Sensor (CS) horizontally scans documents up to LTR size 8.42" (214mm)(B4 size 10.00" (254mm) for AE) at a horizontal scanning resolution of 8 dots/mm (Standard, Fine and Superfine) or 16 dots/mm (Ultrafine).

Vertical scanning resolution is fixed by selecting resolution button on the operation panel. The document scanning speed changes according to the resolution setting, and scanning will be done at either 97.79 lines/inch (3.85 lines/mm) for Standard, 195.58 lines/inch (7.7 lines/mm) for Fine, and 391.16 lines/inch (15.4 lines/mm) for Superfine and Ultrafine. The scanned data are sent to the SCNT board, and image processing carried out by the image processing IC (UHQ 6.6). When this IC is set for Text/Photo, areas of the document that contain photographs are automatically processed with 64 gradations of gray, rather than just two, black and white. This results in a much better reproduction of the photograph.

a-2) Prescanning

The variation of contact sensor output during document scanning is corrected by the prescan function.

a-3) Automatic slice level

The slice level for determining the white and black areas is set automatically to scan density correctly regardless of the document paper color.

b) Structures

b-1) Contact sensor

The contact sensor is designed to be dust-free, so that dust and other such minute particles cannot find their way inside the contact sensor housing, to settle on the sensor surface.

The contact sensor consists of an LED array that emits light for scanning, a lens that distributes light from the LED array uniformly in the horizontal direction, a contact glass that refracts the light to the document, a rod lens array that receives the light reflected from the document, and a phototransistor array that receives reflected light.

The LED array of the contact sensor is controlled by the SCNT board.

The phototransistor array consists of 1728 phototransistors (2054 phototransistors for AE) and 11 driver circuits (13 driver circuits for AE) that amplify the light reception output in units of 158 phototransistors.

The output from the 13 driver circuits is converted to serial data and sent to the SCNT board.

b-2) Prescanning

At the start each communication, the prescan function reads in one line of the white sheet pasted to the document feed section at the top of the contact sensor, stores the contact sensor output variation correction value into memory, and corrects contact sensor output for the image then read in.

b-3) Automatic slice level

The SCNT board image processing IC has a built-in ABC (Automatic Background Control) circuit. This circuit sets the slice level for each line of image data read, so that gradations can always be reproduced clearly, no matter the background color of the paper.

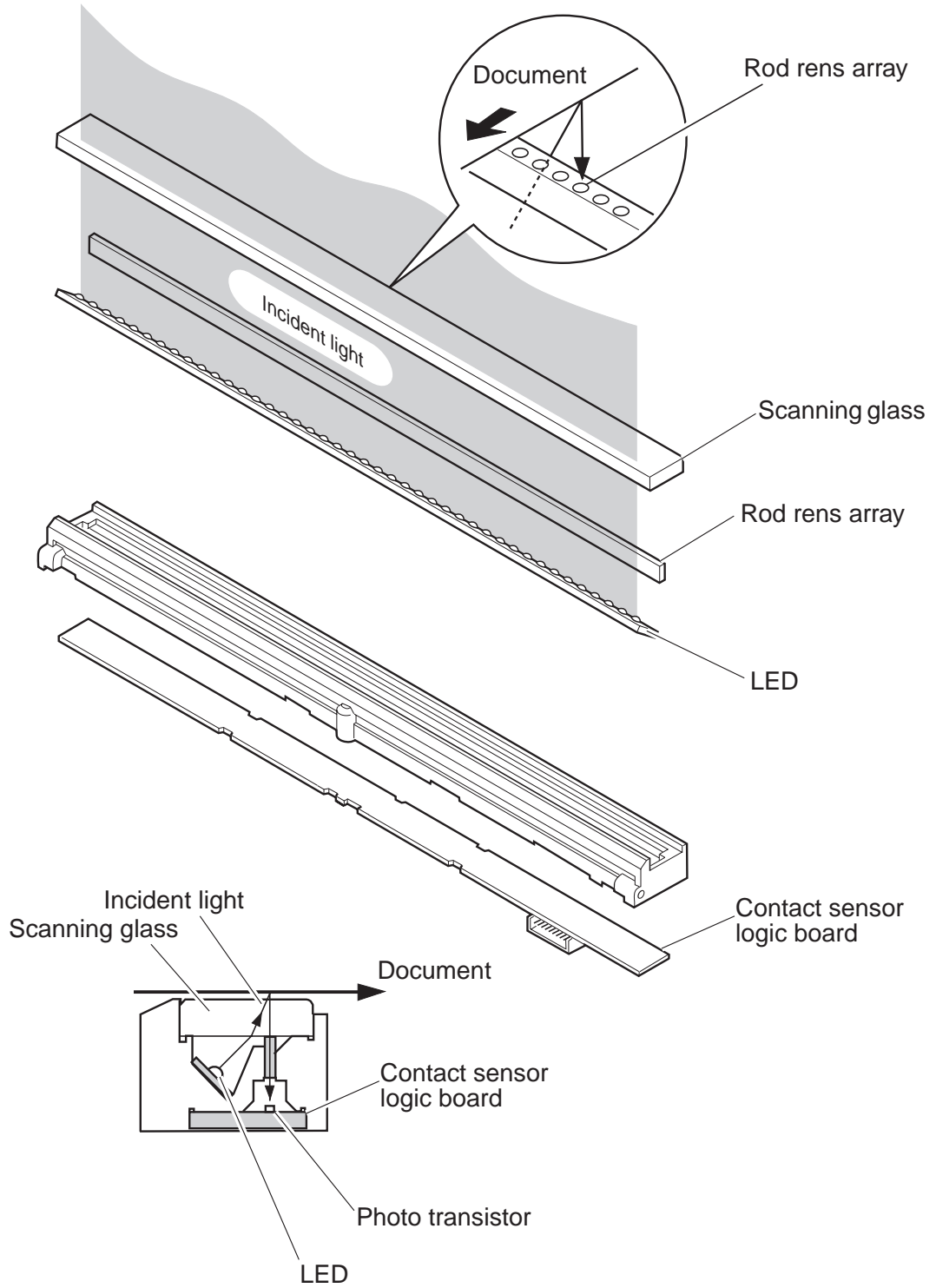

Figure 3-11 Contact Sensor

2.4 Paper Load Section

a) Functions

a-1) Recording paper pickup function

(From multi-purpose tray)

In case of paper pick-up from the multi-purpose tray, while the main motor rotates, the multi-purpose tray pick-up solenoid is turned ON. Then, the multi-purpose pick-up roller rotates, and a sheet of paper is fed into the printer section.

Up to 100 pages can be loaded into the multi-purpose tray at one time and the position of the movable paper guides can be adjusted for recording paper.

(From cassette 1)

In case of paper pick-up from the cassette, while the main motor rotates, the pick-up solenoid and feed roller clutch are turned ON. Then, cassette pick-up roller, cassette feed roller, separation roller and feed rollers rotate, and a sheet of paper is fed into the printer section.

(From cassette 2: Option)

The paper feeder is driven by the main motor of the fax via the gear.

When the nPRNT signal is sent to the ECNT board from the SCNT board, the main motor of the printer starts rotation. When the main motor reaches its prescribed speed, the paper feeder driver PCB receives the pick-up command from the ECNT board, and the paper feeder pick-up solenoid is turned ON. As a result, the pick-up roller, feed roller, and separation roller are driven by the main motor rotation.

a-2) Recording paper pickup jam detection function

When there is a recording paper pickup jam, this is detected by the recording pre-feed sensor.

a-3) No recording paper detection function

When there is no recording paper in the multi-purpose tray, this is detected by the multi-purpose tray paper sensor on the multi-purpose pickup assembly.

The cassette recording paper sensor in the feeder detects whether or not there is recording paper in the cassette.

a-4) Recording paper size and no cassette detection function

Cassette 1

The paper size in the cassette and whether the cassette is installed are detected by the three switches (SW600, 601, 602) on the paper size detection board 1.

Cassette 2 (Option)

The paper size in the cassette and whether the cassette is installed are detected by the three switches (SW800, 801, 802) on the paper size detection board 2.

b) Structures

b-1) Cassette paper loading

In case of paper pick-up from the cassette, while the main motor rotates, the pick-up solenoid (SL101) is turned ON. Then, cassette pick-up roller, cassette feed roller, separation roller and feed rollers rotate, and a sheet of paper is fed into the fax.

In case of paper pick-up from the multi-purpose tray, while the main motor rotates, the multi-purpose tray pick-up solenoid (SL102) is turned ON. Then, the multi-purpose pick-up roller rotates, and a sheet of paper is fed into the fax.



NOTE

Loading operations

a) Multi-purpose tray

When the ECNT board receives the nPRNT signal from the SCNT board, the printer starts the initial rotation. When the initial rotation ends (main motor warm-up, scanner motor warm-up, high-voltage control sequence, and fixing unit warm-up are completed), the multi-purpose tray pick-up solenoid (SL102) is turned ON.

As a result, the cam rotates, the lifter that paper is loaded is lifted, and the paper comes in contact with the multi-purpose tray pick-up roller. At the same time, the multi-purpose tray pick-up roller makes two rotations and a sheet of paper on the multi-purpose tray is picked up.

b) Cassette feeder

When the SCNT board inputs the nPRNT signal to the ECNT board, the main motor (M1) starts rotation. When the main motor reaches its prescribed speed, cassette pick-up solenoid (SL101) are turned ON. As a result, the cassette pick-up roller, cassette feed roller, separation roller and feed rollers are driven by the main motor rotation.

The cassette pick-up roller makes one rotation with the pick-up solenoid ON, and picks up the paper in the cassette. Then, the unnecessary sheets are removed by the separation roller and the picked up paper is fed to the pre-feed sensor (PS102).

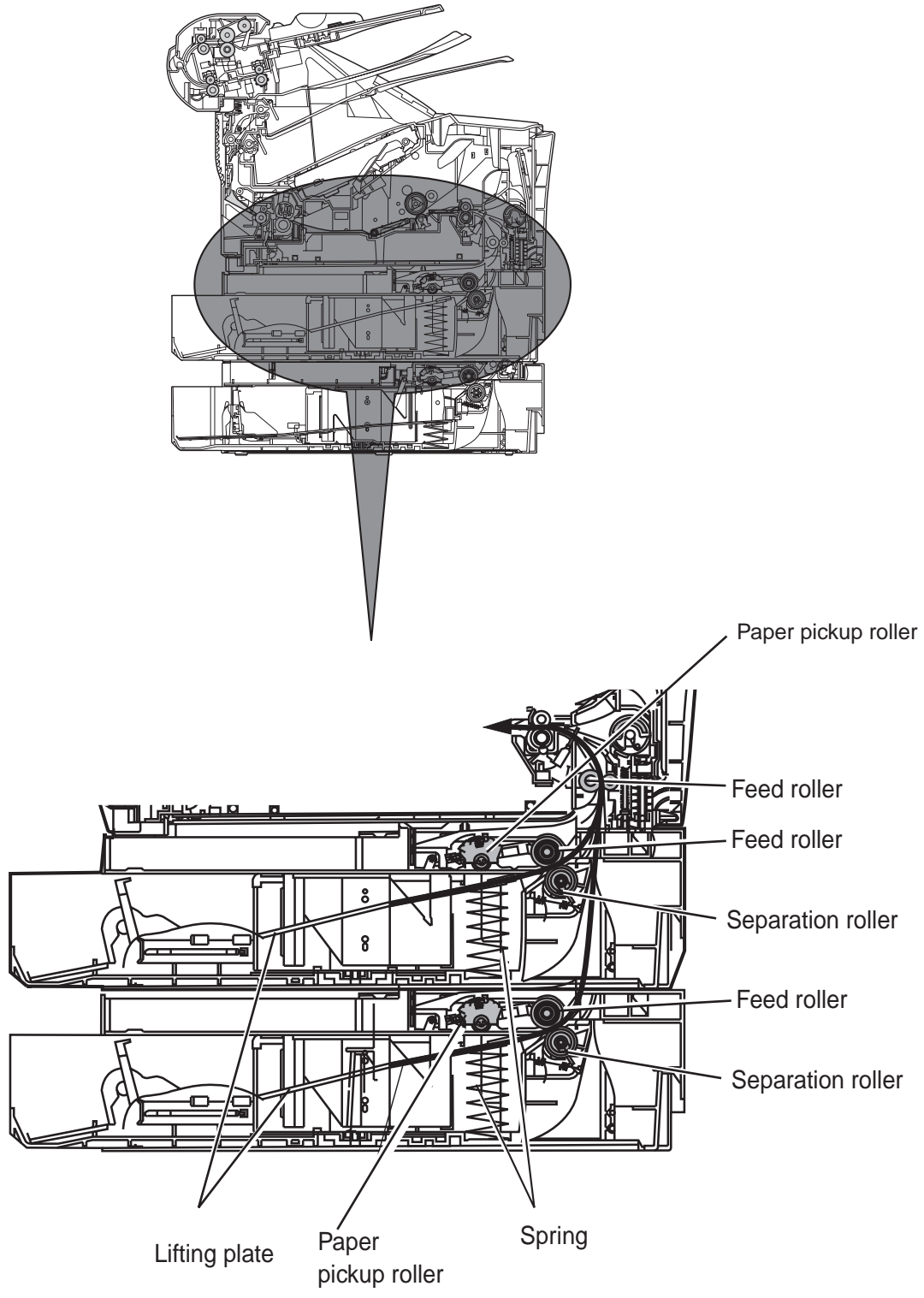

Figure 3-12 Cassette Paper Loading

b-2) Recording paper pickup jam detection configuration

Recording paper pickup jams are detected by the photo-interrupter type recording paper pickup sensor equipped with an actuator arm.

There are the following two types of recording paper pickup jams.

Recording paper pickup jam 1

a. When picking up paper from the cassette

The CPU assesses a pick-up delay jam if the pre-feed sensor (PS102) does not detect the leading edge of the paper within the prescribed period of time (T) after the paper was picked up.

In case the paper is picked up from the cassette: T= about 3.2 sec.

In case the paper is picked up from the paper feeder: T= about 4.6 sec.

b. When picking up paper from the multi-purpose tray or the envelope feeder

The CPU assesses a pick-up delay jam if the top of page sensor (PS103) does not detect the leading edge of the paper within the prescribed period of time (T) after the paper was picked up.

In case the paper is picked up from the multi-purpose tray: T= about 7.5 sec.

In case the paper is picked up from the envelope feeder: T= about 5 sec.

Recording paper pickup jam2

b. During paper feeding

The CPU assesses a pick-up stationary jam if the top of page sensor (PS103) does not detect the trailing edge of the paper within the prescribed period of time (about 4.4 sec.) after detecting the leading edge.



NOTE

Recording paper pickup jam processing

When a recording paper pickup jam occurs, the main motor drive is stopped, print operations are stopped, the error is displayed on the display, and the Rec. Paper lamp and Error lamp blink red.

For recording paper jams, "REC. PAPER JAM" is displayed on the display. If the error occurs during reception, the reception images are received into memory starting from the page during which the error occurred, but if the error occurs during copying, the copy image is erased.

If the top cover is opened during recording paper feed, this causes a recording paper jam.

b-3) No recording paper detection configuration

The presence of paper on the multi-purpose tray is detected by the multi-purpose tray paper sensor (PS105).



NOTE

No recording paper processing

When a no recording paper error occurs in the side cassette, the main motor drive is stopped, print operations are stopped, the error is displayed on the display, and the Rec. Paper lamp and the Error lamp blink red.

When a no recording paper error in the front cassette occurs, the main motor drive is stopped, print operations are stopped, the error is displayed on the display, the Rec. Paper lamp and the Error lamp blink red.

“SUPPLY REC. PAPER” is displayed on the display. If the error occurs during reception, the reception images are received into memory reception starting from the page during which the error occurred, but if the error occurs during copying, the copy image is erased.

b-4) Recording paper size and no cassette detection configuration

As there is no detection mechanism for paper size on the multi-purpose tray, the size of the paper set on the tray cannot be detected. The paper size in the cassette can be detected by the switches above. However, when using the universal cassette, the paper size is set by the user. If the setting made by the user is incorrect, it results in an incorrect detection.

Therefore, this printer has the top of page sensor (PS103) which detects the paper size by measuring the time from the leading edge passes the sensor until the trailing edge passes the sensor. If the detected size differs from that specified by the SCNT board or by the combination of the switches, the CPU assesses paper size mismatch and reports it to the SCNT board.

Paper size	SW601	SW602	SW603
No cassette	OFF	OFF	OFF
LEGAL	OFF	OFF	ON
LETTER	OFF	ON	ON
A4	ON	ON	ON

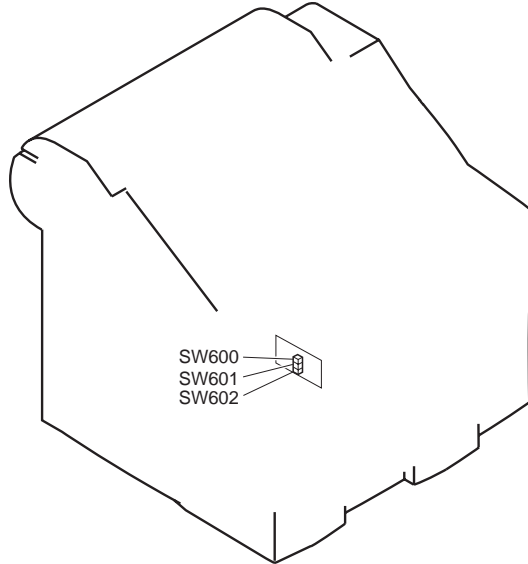

Figure 3-13 Paper Size Detection Configuration (Paper feeder)

Paper size	SW801	SW802	SW803	
No cassette	OFF	OFF	OFF	
LEGAL	OFF	OFF	ON	
Executive	OFF	ON	OFF	(Available for printer function.)
LETTER	OFF	ON	ON	
Other	ON	OFF	OFF	(Available for printer function.)
Custom	ON	OFF	ON	(Available for printer function.)
B5	ON	ON	OFF	(Available for printer function.)
A4	ON	ON	ON	

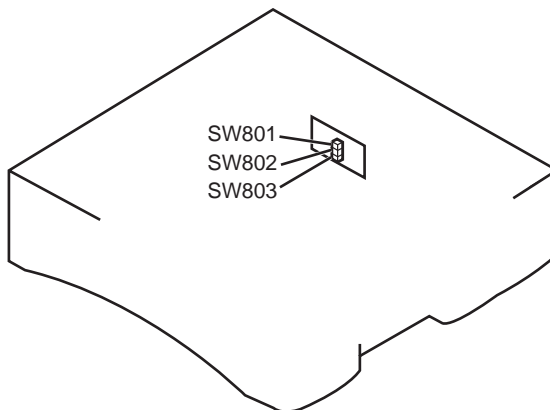

Figure 3-14 Paper Size Detection Configuration (Option paper feed unit PF-52)

2.5 Printer Section

The LASER beam printer engine comprises the following sections.

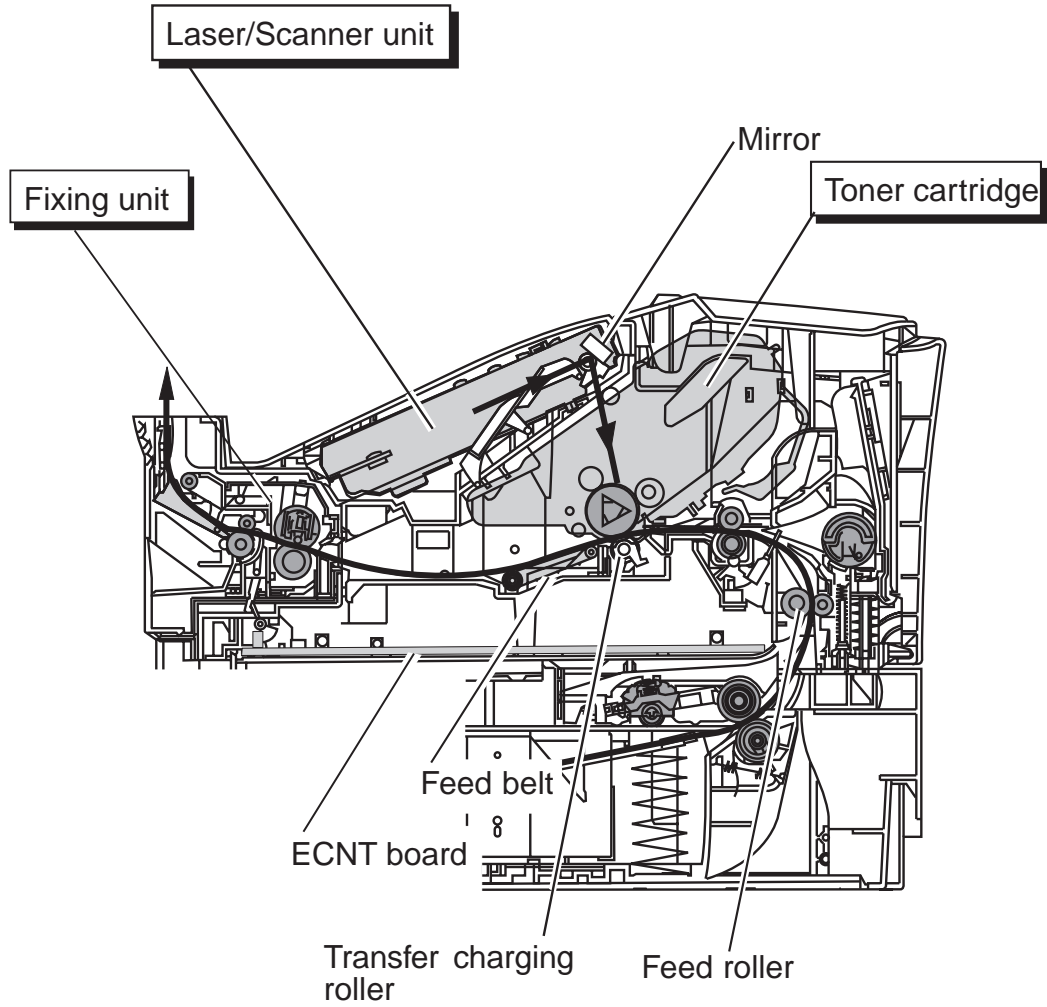

Figure 3-15 Printer Section

2.5.1 Paper feed/eject section

a) Functions

a-1) Paper feed/eject

The feed section feeds the recording paper fed from the pickup section to the toner transfer section and fixing unit. The eject section ejects the paper from the recording paper eject outlet on the main unit after printing.

a-2) Paper jam detection

Jams of the recording paper fed from the load section are detected by the recording paper eject sensor 1 and 2.

a-3) No-toner detection

The toner sensor (antenna method) inside the toner cartridge detects toner in the cartridge.

b) Structure

b-1) Paper feed

The recording paper is fed to the toner transfer section by the recording paper feed roller which is driven by gears with power from the main motor.

The recording paper feed is controlled by the ECNT board CPU counting the main motor and the photo-interruptor type pre-feed sensor, top of page sensor, recording paper eject sensor 1 and 2, which are equipped with actuator arms detecting the recording paper feed status.

After fixing, the recording paper is ejected by the paper feed roller and face-down delivery roller driven by gears with power from the main motor through the recording paper eject outlet on the main unit and accumulated in the order printed.



NOTE

Start of printing

When the paper reaches the pre-transfer roller after passing through the pre-feed sensor (PS102), its skew is adjusted by hitting the registration arm.

In the prescribed period of time after the top of page sensor (PS103) detects the leading edge of the paper, the VERTICAL SYNC signal (nTOP) is sent from the ECNT board to the SCNT board.

As the paper is fed during this time, the leading edge of the image on the drum matches the leading edge of the paper by sending the nVDO signal in a certain period of time after the video controller receives the nTOP signal. The paper goes through transfer, separation, fixing, and delivery unit and is delivered onto the face-up or face-down tray.

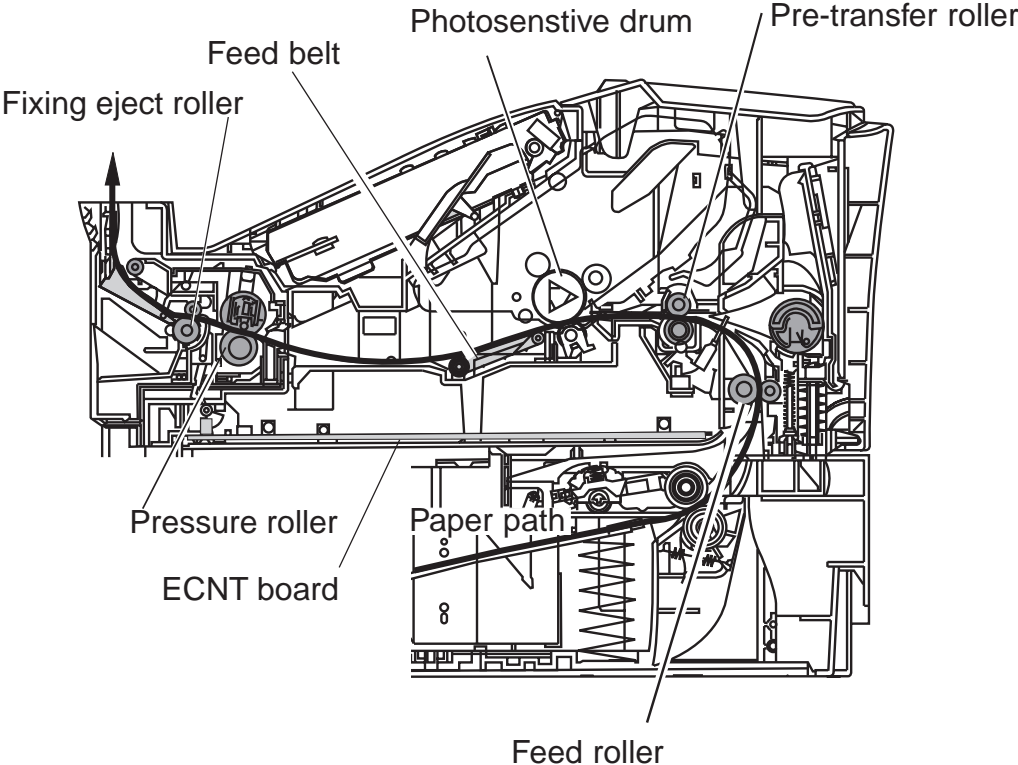

Figure 3-16 Paper Feed/Eject Section

b-2) Recording paper jam detection configuration

Recording paper jams in the paper feed/eject section are detected by the photo-interrupter type pre-feed sensor, top of page sensor, recording paper eject sensor 1 and 2, which is equipped with an actuator arm.

The CPU assesses a delivery delay jam if the recording paper eject sensor 1 (PS501) does not detect the leading edge of the paper within the specified period of time (T) after the top of page sensor (PS103) detects the leading edge of the paper.

- For paper 200mm or more: T= about 3.2 sec.
- For paper less than 200mm: T= about 5.7 sec.

Recording paper eject jam

A “recording paper eject jam” means that the recording paper eject sensor cannot detect the trailing edge even 3.0 to 6.0 seconds after the top of page sensor detects the trailing edge.



NOTE

Recording paper jam detection processing

When a recording paper jam occurs, the main motor drive is stopped, print operations are stopped, the error is displayed on the display, and the Rec. Paper lamp and the Error lamp blink red. Also, if the printer cover is opened during recording paper feed, this is treated as a recording paper jam.

“REC. PAPER JAM” is displayed on the display.

If the jam occurs during reception, the reception images are received into memory reception starting from the page during which the recording paper jam occurred, but if the jam occurs during copying, the copy image data are erased.

b-3) Toner level detection/cartridge detection

The FX 6 toner cartridge has a toner sensor.

The circuit compares the output value of the developing AC bias and the output value (ANT) from the antenna inside the cartridge, and outputs the toner detection signal.

The CPU detects the toner level and whether the cartridge is installed or not when the developing AC bias is applied to the developing cylinder. The toner level is always detected when the developing AC bias is applied, and the cartridge is detected only when the developing AC bias is applied during the initial rotation.

2.5.2 LASER/Scanner section

a) Functions

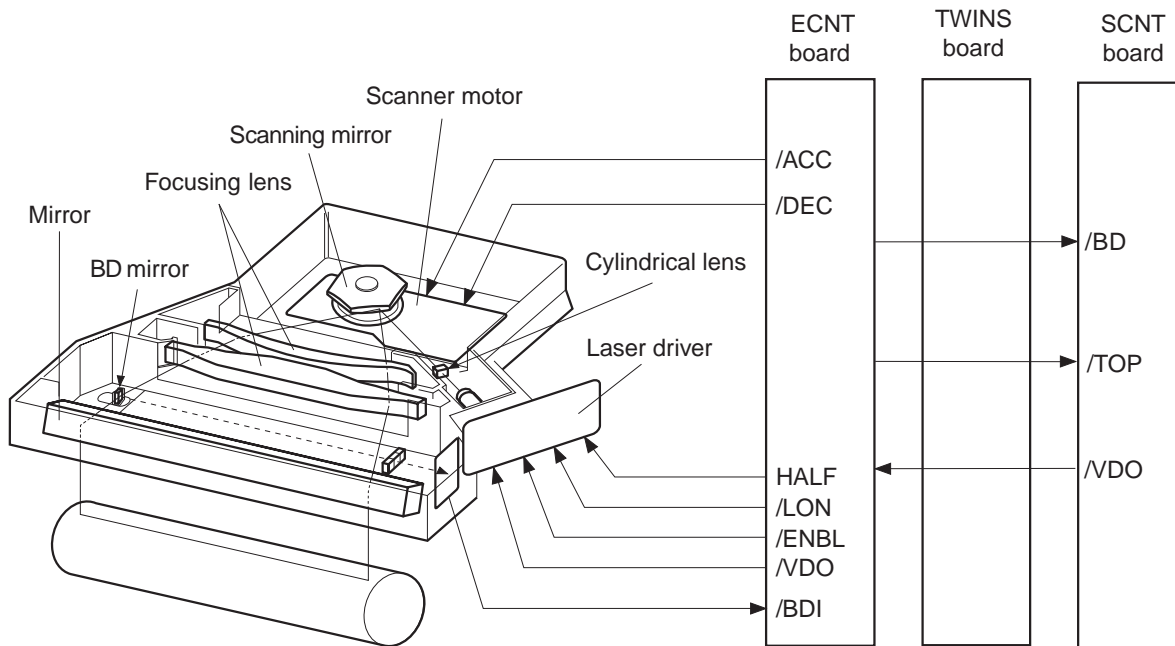

Figure 3-17 LASER/Scanner Section

The VIDEO signal (nVDO) is sent from the SCNT board to the laser driver of the laser/scanner unit through the TWINS board and ECNT board.

The laser driver turns the laser diode ON and OFF according to the nVDO signal and generates the modulated laser beam only when the VIDEO DATA ENABLE (nENBL) signal from the ECNT board is "L."

The modulated laser beam is aligned by a collimator lens and a cylindrical lens into a parallel beam. It then strikes the scanning mirror which is rotating at a constant speed.

The beam reflected from the scanning mirror is brought to a point of focus on the photosensitive drum by the focusing lens and mirror.

As the scanning mirror rotates at a constant speed, the beam is scanned across the drum at a constant speed.

The photosensitive drum also rotates at a constant speed allowing the laser beam to form an image on the drum surface.

b) Automatic power control of laser diode

The laser driver IC conducts the automatic power control (APC) of the laser diode so that the laser diode emits a beam of constant intensity.

When the FORCED LASER ON signal (nLON) becomes “L,” or the VIDEO DATA ENABLE signal (nENBL) and nVDO signal become “L,” the laser diode emits light according to the standard voltage of laser driver PCB. The photo diode in the laser diode detects the beam intensity and feeds back the corresponding current value to the control amplification circuit. It is then compared with the current value set by the power adjustment circuit, and the intensity of the current to the laser diode is controlled.

c) Horizontal synchronization control

The CPU generates an unblanking signal inside the IC501 based on the BD INPUT signal (nBDI) sent from the BD PCB of the laser/scanner unit.

IC501 sets the FORCED LASER ON signal (nLON) to “L” during unblanking period. The laser driver turns the laser diode ON when the nLON signal is “L.”

The laser beam turned on by the nLON signal is reflected at the small fixed BD mirror located in the light path where the laser beam scanning starts, and is input to the BD PCB in the laser/scanner unit.

The BD PCB detects the laser beam, generates a BD INPUT signal (nBDI), and sends it to the CPU. The CPU generates the HORIZONTAL SYNC signal (nBD) according to the nBDI signal and sends it to the SCNT board.

2.5.3 Toner cartridge

a) Functions

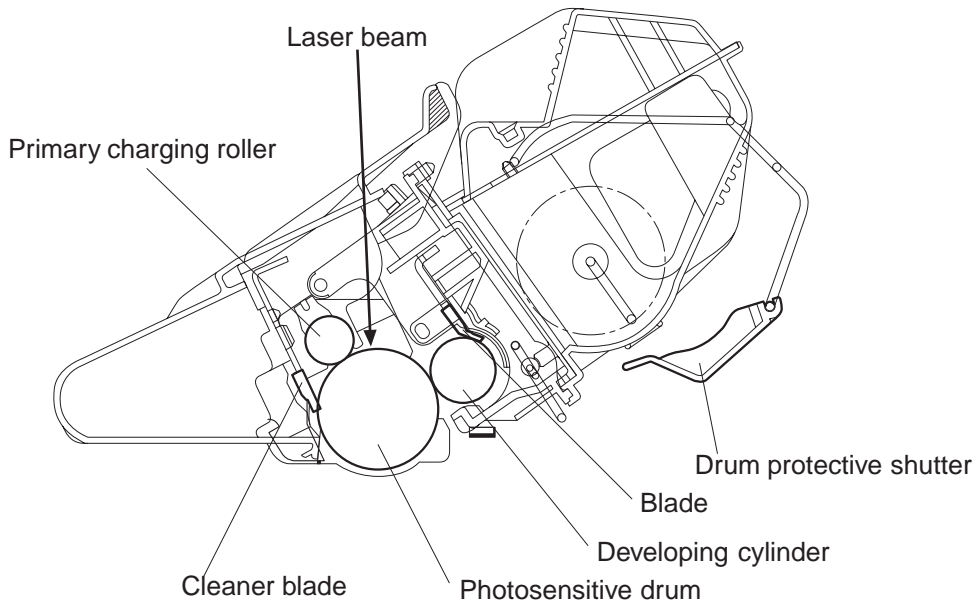

Figure 3-18 Toner Cartridge

The image formation system is the central hub of the fax, and consists of the photosensitive drum, developing unit, charging rollers, etc.

When the PRINT signal (nPRNT) is sent from the SCNT board to the ECNT board, the ECNT board drives the main motor to rotate the photosensitive drum, developing cylinder, primary charging roller, and transfer charging roller.

The primary charging roller uniformly applies negative charges on the surface of the photosensitive drum. To form a latent image on the photosensitive drum, the laser beam modulated by the nVDO signal is exposed onto the photosensitive drum surface.

The latent image formed on the photosensitive drum is changed to a visible image by the toner on the developing cylinder, then transferred onto paper by the transfer charging roller. Residual toner on the photosensitive drum surface is scraped off by the cleaning blade. The potential on the drum is made uniform by the primary charging roller in preparation for the next latent image.

The cartridge has a toner sensor that detects the toner level and no cartridge.

If the toner in the cartridge becomes lower than the prescribed level or there is no cartridge installed in the fax, the CPU notifies such information to the SCNT board.

b) Electrostatic latent image formation block

This block follows two steps to produce an electrostatic latent image on the photosensitive drum.

When “Laser beam exposure” of this block is completed, negative charge remains in the unexposed “dark” areas; however, those in the exposed “light” areas are eliminated.

This image of negative charges on the drum is invisible to the human eye, so it is called an “electrostatic latent image.”

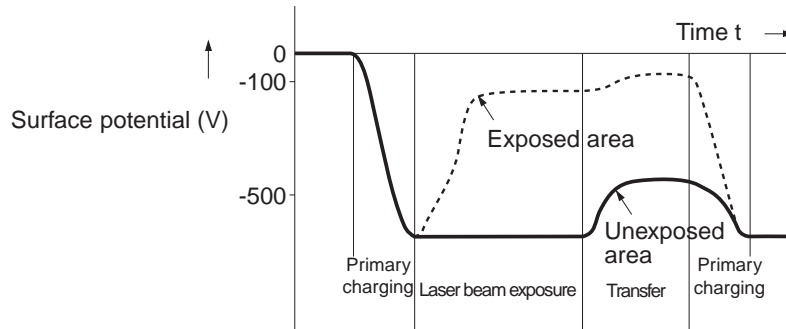

Figure 3-19 Surface Potential

b-1) Primary charging

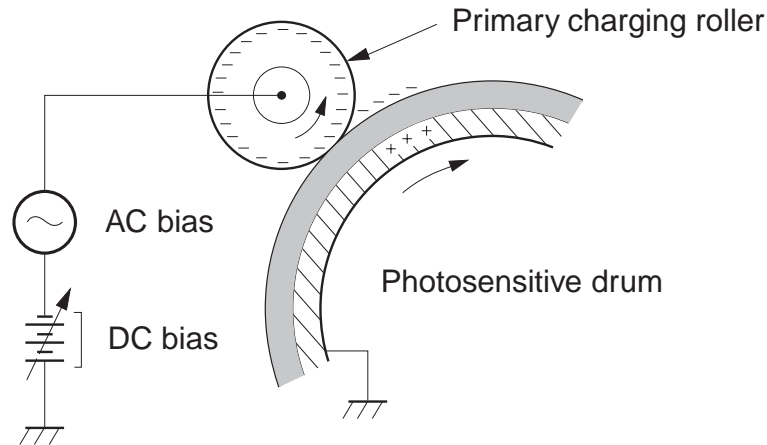

Figure 3-20 Primary Charging

In preparation for the latent image formation, a uniform negative potential is applied to the photosensitive drum surface. For primary charging, the printer uses the charging method, which directly charges the drum.

The primary charging roller is made of conductive rubber. In addition to DC bias, AC bias is also applied to the primary charging roller to keep the potential on the drum surface uniform. The DC bias changes with the developing DC bias.

b-2) Laser beam exposure

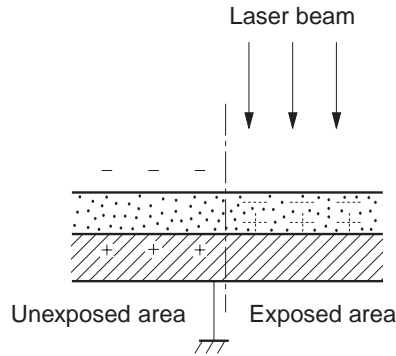

Figure 3-21 Laser Beam Exposure

When the laser beam scans the drum surface, it causes the charges in the areas struck by the laser beam to be neutralized. These areas on the drum surface form the electrostatic latent image.

c) Developing block

Particles of toner are placed onto the electrostatic latent image on the surface of the drum to form a visible image. This fax uses the toner projection development method with a single-component toner.

c-1) Developing

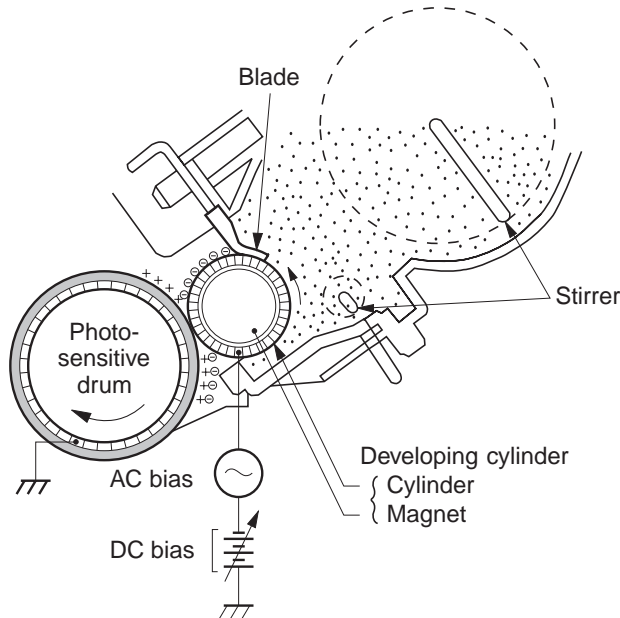
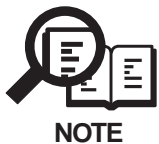

Figure 3-22 Developing



Charges in the exposed areas of the photosensitive drum are shown as positive in this figure, even though they are actually negative. It means that the photosensitive drum potential is higher as compared with that of cylinder.

As shown in Figure 3-23, the developing unit consists of a fixed magnet, a developing cylinder and a rubber blade. The developing cylinder rotates around the fixed magnet.

The single-component toner consists of magnetite and a resin binder, and is held to the cylinder by magnetic attraction. The toner functions as an insulator, and is charged negative by the friction with the rotating cylinder.

The areas on the drum that were exposed to the laser beam have a higher potential than the negatively charged toner particles on the developing cylinder. When these areas approach the toner layer of the cylinder (with negative charges), the potential difference (higher on the drum) projects the toner particles to them.

This is called toner projection, which makes the latent image on the drum visible.

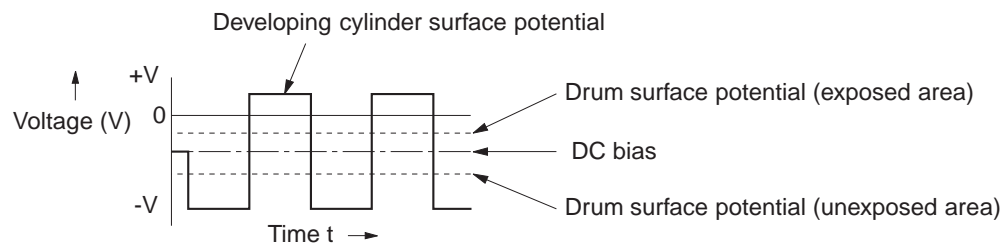

Figure 3-23 Developing Cylinder/Drum Surface Potential

An AC bias is applied to the developing cylinder to help project the toner particles to the drum surface and improve the contrast of the printed image. The center voltage of the AC bias (1600 Vp-p) varies with the DC bias voltage. The changes in the DC bias change the potential difference between the cylinder and drum so that the density of the print can be adjusted. The adjustment is made through a command from an external device.

This fax has a stirring mechanism in the cartridge to ensure that the toner is applied smoothly to the cylinder.

d) Drum cleaning block

In the transfer block, not all the toner is transferred to the paper, but some remains on the photosensitive drum.

In this block, the residual toner is cleaned so that the next print image will be clear and distinct.

d-1) Drum cleaning

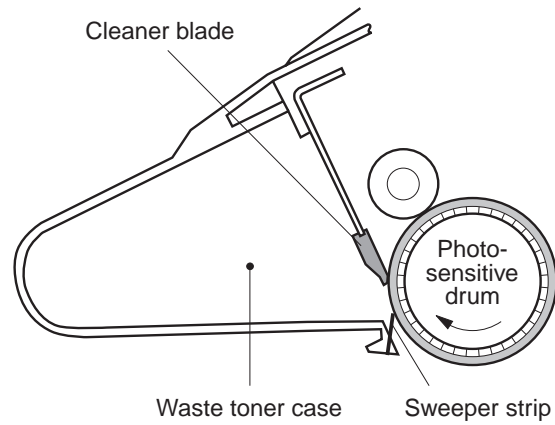

Figure 3-24 Drum Cleaning

The residual toner on the drum surface is scraped away with the cleaner blade to clean the drum surface in preparation for the next print. The removed waste toner is collected into the waste toner case.

- The high-voltage terminal of the toner cartridge is shown below.

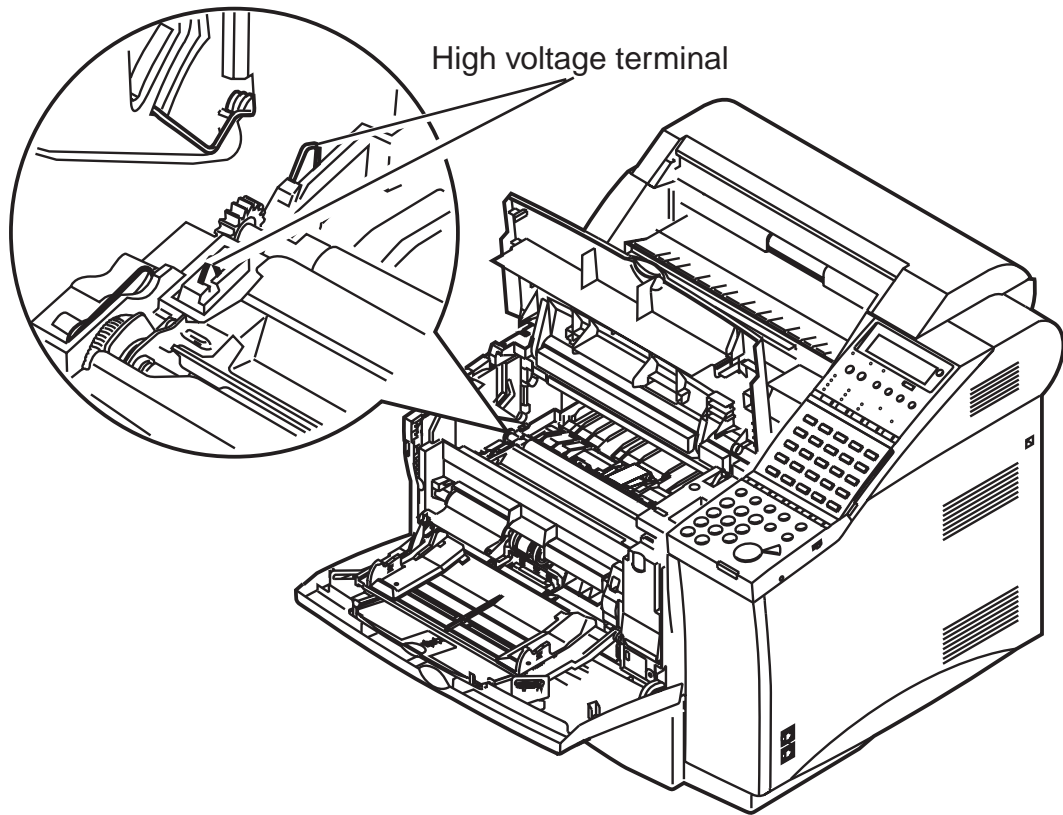

Figure 3-25 High Voltage Terminals

- The AC bias applied to the developing cylinder during development is about 1600 Vp-p.
- The DC bias applied to the developing cylinder during development changes with “SELECT DENSITY” set in the user data.

2.5.4 Transfer/Separation section

In this block, the toner image is transferred from the drum surface to the paper.

a) Transfer

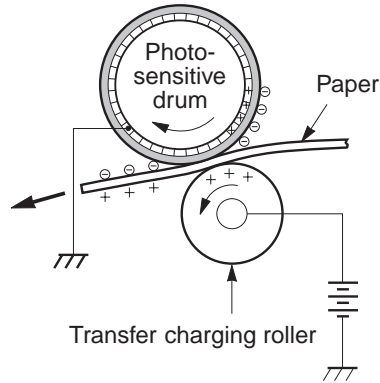

Figure 3-26 Transfer

Positive charges are applied to the back of the paper to attract the negatively charged toner particles to the paper.

Roller transfer method is applied to stabilize the paper feed and to reduce ozone generation.

b) Separation

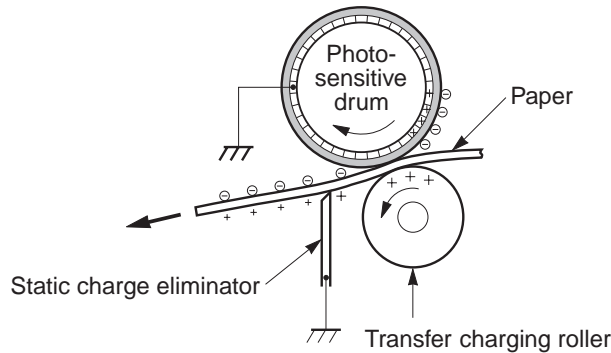

Figure 3-27 Separation

The elasticity of the paper causes it to separate from the drum.

To stabilize the paper feed system and to prevent droplets on the printed image at low temperature and low humidity, the charge on the back of the paper is reduced by the static charge eliminator.

2.5.5 Fixing section

As the toner image transferred onto the paper in the transfer block is only adhered by electrostatic attraction, even a light touch will smear the image.

In the fixing block, the toner image is fixed by applying heat and pressure to the paper and the toner. This fuses the toner particles onto the paper to create permanent image.

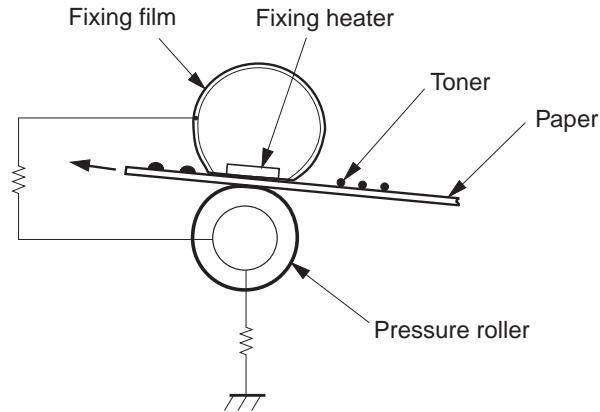

Figure 3-28 Fixing section

This printer utilizes an on-demand method which uses fixing film with small heat capacity. This method has fast temperature rising time and it is not necessary to supply power to the fixing heater during the standby mode. Wait time is shortened and energy conservation is made possible by this method.

Fixing film is cylindrical film of polyimide. Its surface is coated with fluorine to prevent offset.

- This fax machine does not have "-ACVIN signal".
- If the ECNT board CPU detects with the thermistor that the fixing heater temperature is over 428°F (220°C), it cuts off the power to the fixing heater (Software protection).
- If the ECNT board fixing heater protective circuit detects that the fixing heater temperature is 464°F (240°C), it cuts off the power to the fixing heater regardless of the ECNT board CPU output (Hardware protection).
- If the fixing heater temperature is over 446°F (230°C), the thermal fuse in the fixing film unit blows, turning the fixing heater off.
- The ECNT board CPU detects thermistor broken wire in the following cases, and assesses warm-up error or abnormally low temperature.
 1. The thermistor, in the low-temperature detection mode, does not exceed about 68°F(20°C) within about 0.7 seconds after the heater is turned ON.
 2. The thermistor, in the high-temperature detection mode, does not exceed about 122°F(50°C) within about 5.0 seconds after the heater is turned ON.
 3. The thermistor, in the high-temperature detection mode, detects over about 122°F(50°C) after the heater is turned ON. Then the output voltage from the thermistor is more than about 3.4V for more than about 100ms continuously.
- The ECNT board CPU detects heater broken wire in the following cases and assesses warm-up error or abnormally low temperature.
 1. The thermistor, in the low-temperature detection mode, does not rise +50°F(+10°C) from the initial temperature within about 2.5 seconds after the heater is turned ON.
 2. The thermistor, in the low-temperature detection mode, does not rise +68°F(+20°C) from the initial temperature within about 2.5 seconds after rising +50°F(+10°C) from the initial temperature since the heater is turned ON.
 3. The thermistor, in the high temperature detection mode, does not exceed about 320°F(160°C) within about 20 seconds after rising +68°F(+20°C) from the initial temperature since the heater is turned ON.
 4. When the thermistor is in the high temperature detection mode and the initial temperature is 185°F(85°C) or below, the temperature does not exceed about 320°F(160°C) within about 20 seconds after the heater is turned ON.

5. When the thermistor is in the high temperature detection mode and the initial temperature is 185°F(85°C) or more, it does not exceed about 320°F(160°C) (about 284°F(140°C) in case of 1200DPI) within about 6 seconds after the heater is turned ON.
6. During print temperature control, the condition of below about 302°F(150°C) (about 266°F(130°C) in case of 1200DPI) lasts for more than about 1 second continuously.

2.6 Circuit Overview

2.6.1 SCNT board function block diagram

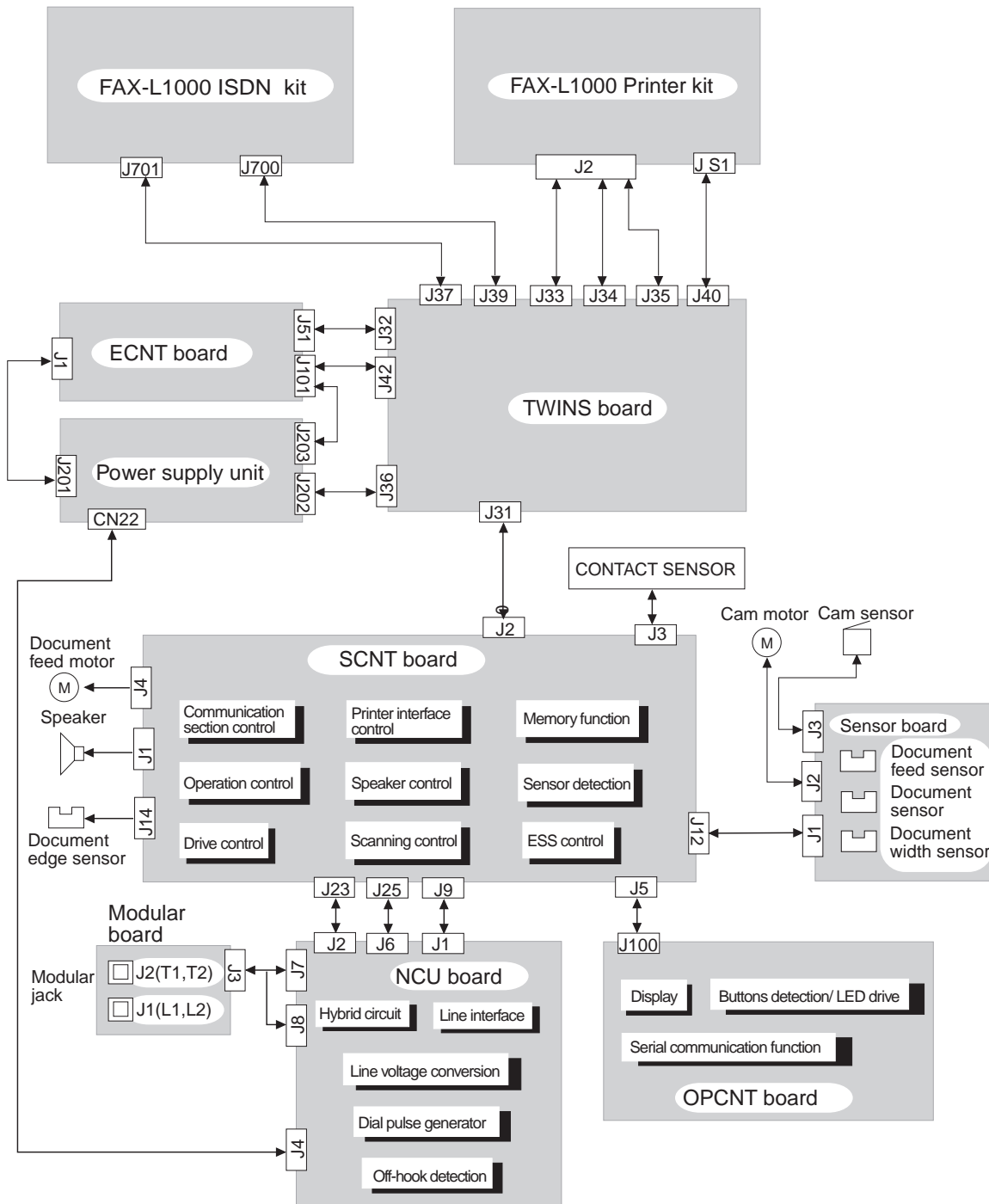

Figure 3-29 Function Block Diagram (1)

2.6.2 Functions

a) SCNT board

The SCNT board performs the following functions.

Drive control

The drive control section controls the document feed motor in the document scanning section.

Operation panel control

The operation panel control section serially transfers data to or from the control IC on the OPCNT board, receives button operation status, document status, etc., and sends the display and LED signals to the control IC on OPCNT board.

Scanner control

Image data input from the contact sensor are processed by the UHQ-6.6 image processing IC, coded by the CODEC IC, and sent to the DRAM from the system controller.

Printer interface control

The printer control section converts facsimile data of horizontal resolution of 8 or 16 dots/mm, and vertical resolution of 3.85, 7.7 or 15.4 line/mm to LBP print data of 600 dpi. This section synchronizes the vertical sync signal (nTOP) to the printer section with the horizontal sync signal (nBD) from the printer section to transmit an image signal (nVDO) to the printer section.

Communications unit control

The SCNT board detects line signals, such as CNG, DTMF and ROT. The modem, with a transmission rate of 33.6k bps, modulates and demodulates transmission/reception data and sends DTMF signals.

Speaker control

The SCNT board controls the alarm, button operation tones and line monitor tones.



NOTE

The speaker volume control on the operation panel adjusts the line monitor volume. The button operation and alarm volumes are adjusted by specifying user data.

Sensor detection

The SCNT board detects the statuses of the sensors which in the scanner section, printer section, paper loading section, and covers to monitor the drive section.

Memory functions

User data, service data, data registered before shipment from the factory, and communications management information, are stored to the SRAM. Image data are stored to the DRAM.

Memory backup

The SCNT board is provided with a function for backing up data in control/image processing memory (SRAM) and image storage memory (DRAM) by lithium battery, and rechargeable battery, even if a power interruption occurs, or the power cord is disconnected by accident.

ESS (Energy Save Standby) control

The SCNT board controls the ESS function which reduces power consumption when the main unit is at standby.

b) NCU board

The NCU board performs the following functions.

Hybrid circuit

Signals sent from the system controller to the telephone line are prevented from entering the reception circuit.

Dial pulse generator

The dial pulse generator generates a dial pulse to send a dial signal from the fax through the dial line by turning the relay on and off using the control signal from the SCNT board.

Off-hook detection circuit

Detects the off hook state from the DC current flowing to the circuit, when the extension telephone (or option handset) is off hook.

Line voltage conversion circuit

The line primary on the NCU board is controlled by a +48 V DC line voltage, therefore, the line voltage conversion transformer converts the voltage of the control TTL for the lone secondary.

c) Modular board

Line interface

Signals from the two modular jacks for the telephone line and extension telephone (or option handset), are transferred to the line voltage conversion circuit on the NCU board and the signals from the fax are transferred to the telephone line.

d) OPCNT board

Buttons detection and LED drive function

The control IC on the OPCNT board detects the buttons operation status, and drives the LCD and LEDs.

Display

The control IC in the LCD module controls the 20-column × 2-line LCD according to the display signals from the SCNT board.

Serial communication

Serial communication with the SCNT board is used to send buttons, speaker volume switch, document status, etc., and to receive display, LED drive data, etc..

Sensors

The signals detected by the one touch dial cover sensors are sent to the SCNT board via the control IC on the OPCNT board.

e) Sensor board

Sensors

The document sensor, document width sensor, and document feed sensor are attached to the paper sensor board. The signals detected by these sensors are sent to the SCNT board.

2.6.3 ECNT board function block diagram

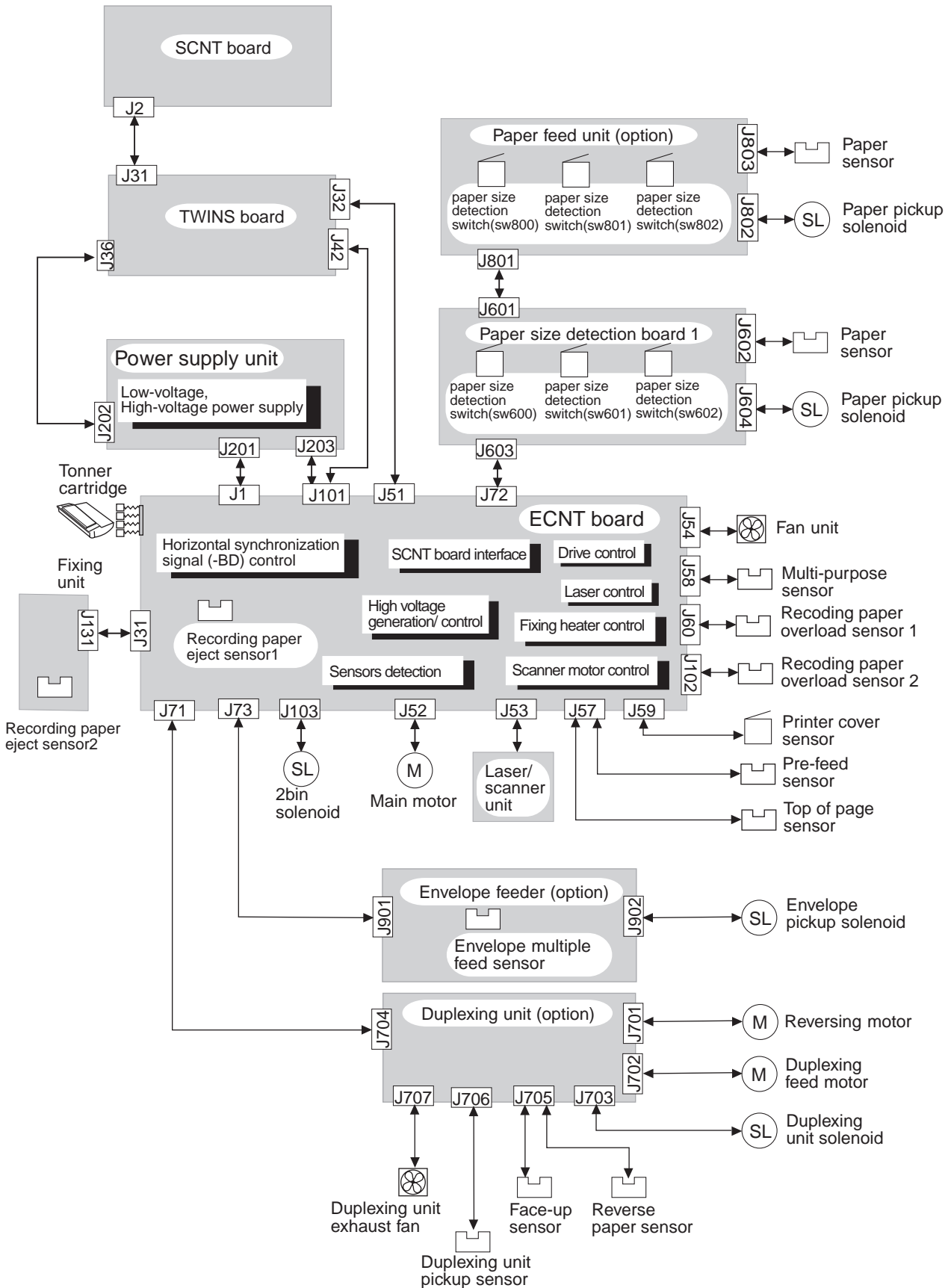

Figure 3-30 Function Block Diagram (2)

2.6.4 Functions

a) ECNT board

Fixing heater control

The fixing heater control section monitors the DC voltage supplied from the power supply in response to the AC 187~264 V, and the fixing heater thermistor, and drives the heater so that the temperature reaches the specified level. If the heater temperature is judged to be abnormal, the power supply to the heater is shut off.

High voltage generation/ control

The high voltage control section is to control the high voltage applied to the toner cartridge primary charge roller and developing cylinder, and the transfer charging roller of the toner transfer section.

Drive control

The drive control section controls the main motor, paper pickup solenoid, and fan. Also, the FANTAC signal from the fan via the power supply unit is detected, and the fan rotation monitored.

Sensors detection

The ECNT board monitors the drive section by detecting the statuses of the sensors in the printer section and paper pickup section.

SCNT board interface

The SCNT board interface section serially transmits the horizontal synchronization signal (nBD) and the vertical synchronization signal (nTOP) to the SCNT board, and, in turn, receives serially transmitted command signals from the SCNT board, and returns status signals, in order to inform the SCNT board of the printer section status.

Laser control

The laser control section controls the drive of the laser diode in the laser/ scanner unit, in response to print data from the SCNT board. It also the laser diode auto power check, performed on each line of print data.

Horizontal synchronization signal control

When the laser beam reaches the horizontal printing start position, the horizontal position detection signal (nBDI) from the laser laser/scanner unit is detected, and the horizontal synchronization signal (nBD) sent to the SCNT board. Also, the output frequency status of the horizontal synchronization signal (nBD) is monitored.

Scanner motor control

The scanner motor drive is controlled so that the print image vertical resolution reaches 600 dpi. Also, the SCNTAC signal from the laser/scanner unit is detected, and the scanner motor rotation status monitored.

Toner detection

Signals are received from the antenna type toner sensor, and monitors the remaining toner of the toner cartridge.

b) Paper size detection board 1

Sensors

The cassette recording paper size sensor (SW600,601,602), and cassette recording paper sensor for cassette1 are attached to the paper size detection board 1. The signals detected by these sensors are sent to the ECNT board.

c) Paper size detection board 2

Sensors

The cassette recording paper size sensor (SW800,801,802), and cassette recording paper sensor for cassette2 are attached to the paper size detection board 2. The signals detected by these sensors are sent to the ECNT board.

d) Power supply

Switching regulator

This fax generates +24V, +12V and +3.3V from the 230V household current power supply, and supplies these voltages to the respective sections.

2.6.5 SCNT board component block diagram

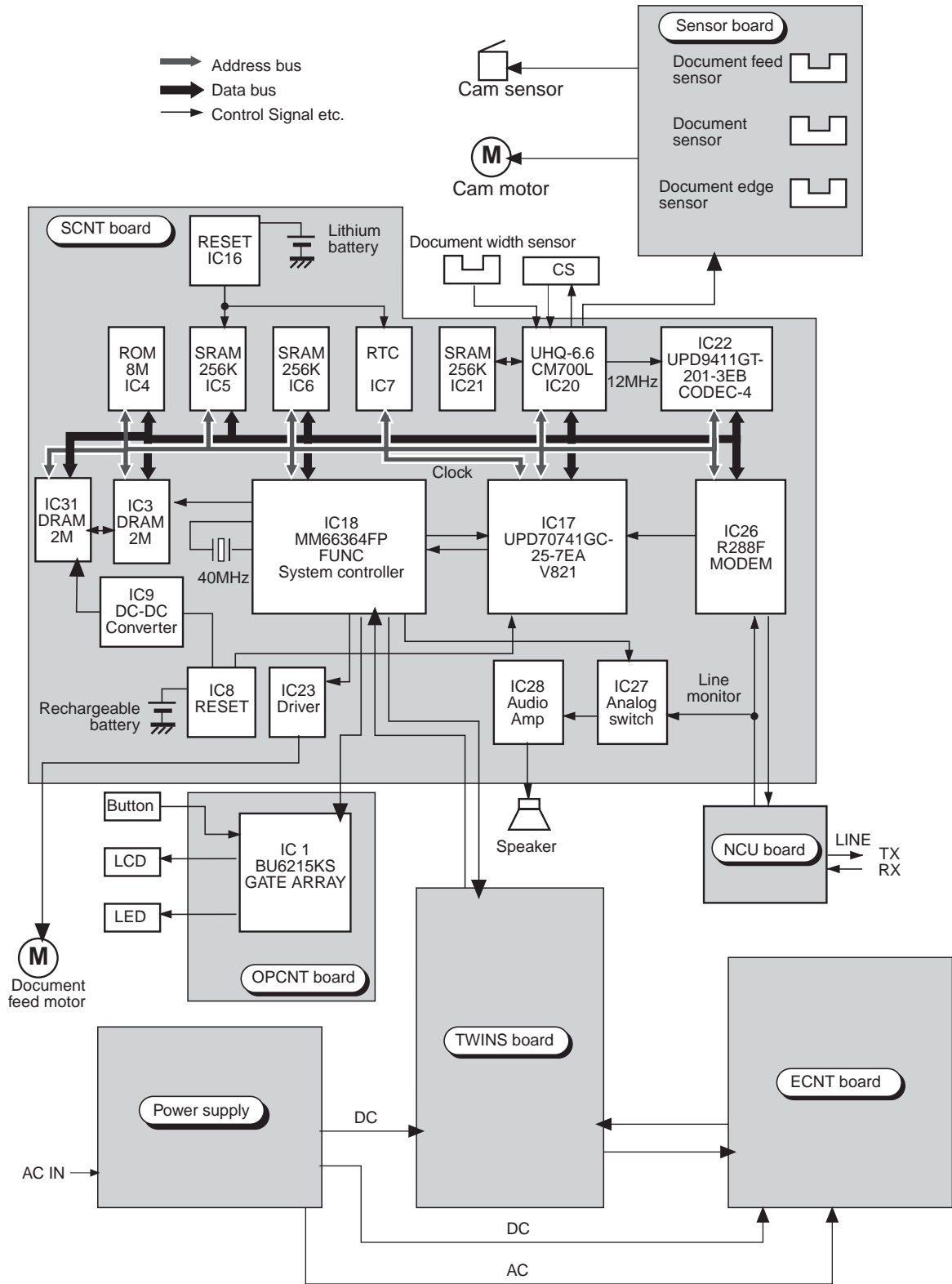

Figure 3-31 Component Block Diagram (1)

a) System control section (SCNT board)

The system control section consists of the following components and controls the entire facsimile system.

a-1) MPU (Micro Processor Unit) (IC 17)

The MPU, on NEC UPD70741GC-25-7EA, has the following main functions.

- 16-bit CPU
- 24-bit address bus
- 16-bit data bus
- Software CODEC
- Interrupt control unit

The CPU controls interrupts from the system controller IC, and the others the inside.

- CSI (Clocked Serial Interface)

a-2) System controller (IC 18)

The system controller is a gate array for controlling MPU peripheral devices.

The main functions of the system controller are as follows:

- DMA controller
 - DMA interface
 - DRAM controller
 - ESS control
 - Chip select
 - NMI generator
- Generate NMI for ESS mode cancellation (cancellation in CPU stop mode)
- CI pulse width counter
 - Timer

Used to generate dial pulses

- Clock divider
- Generate basic clocks (16 MHz) for codec IC (IC22)
- CPU interface
 - CODEC interface
 - UHQ-6.6 interface
 - Row to column converter
- Specify the DRAM address
- R.T.P.
- Fine adjust the motor speed during high speed scanning in Ultra Fine or Super Fine mode
- 16-bit serial interface
- Serial interface to gate array on the operation panel

a-3) EP-ROM (IC 4)

The 8-Mbit EP-ROM contains the control program for the operation section, read section, and communication control section of the fax.

a-4) DRAM (IC 3, 31)

This 16-Mbit DRAM is backed up by rechargeable battery (approx. 12 hour after AC power interruption), and is used as memory for storing image data and MPU work area.

a-5) SRAM (IC 5, 6)

These 256-kbit SRAMs are backed up by lithium battery. SRAM holds data registered for system control and communications management information.

a-6) RTC (Real Time Clock) IC (IC 7)

A Seiko epon RTC-63421A is used as the RTC. The RTC IC is backed up by lithium battery, and counts the date and time.

b) Document scanning section (SCNT board)

The document scanning section consists of the following components and processes scanning image data.

b-1) Image processing IC (IC 20)

The main functions of the image processing IC (UHQ-6.6) are as follows:

•A/D conversion

Input signals from the contact sensor are A/D converted

•ABC (Auto Background Control)

•AGC (Auto Gain Control)

•Read density - document density conversion

•Edge enhancement processing

•Binarization processing

•Notch eliminate processing

•Autohalf-tone processing

•Error diffusion processing

•Parallel/Serial conversion

•Dark correction

Adjust variations in the output of transistor array chips when the LED is turned off

•Shading correction

•Contact sensor interface

•SRAM interface

b-2) CODEC IC (IC 22)

The main functions of the CODEC IC are as follows:

- Scanner interface
Serial interface to image processing IC
- Encoder
- Decoder
- Printer interface
Serial interface port for the SCNT printer interface

b-3) SRAM (IC 21)

A 256-kbit SRAM is used as a buffer for the image processing data.

c) Communication control section (SCNT board)

The communication control section consists of the following components and controls facsimile communication.

c-1) MODEM IC (IC 26)

A Context R288F is used as the modem IC. The MODEM IC carries out G3 modulation conforming to ITU-T standards V.34, V.33, V.17, V.29, V.27ter and V.21 on transmitted data received from the MPU during transmission. During reception, the MODEM IC carries out G3 modulation on received signals from the telephone line, according to the same standards.

d) Printer interface section (SCNT board)

The printer interface section consists of the following components and controls the printer section by conversion data from the system control section into print data and printer control commands.

d-1) System controller (IC 18)

The system controller has the following printing system image processing function.

- LBP video interface
- Line buffer control
- Smoothing processing
- Reduction processing
- WPD (Window Pattern Diffusion)
Eliminate image defects when an image is reduced by the error diffusion method

2.6.6 ECNT board component block diagram

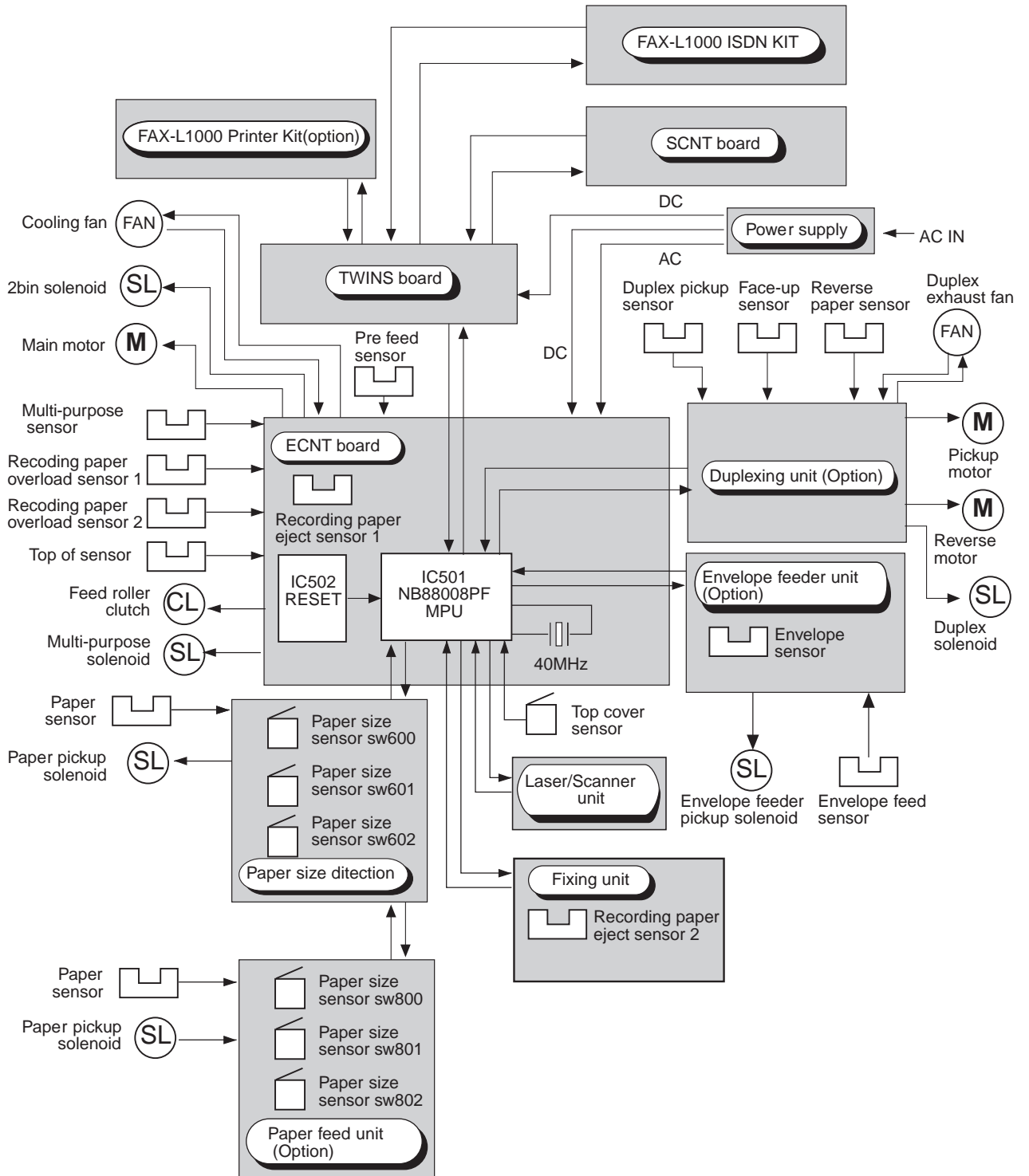

Figure 3-32 Component Block Diagram (2)

a) Printer control section (ECNT board)

The printer control section consists of the following components and controls the LBP printer.

a-1) Single chip microcomputer (IC 501)

The single chip microcomputer has the following main functions.

- 8-bit CPU
- 24k-byte ROM
- 512k-byte RAM
- Fixing heater control
- Thermistor detection
- Sensor detection
- Main motor control
- Toner cartridge, transfer charging roller high voltage control
- Fan control
- Paper pickup solenoid, and paper feed solenoid control
- SCNT board interface
- Scanner motor control
- Beam detection signal (nBD) detection
- Laser diode control

2.6.7 Flow of image signals

a) G3 memory transmission

- (1) The image is scanned by the contact sensor, and the analog image data is sent to the SCNT board.
- (2) The image processing IC (IC20) converts the analog image data from the contact sensor into digital data.
- (3) The digitized data is encoded by the CODEC IC in an MR with no compression function, and transferred to DRAM (IC3) by high-speed DMA transfer.
- (4) The main CPU (IC17) makes the transmission header, and encodes it with no compression.

The main CPU software CODEC decodes the encoded data held in DRAM, and converts MR -> run length -> MH/MR/MMR or MR -> raw data -> MH/MR/MMR/JBIG.

- (5) After being converted by an appropriate encoding method in the other party, a header is added, and the data is sent to the DRAM transmission buffer.
- (6) The main CPU reads the image data from the transmission buffer, and writes it to the MODEM IC (IC26), then the MODEM IC sends it to the telephone line.

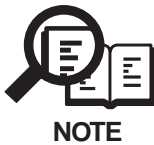

NOTE

G3 direct transmission

Direct transmission transfers image data by high-speed DMA transfer to DRAM in the same way as memory transmission. Image data up to an image memory block size of 16KB can be scanned. If the image file capacity becomes full, the scanning operation is halted. When data is transmitted and the image memory block emptied, the scanning operation begins again.

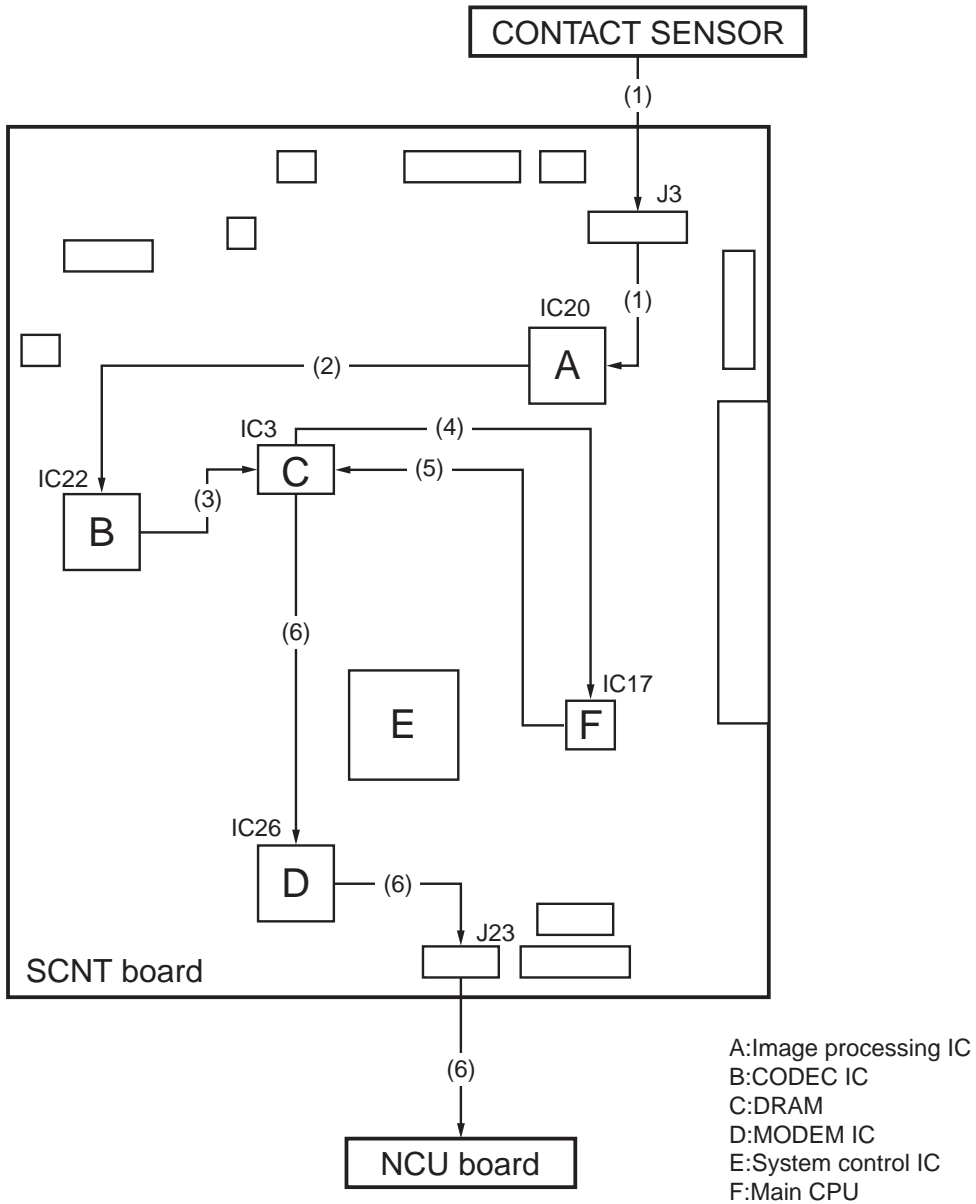

Figure 3-33 Transmission

b) G3 reception

- (1) The received image signal by L1, L2 is passed through a 2-line - 4-line conversion circuit in the NCU board, and amplified.
The encoded data received by the MODEM IC (IC26) is read out by the CPU and then it is written into the DRAM (IC3) reception buffer by the CPU.
- (2) The main CPU (IC 17) software CODEC decodes the encoded data in the reception buffer, deletes error lines, encodes to the non-compression function MR, and loads into the DRAM. The main CPU counts the number of lines and calculates the length of one page.
- (3) The main CPU determines print functions such as direct print, linear reduction, and page separation by following the length of one page, and sets a mode compatible with the system controller and the CODEC IC.
- (4) After the encoded image data recorded in the DRAM is transferred by high-speed DMA transfer to the CODEC IC, it is serially forwarded to the system control IC (IC18).
- (5) The system control IC converts the fax data resolution into a resolution suitable for print data, and sends it to the ECNT board via the TWINS board.
- (6) The ECNT board controls the main motor, laser, and high voltage for the received print data, and prints out the data.



When receiving, operations (1) and (2) above are repeated. When one page of image data is loaded into memory, the recording tasks from (3) and on are started as separate tasks.

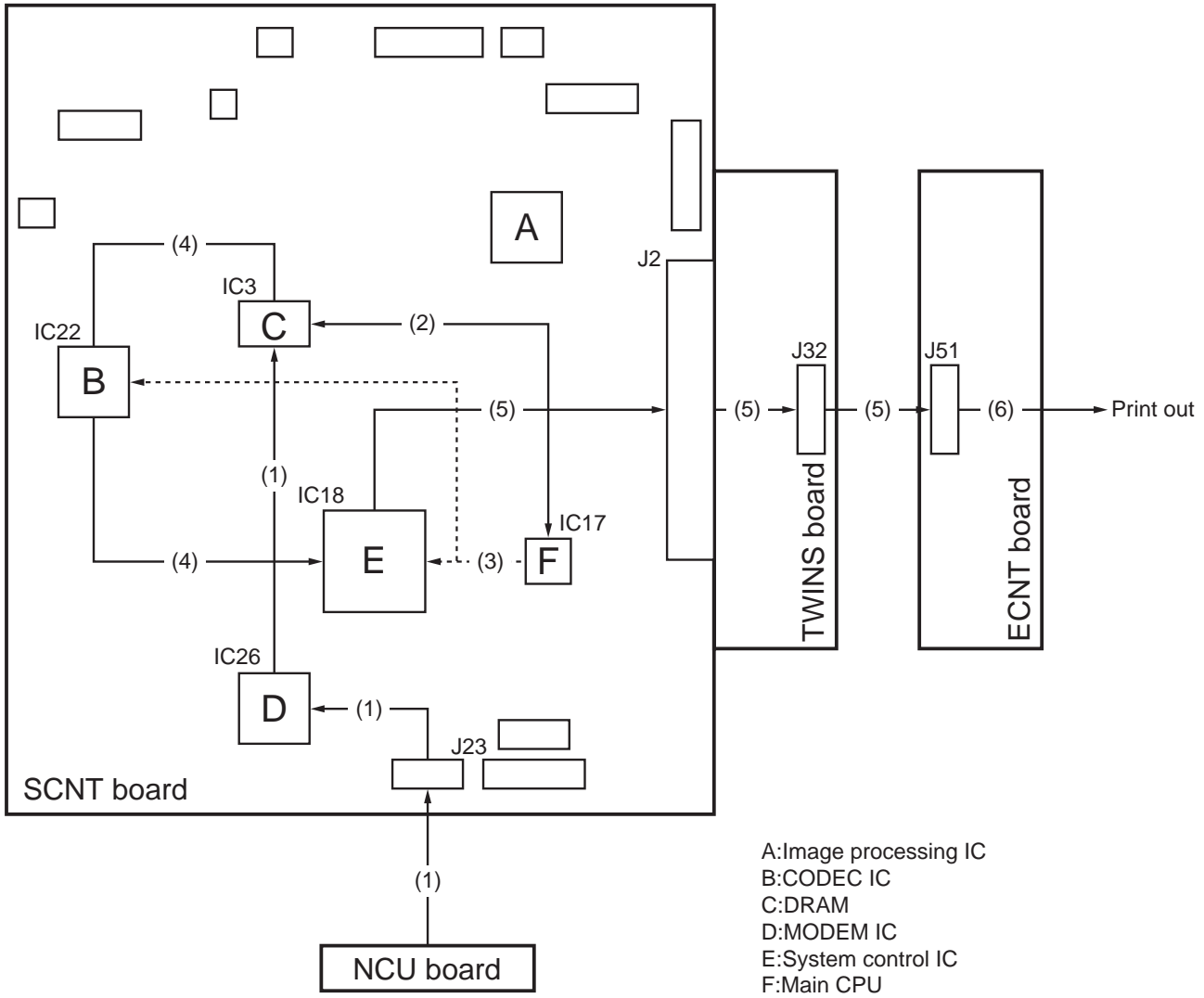

Figure 3-34 Reception

3. NEW FUNCTION

3.1 High-speed Transmission

The image transmission time is reduced drastically compared with the previous models by the V.34 modem (maximum transmission speed 33600 bps) recommended by ITU-T.

3.1.1 V.8/V.34 protocol

a) Outline

- The V.8 protocol is used as the startup protocol to move to V.34. The V.8 protocol enables connection with fax machines, data modem and equipment using existing V-series modems. The V.34 modem contains a modem circuit based on the previous recommendation to connect with the previous modems and has upper compatibility.
- The actual data transmission speed is improved entirely on average by speeding the modulation method and utilizing new techniques, such as the pre-emphasis technique^{*1} for increasing the S/N (signal-to-noise) ratio and the probing technique^{*2} for measuring line characteristics and optimizing the modem operation according to the line condition.
- The V.8 protocol, V.34 pre-protocol and post-protocol use full-duplex transmission to speed the processing.
- Fourteen image transmission speeds^{*3} are available:
33600, 31200, 28800, 26400, 24000, 21600, 19200, 16800, 14400, 12000, 9600, 7200, 4800, and 2400 bps
- The modulation speed (baud rate)^{*4} can be selected from among 2400, 3000, and 3200 symbols/sec (required) or 2743, 2800, and 3429 symbols/sec (option). The data transmission speed can be set more finely than the previous modems.



NOTE

*1 The output level of a high-frequency zone with comparatively high noise is raised, and then the transmission signal is sent.

*2 A tone signal known as a probing signal (L1 and L2) is output, and the receiving side measures the characteristics of the line.

*3 The data signaling rate is recorded in the ITU-T standards manual. Image transmission speed means the same as data signaling rate.

*4 The symbol rate is recorded in the ITU-T standards manual. Symbol rate means the same as moderation speed and baud rate.

2743 symbol/sec cannot be used with this fax.



NOTE

1. The V.34 protocol uses ECM. If the ECM SW in user data is set to OFF, the V.8 protocol is not executed. Therefore, the V.34 protocol is not used, and V.17 or a lower protocol is selected.
 2. If the transmission speed is set to 14400 bps or lower, the V.8 protocol is not executed and V.17 or a lower protocol is selected.
 3. After the V.21 protocol is selected first, it can be changed to V.8 or V.34. (See c-1))
 4. When the V.34 protocol begins, it falls back within the V.34 protocol, but it does not fall back to the V.17 mode or lower.
-

b) Typical protocol

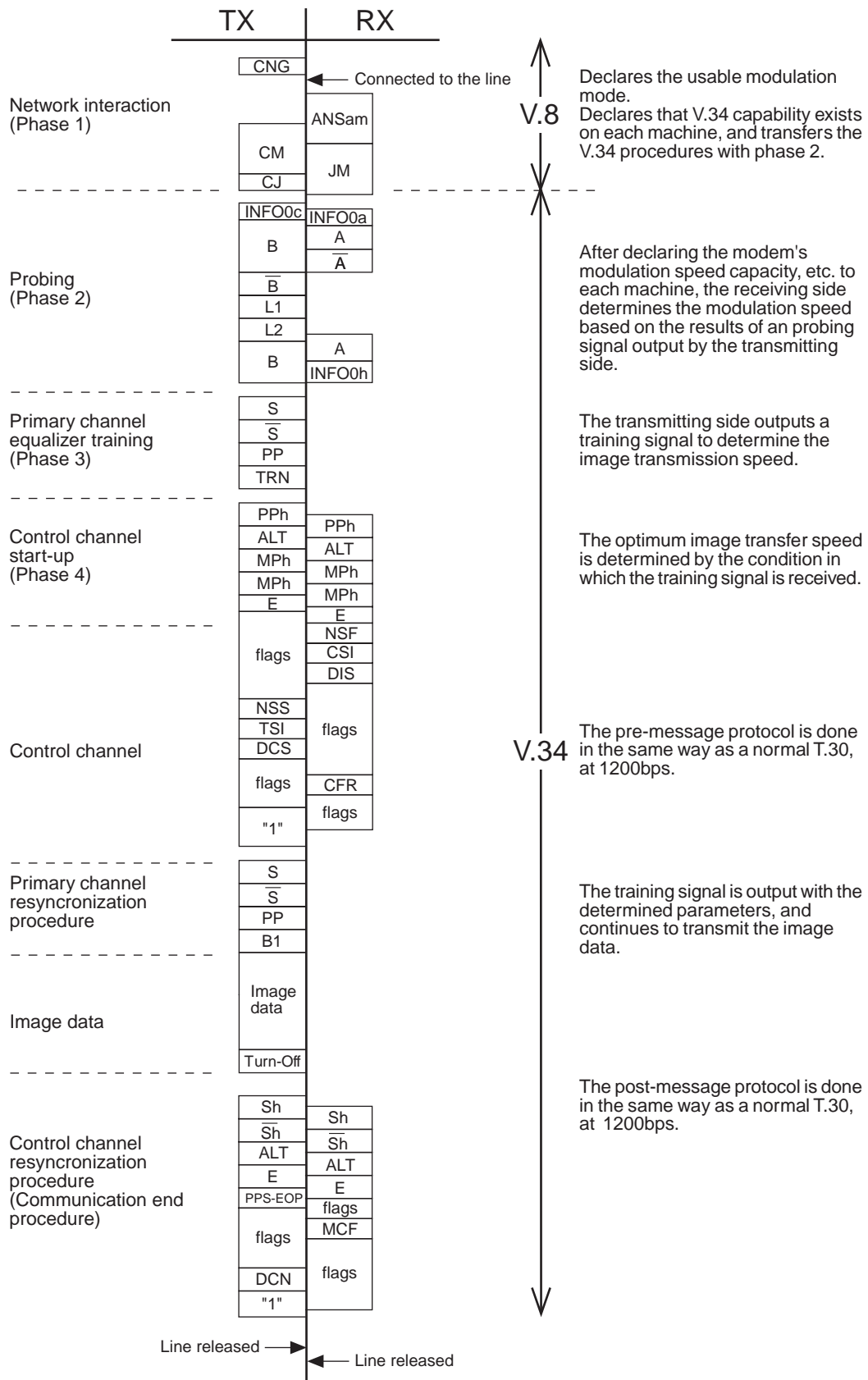

Figure 3-35 Typical Protocol

b-1) Network interaction (Phase 1)

The V.8 protocol is used as the startup protocol for high-speed modem V.34.

The V.8 protocol determines the best modulation method (V-series modem mode) that is available between the transmitter and receiver.

• Transmitter

Signal	Abbreviation	Meaning	Remarks
Calling tone	CNG	1100-Hz tone signal specified by T.30 to identify an automatic-calling fax machine.	
Dial-tone menu signal	CM	Indicate an available modulation method (V.21, V.27ter, V.29, V.17, or V.34).	Modulated by V.21(L) ^{*1} .
CM terminator	CJ	Indicate JM signal detection and CM signal termination.	Modulated by V.21(L) ^{*1} .
Dial-tone display signal	CI	Indicate the general transmission function. Sent to resume the V.8 protocol.	Late start only. (See Figure 3-36.) Modulated by V.21(L) ^{*1} .

• Receiver

Signal	Abbreviation	Meaning	Remarks
Modified response tone	ANSam	2100-Hz tone signal amplitude-modulated by 15 Hz.	Equivalent to CED for previous models.
Common menu signal	JM	Indicate the terminal type, such as a fax machine, and an available modulation method in response to the available modulation method reported by the CM from the transmitter.	Modulated by V.21(H) ^{*1} .

*1 V.21(L): Low-frequency channel defined by V.21 recommendation
1080±100 Hz (980 Hz:1, 1180 Hz:0)
Transmission speed: 300bps

V.21(H): High-frequency channel defined by V.21 recommendation
1750±100 Hz (1650 Hz:1, 1850 Hz:0)
Transmission speed: 300bps

b-2) Probing (Phase 2)

The line characteristics are measured and modulation-related parameters, such as symbol rate, are set.

• **Transmitter**

Signal	Abbreviation	Meaning	Remarks
INFO sequence	INFO0c	Indicate modem capabilities, such as baud rate and frequency transmission function (two frequency bands used to measure line characteristics), and request adjustment.	Transmission speed: 600bps
Tone B	B	Modem synchronization with a 1200-Hz tone signal.	The phase of the B-signal is inverted 180 degrees from the phase of the B signal.
Tone \overline{B}	\overline{B}		
Probing signal L1	L1	Tone signal for analyzing line characteristics by probing.	Probing: Measurement of line characteristics.
Probing signal L2	L2	Transmit the signal at a level 6 dBm higher than the transmission signal level set by the attenuator.	Tone signal in the range 150 to 3750 Hz in 150-Hz steps.

• **Receiver**

Signal	Abbreviation	Meaning	Remarks
INFO sequence	INFO0a	Report the modem capabilities, such as baud rate and frequency transmission ability.	Transmission speed: 600bps
Tone A	A	Modem synchronization with a 2400-Hz tone signal.	The phase of the A-signal is inverted 180 degrees from the phase of the A signal.
Tone \overline{A}	\overline{A}		
INFO sequence	INFO0h	Report the pre-emphasis filter and baud rate used for data transmission based on the result of analysis of the probing signal.	Transmission speed: 600bps

b-3) Primary channel equalizer training (Phase 3)

Filters, such as equalizers, are trained (adjusted) with the parameters set in phase 2.

• **Transmitter**

Signal	Abbreviation	Meaning	Remarks
S signal	S	Short training	The phase of \bar{S} is shifted from the phase of S.
\bar{S} signal	\bar{S}		
PP signal	PP	The other modem uses this signal to train the equalizer.	
TRN signal	TRN	The receiver uses this signal to determine the transmission speed.	

b-4) Control channel start-up (Phase 4)

Select the maximum data signalling rate and trellis encoder and set the data signalling rate that can be supported.

• **Transmitter/receiver**

Signal	Abbreviation	Meaning	Remarks
PPh signal	PPh	The other modem uses this signal to train the equalizer.	
ALT signal	ALT	_____	
Modulation parameter	MPh	Indicate the image transmission parameters, such as maximum data signal speed, control channel data signal speed, trellis coding type, pre-coding type, and baud rate.	
E sequence	E	_____	20-bit sequence of binary 1's.

b-5) Control channel

The conventional T.30 protocol is executed.

The transmission speed is 600bps.

• **Transmitter**

Signal	Abbreviation	Meaning	Remarks
Flag	flags	Maintain synchronization.	7E (H)
Non-standard facilities set-up	NSS	Receive NSF from the other party, select an available mode from it, and instruct reception.	
Transmitting subscriber identification	TSI	Report the transmitter telephone number.	
Digital command signal	DCS	Instruct the available mode.	
_____	1	Declare to switch to high-speed protocol.	Transmit 1's.

• **Receiver**

Signal	Abbreviation	Meaning	Remarks
Non-standard facilities	NSF	Report functions not recommended by ITU-T, user's ID, manufacturer code, etc.	
Called subscriber identification	CSI	Report the receiver telephone number.	
Digital identification signal	DIS	Report standard ITU-T-recommended functions.	
Flag	flags	Maintain synchronization.	7E (H)
Confirmation to receive	CFR	Report that modem training ends and image signal reception is ready.	



NOTE

In the control channel, signals which differ according to the frequencies of both TX and RX are output. It follows that the effects of the echo are not received because the frequencies of the signal returned by echo and the signal output by the other machine are different.

b-6) Primary channel resynchronization procedure

Training is performed with the parameters set in phase 4.
The transmission speed is 1200bps.

• **Transmitter**

Signal	Abbreviation	Meaning	Remarks
S signal	S	Short training	The phase of \overline{S} is shifted from the phase of S.
\overline{S} signal	\overline{S}		
PP signal	PP	The other modem uses this signal to train the equalizer.	
Sequence B1	B1	Scramble data frame transmitted at the end of start-up protocol.	

b-7) Image data

Transmit image data.

• **Transmitter**

Signal	Abbreviation	Meaning	Remarks
Image data	Image data	Encoded image data	
_____	Turn-off	_____	Send scrambled 1's for 35 ms.

b-8) Control channel resynchronization procedure (Communication end procedure)

Protocol for terminating transmission.

The transmission speed is 1200bps.

• **Transmitter**

Signal	Abbreviation	Meaning	Remarks
Sh signal	Sh	Short training	
$\overline{\text{Sh}}$ signal	$\overline{\text{Sh}}$		
ALT signal	ALT	_____	
E sequence	E	_____	
End of procedures	PPS-EOP	One page is transmitted.	
Flag	flags	Maintain synchronization.	7E (H)
Disconnect signal	DCN	Disconnect the line.	

• **Receiver**

Signal	Abbreviation	Meaning	Remarks
$\overline{\text{Sh}}$ signal	$\overline{\text{Sh}}$	Short training	
Sh signal	Sh		
ALT signal	ALT	_____	
E sequence	E	_____	
Flag	flags	Maintain synchronization.	7E (H)
Message confirmation	MCF	Indicate that the receiver has received the image signal correctly and can receive the next document immediately.	

c) Examples of sequences

The signals in the shaded areas are important in the protocol.

c-1) Late start

Since the receiver cannot detect the CM signal while sending the ANSam signal, it sends the DIS signal containing the "V.8 protocol" declaration. The transmitter sends the CI signal to request the receiver to send the ANSam signal again to move to V.8 protocol.

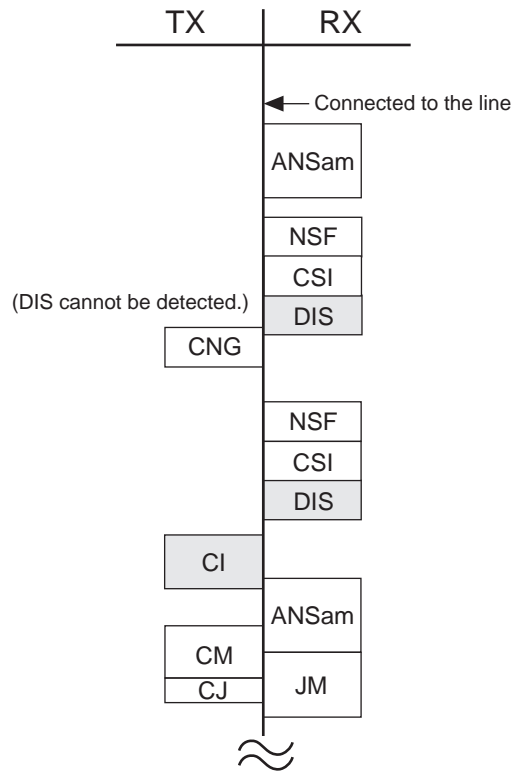

Figure 3-36 Late Start

c-2) Between-page sequence

The transmitter sends image data, then the PPS-MPS signal in the same as for the T.30 protocol. The receiver sends the MCF signal to receive the next page.

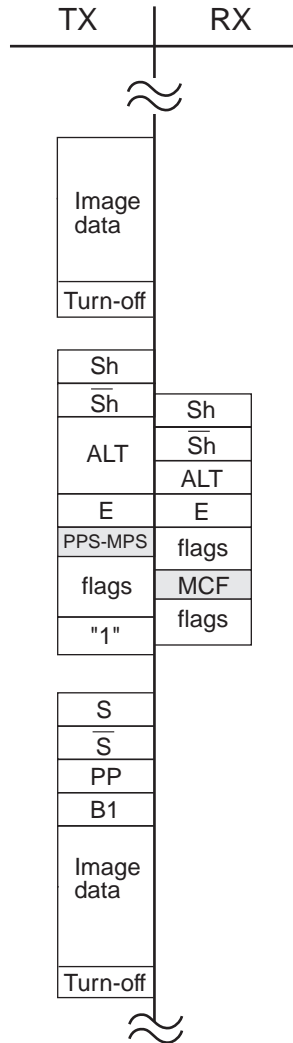

Figure 3-37 Between-page Sequence

c-3) Mode change

The transmitter sends PPS-EOM and the receiver sends the MCF signal. Then the receiver sends the DIS signal and the transmitter sends the DCS signal to change the mode.

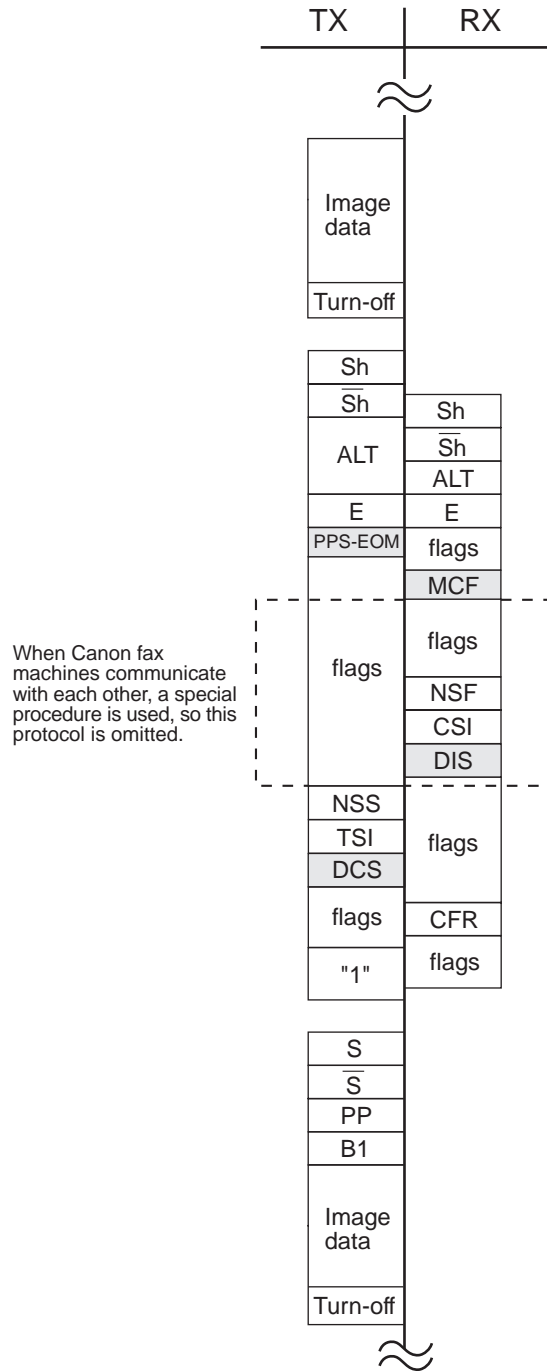

Figure 3-38 Mode Change

c-4) Image transmission speed change from the receiver

The receiver returns to the PPh signal in response to the Sh signal from the transmitter. The image transmission speed is then determined by the MPh sequence sent from both modems.

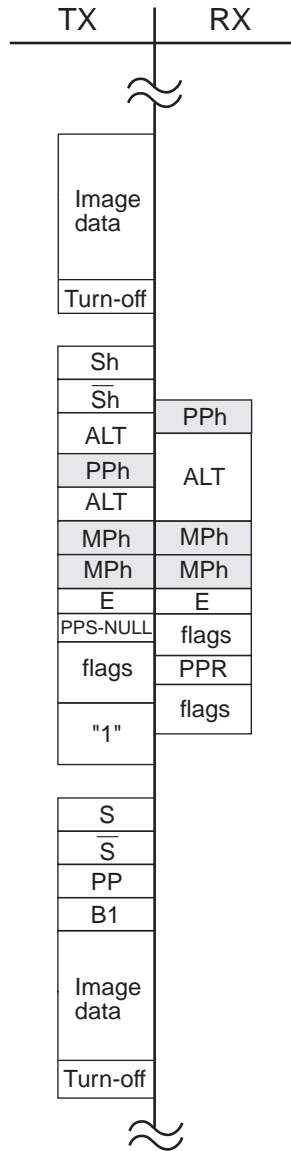

Figure 3-39 Image Transmission Speed Change from the Receiver

c-5) Image transmission speed change from the transmitter

The transmitter sends image data, and then the PPh signal, and the receiver returns the PPh signal to the transmitter. The image transmission speed is then determined by the MPh sequence sent from both modems.

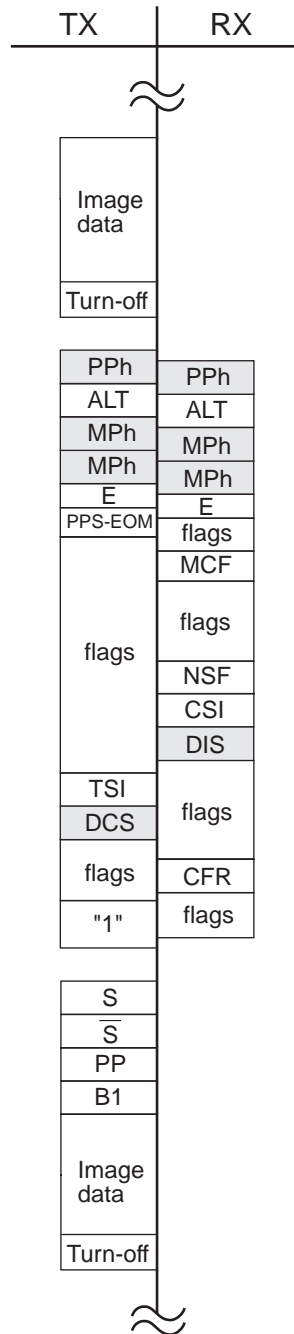

Figure 3-40 Image Transmission Speed Change from the Transmitter

3.2 JBIG Image Compression Encoding Method

3.2.1 Outline of the JBIG Image Compression Encoding Method

The JBIG Image Compression Encoding Method is recommended in ITU-T T.82/T.85 as a new bi-level (bi-level: White and Black) image compression encoding method developed by JBIG (Joint Bi-level Image experts Group).

The JBIG Image Compression Encoding Method has the following characteristics with regards to text documents, quasi-gray scale images with little continuous black and white, and gray scale images which use a dithering method: a higher compression rate (1.1~30 times higher) than the conventional MMR compression method, the encoded volume will not exceed the volume of original image information after compression, and when decoding, the image can be completely re-assembled to its original condition in the same way as with conventional MR/MMR.

The JBIG Image Compression Encoding Method contains Progressive Bi-level Image Compression for searching image databases, recommended in ITU-T T.82, and Single Progression Sequential Bi-level Image Compression for facsimile, recommended in ITU-T T.82 and T.85.

Images will take on the form shown below.

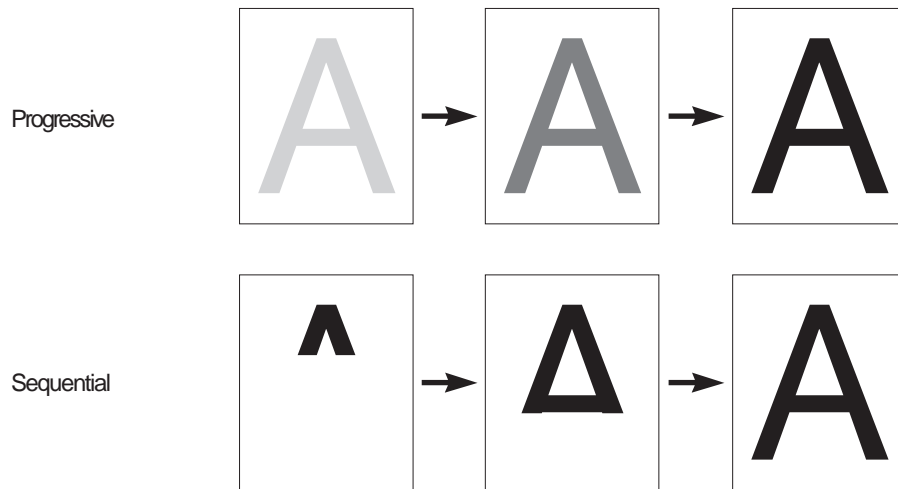
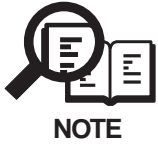

Figure 3-41 Images



The characteristics of Progressive Bi-level Image Compression are explained below as a reference. First of all, after the original image has been read in at high resolution, it is converted to low resolution, and this low resolution image data proceeds to be encoded (compressed). On the receiving end, the overall original image can be quickly recognized by the steps in which this low resolution image compression data is received.

Next, to improve the quality of the low resolution image already sent, only information needed to improve the resolution is forwarded. The previous low resolution image is decoded on the receiving side with this information, and following this, the high resolution image is displayed on top of the previous low resolution image.

It is easy to quickly recognize the original image in the process of displaying the image from low resolution to high resolution in order by using this method, with a CRT display for example. Also, according to the situation, it is possible to interrupt the image transfer at the point where the original image is recognized to some degree by the receiving side.

This method requires a page buffer memory for the low resolution image because the low resolution images are used for the purpose of high resolution image encoding.

3.2.2 Single Progression Sequential Bi-level Image Compression Method

The Single Progression Sequential Bi-level Image Compression Method used in this fax is explained below.

The Progressive Bi-level Image Compression Method uses multiple resolution layers on a single page (multi-level layers, low resolution layers~high resolution layers) to perform encoding/decoding. In the Single Progression Sequential Bi-level Image Compression Method, encoding is done in units of horizontal bands (a number of lines) called stripes, and is performed from left to right, top to bottom (this condition is called sequential), and in one resolution layer (single layer).

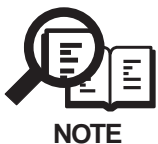

In this method, the encoding is done in stripe units, so it is completed with a buffer memory much smaller than a page buffer memory.

The methods by which encoding takes place and by which image data is constructed after encoding are explained below.

3.2.3 Encoding Method

In the JBIG encoding used in the Single Progression Sequential Bi-level Image Compression Method, uses in the encoder shown below to encode to the original the results of comparison of the line currently being processed and the previous line, as well as the predicted value of an image pixel (white or black) used in a model template.

The study table used in the prediction makes the next prediction more accurate by learning and correcting the study table every time the model template moves to the adjoining pixel. It is characteristic of this method that if the prediction is accurate the amount of encoding will not increase, and if the prediction is off the amount of encoding increases, so the increase in prediction accuracy of this study table is very important.

An outline of the encoding procedure is shown below.

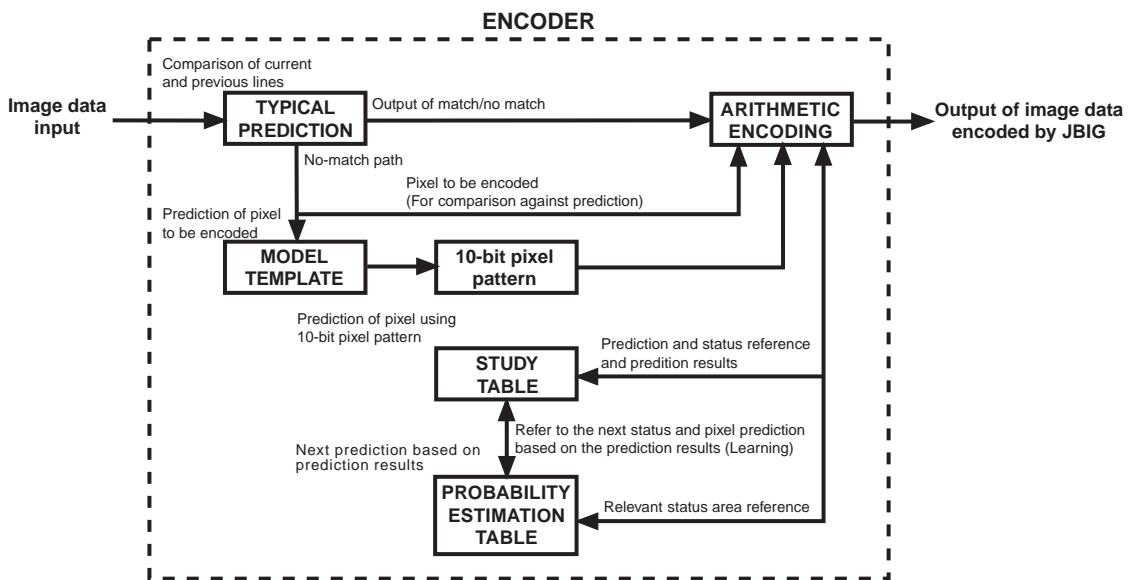
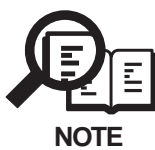

Figure 3-42 Encoder and Flow of JBIG Encoding

- a) In the pattern prediction section, the line currently being processed and the current line are compared, and judged to match or not match. A flag showing whether or not the lines match (1 bit, 0: match, 1: don't match) is attached to the head of each line according to this judgment. When the lines match, only this flag is encoded in the arithmetic encoding section as a suspected pixel, the pixel of the line being currently processed is not encoded. When the lines do not match, the pixel of the line currently being processed is encoded in the arithmetic encoding section based on the results of a comparison of the value of the actual pixel and the pixel (white or black) which is predicted using the model template and the study table.



When the lines are judged to match, the line currently being processed is said to be “typical”. When the lines are judged to not match, the line is said to be “not typical”. When the very first line of an image is predicted, the background color is used as the previous line.

- b) In the model template, the combination (10-bit pixel pattern) of 10 pixels is output to the arithmetic encoding section using the template shown below (inside the bold outline). All of the 10-bit pixel patterns inside this template exist in the study table. This 10-bit pixel pattern is used by the arithmetic encoding section to refer to the predicted value of the pixel and the status number in the study table which correspond to the 10-bit pixel pattern.

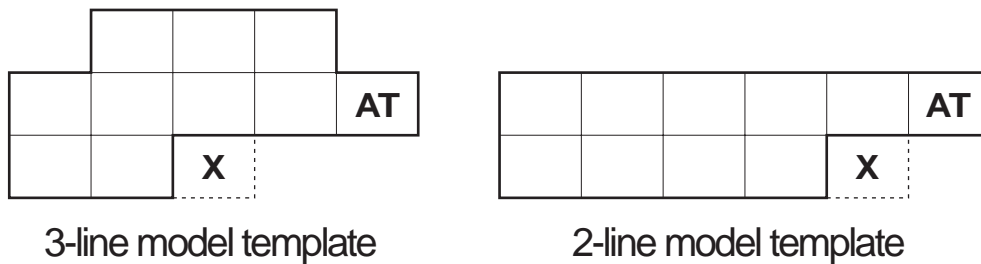
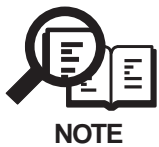

Figure 3-43 Model Templates



There are two types of model templates 3-line and 2-line, and the one selected is designated by the LRLTWO inside the Bi-level Image Header section (BIH). The pixel shown by “X” is an encoded pixel and is outside of the template.

The pixel shown by “AT” is a special pixel known as an AT pixel. The AT pixel becomes a Adaptive Template by having its position moved, and is very effective when encoding a periodic pixel, similar to a dither pattern image.

The position of AT in the figure is the beginning position of the AT pixel.

In this fax, it remains fixed in this initial position, so Adaptive Template is not used.

- c) The study table, as shown below, is constructed by all of the 10-bit pixel patterns output by the model template, and their corresponding status numbers and predicted values of the pixel to be encoded.

The predicted value of the pixel to be encoded and the status number is compared to the actual pixel in the arithmetic encoding section every time the model template is moved to the adjoining pixel.

The result of this comparison (matches / does not match predicted value) and the status number are then checked by comparison to the probability estimation table, and the study table is corrected (learned) to a new prediction value and status number which will be used when the same pixel pattern is found again.

By learning in this way, the probability of the study table matching the next time is increased, and the need for encoding decreased.

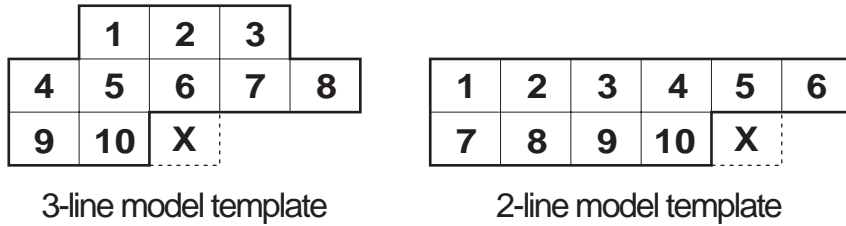

Figure 3-44 Positions of Pixels in Model Template

Table 3-1 Study Table (Initial values)

		Pixel pattern in the model template										Predicted value of pixel	Status No. (ST)
Hex	Dec	1	2	3	4	5	6	7	8	9	10		
000h	0	0	0	0	0	0	0	0	0	0	0	0 (white)	0
001h	1	0	0	0	0	0	0	0	0	0	1	0 (white)	0
002h	2	0	0	0	0	0	0	0	0	1	0	0 (white)	0
003h	3	0	0	0	0	0	0	0	0	1	1	0 (white)	0
004h	4	0	0	0	0	0	0	0	1	0	0	0 (white)	0
005h	5	0	0	0	0	0	0	0	1	0	1	0 (white)	0
~													
3FBh	1019	1	1	1	1	1	1	1	0	1	1	0 (white)	0
3FCh	1020	1	1	1	1	1	1	1	1	0	0	0 (white)	0
3FDh	1021	1	1	1	1	1	1	1	1	0	1	0 (white)	0
3FEh	1022	1	1	1	1	1	1	1	1	1	0	0 (white)	0
3FFh	1023	1	1	1	1	1	1	1	1	1	1	0 (white)	0

Table 3-2 Probability Estimation Table

ST	LSZ	NLPS	NMPS	SWITCH	ST	LSZ	NLPS	NMPS	SWITCH
0	5A1Dh	1	1	1	57	01A4h	55	58	0
1	2586h	14	2	0	58	0160h	56	59	0
2	1114h	16	3	0	59	0125h	57	60	0
3	080Bh	18	4	0	60	00F6h	58	61	0
4	03D8h	20	5	0	61	00CBh	59	62	0
5	01DAh	23	6	0	62	00ABh	61	63	0
6	00E5h	25	7	0	63	008Fh	61	32	0
7	006Fh	28	8	0	64	5B12h	65	65	1
8	0036h	30	9	0	65	4D04h	80	66	0
~									
49	0706h	79	50	0	106	50E7h	108	107	0
50	05CDh	48	51	0	107	4B85h	109	103	0
51	04DEh	50	52	0	108	5597h	110	109	0
52	040Fh	50	53	0	109	504Fh	111	107	0
53	0363h	51	54	0	110	5A10h	110	111	1
54	02D4h	52	55	0	111	5522h	112	109	0
55	025Ch	53	56	0	112	59EBh	112	111	1
56	01F8h	54	57	0					

- ST: Status number in the study table
- LSZ: Probability estimation value (range) for inaccurate prediction
- NLPS: Next status destination when a prediction is inaccurate
- NMPS: Next status destination when a prediction is accurate
- SWITCH: Next prediction value reversed if SWITCH=1 when prediction is inaccurate

Example:

A brief explanation of how the study table works is given below.

It is assumed that each of the model template pixels 1~10 in the image below are white.

1. In this case, the model template pixel pattern is 000h.
2. The predicted value of pixel pattern 000h for pixel “X” is “white”, but it is actually black. Thus the prediction is “inaccurate”.
3. The status ST is “0”, so the probability estimation table is consulted, and the next status is moved to “1”. At the same time, by the reversal of the predicted value, the next prediction is for “black”.

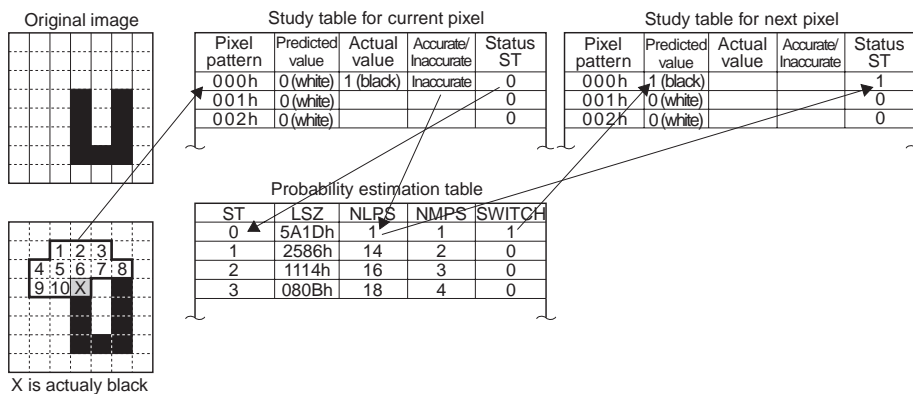

Figure 3-45 Study Table Study Example 1

4. Next, the model template is moved to the adjoining pixel in order to perform the next prediction. At this time, pixels 1~9 of the model template are white, and pixel 10 is black.
5. In this case, the model template pixel pattern is 001h.
6. The predicted value of pixel pattern 001h for pixel “X” is “white”, and it is actually white. Thus the prediction is “accurate”.
7. The status ST is “0”, so the probability estimation table is consulted, and the next status is moved to “1”. The prediction for the next pixel remains “white”.

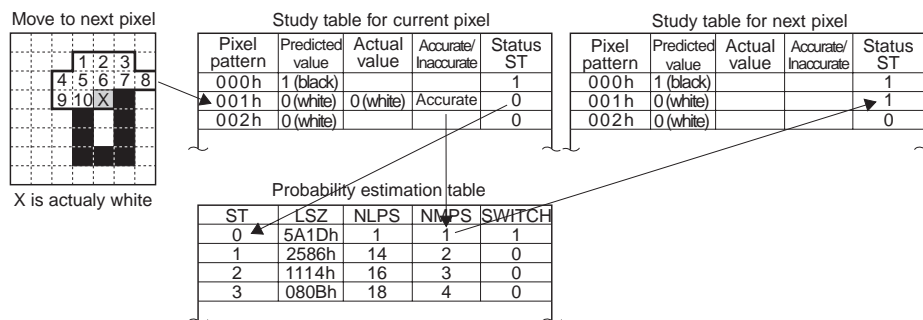
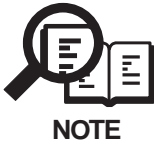

Figure 3-46 Study Table Study Example 2

The study table is constantly updated in this way, increasing the probability of accurate predictions.

- d) The probability estimation table, published in the ITU-T T.82. Its contents are fixed, differing from those of the study table.



NOTE

This table shows probability of accuracy/inaccuracy in the form of a range, according to the accurate/inaccurate results of a given status prediction value. The plan of the probability estimation table is such that if the prediction is accurate, the range of the next status number will be smaller than would be the case in an inaccurate prediction. The status number with this smaller range will be selected to be the next status number.

- e) After the predicted value is found to be accurate/inaccurate by the actual pixel, the model template, and the study table, that accuracy/inaccuracy is encoded in the arithmetic encoding section, and the encoded image data is output.
- f) In the encoding (mathematical encoding) done in the arithmetic encoding section, there is no conversion table for encoding as is the case in encoding with conventional MH and MR. Using the LSZ (probability estimation value of an inaccurate prediction: the form of a range) of the probability estimation table and the accuracy/inaccuracy of the predicted value as a base, encoding is done by showing the position of the progress of the prediction on an integer line (between 0~1.0). Encoding shown as a position on this integer line, take a position under MPS in the case of accurate predictions, and under LPS in the case of inaccurate predictions, as shown in the figure below.

Furthermore, there is a concept of range (A) in this arithmetic encoding. This range (A) ^{*2} is shown as an MPS range in the case of accurate predictions and as an LPS range in the case of inaccurate predictions for each pixel. When these ranges (A) are below a certain range ^{*3}, the leading edge bit (which excludes the encoding “0.” shown by the position on the integer line) shifts one position to the left as encoded image data, and is output. At this time, the limit of this range (A) which was below the certain range is narrow and it is difficult to show a position more detailed than this, so the range (A) is magnified ^{*4} to show it in more detail. This operation is called “Renormalization”, and this range (A) is reset to a value above a certain range ^{*3}.

The concept of arithmetic encoding is simply explained below.

The following assumptions are made in order to make the explanation easy to understand.

The probability of accuracy will be 50%, and the probability of inaccuracy will be 50%.^{*1}

The area of accuracy will be MPS, and the area of inaccuracy will be LPS.

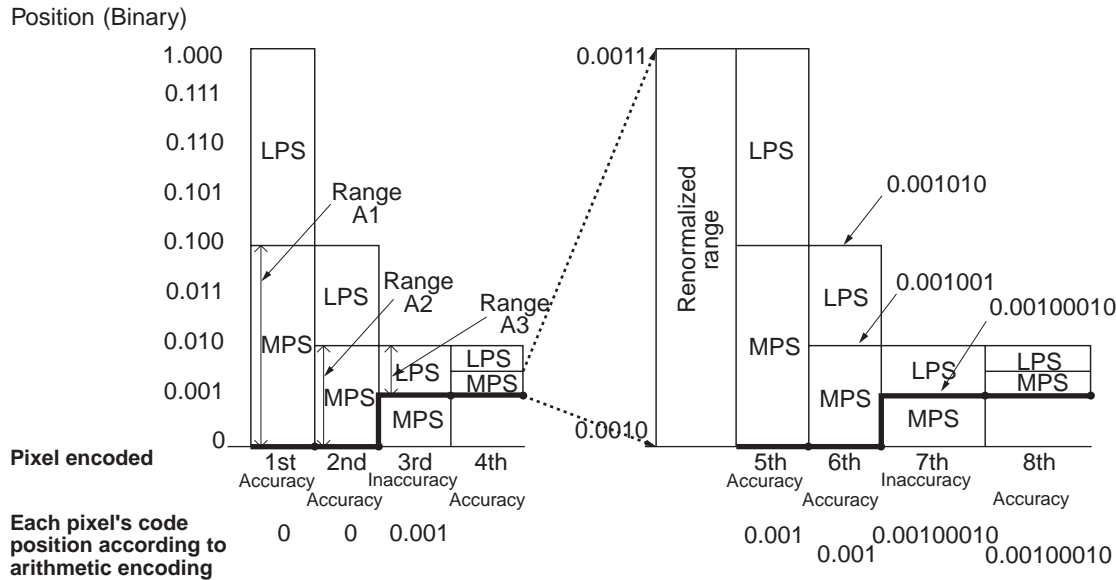
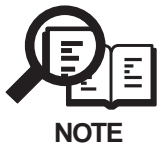

Figure 3-47 Arithmetic Encoding Conceptual Diagram

The special characteristic of this arithmetic encoding is that an additional encoding bit is not needed because the integer line position is the same as the integer line position of the previous encoding data in the case of an accurate prediction. It follows that the amount of encoding will not increase if accurate predictions continue, and the rate of compression will increase. Conversely, with inaccurate predictions, an additional encoding bit will be necessary to show the position of the inaccuracy in detail, and thus the amount of encoding will increase and the rate of compression decrease. In this way, the study table learns in order to increase the rate of accurate predictions and to reduce the amount of encoding and raise the compression rate during the encoding process, and then corrects the table parameters.



- *1 The actual probability varies with the status because of the extent to which LSZ occupies in the range (A).
- *2 The actual range is hexadecimal 8000~10000.
In the case of an accurate prediction, range A1= hexadecimal 10000-LSZ, A2=A1-LSZ, and A3=A2-LSZ.
In the case of an inaccurate prediction, range A=LSZ.
- *3 Actually, hexadecimal 8000.
- *4 Actually, the hexadecimal value will be shifted to the left two times, and the hexadecimal will be over 8000.

Next, the encoding for continuous accurate predictions will be simply explained. The assumptions below will be made for easy understanding.

The value of an accurate LSZ will be decimal 100^{*1} in all statuses.

Range A will have limits of decimal $8000 \sim 10000^{**2}$, and when range A is below decimal 8000^{*3} , the lead encoding bit will be pushed out, and the encoded image data will be output.

At this time, Range A will be adjusted so that it is over decimal 8000^{*3} (decimal 1000^{*4} added).

An accurate range will be MPS, and an inaccurate range will be LPS.

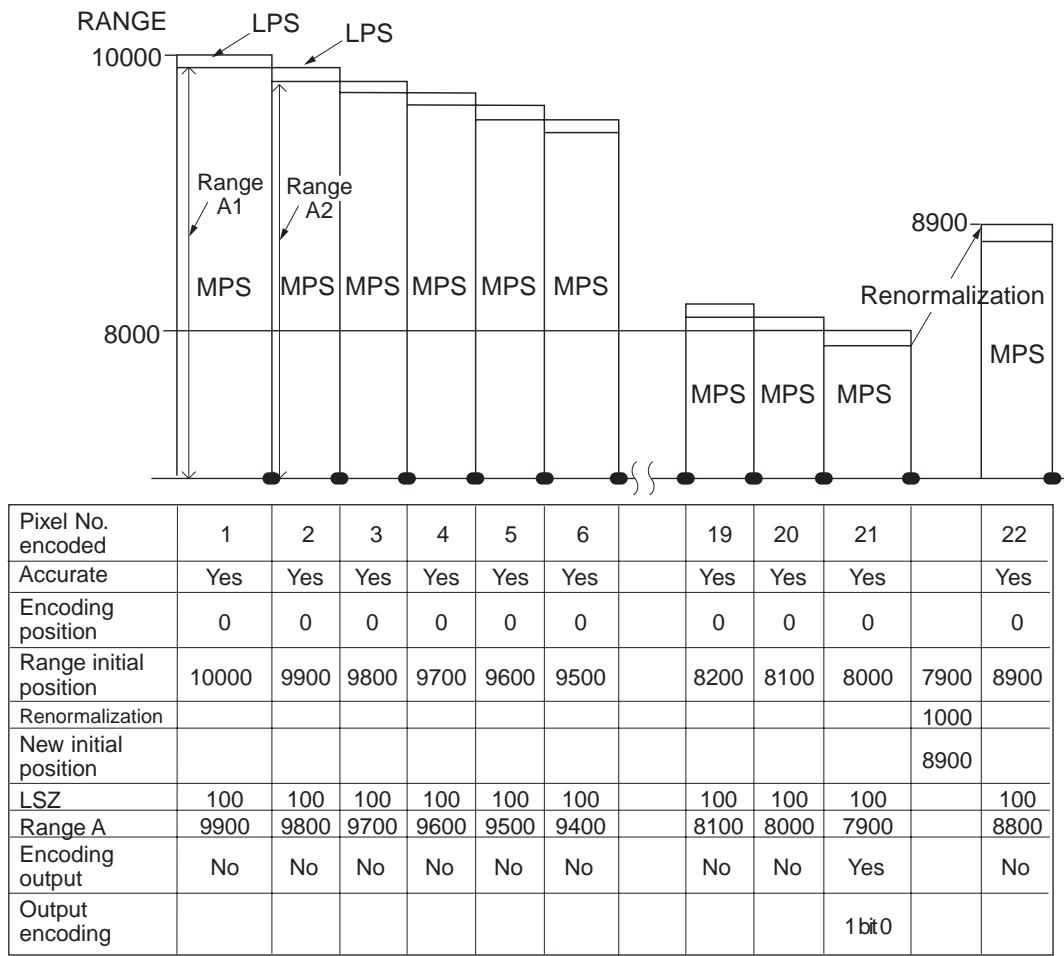

Figure 3-48 When Predictions are Continually Accurate

In this case, the encoding 1 bit is output for the first time when Range A falls becomes less than 8000 in the 21st pixel.

The following output encoding is shortened and its compression increased.

3.2.4 Construction of image data with JBIG Image Compression Encoding

Images are encoded in block units called stripes, as shown in the figure below.

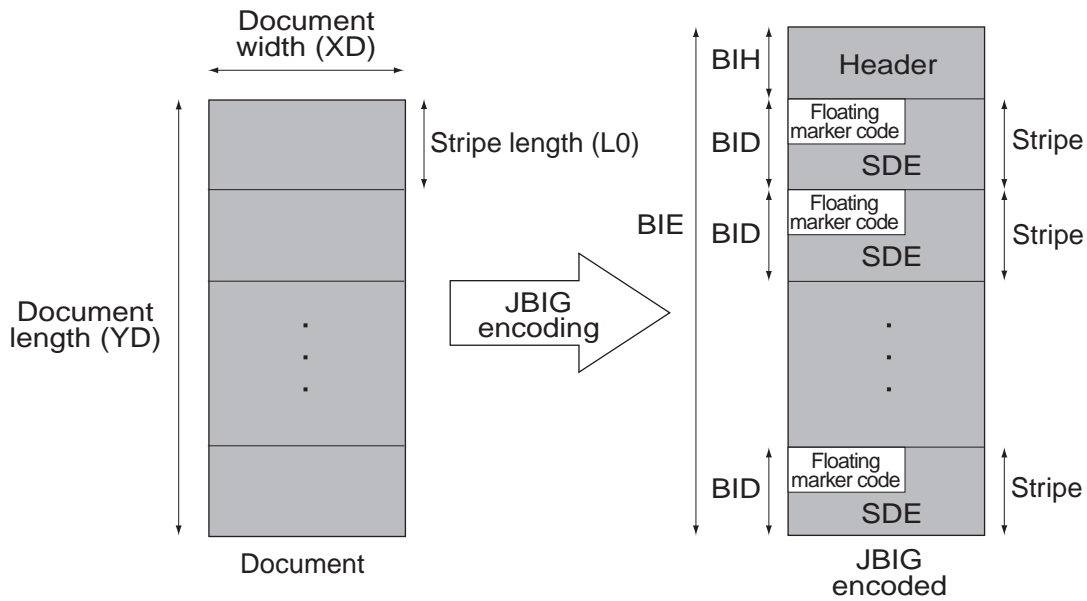

Figure 3-49 Construction of JBIG Image Data

After being encoded, the image data is referred to as BIE (Bi-level Image Entity), and is constructed from the Bi-level Image Header (BIH) section and the Bi-level Image Data (BID) section shown in the figure below.

BIE (Bi-level Image Entity)			
BIH (Bi-level Image Header)	BID (Bi-level Image Data)	BID (Bi-level Image Data)

Figure 3-50 BIE Construction Diagram

3.2.5 Explanation of Bi-level Image Header section (BIH)

The BIH is shown in the construction figure below. It designates the image size, number of lines per stripe, model template, etc.

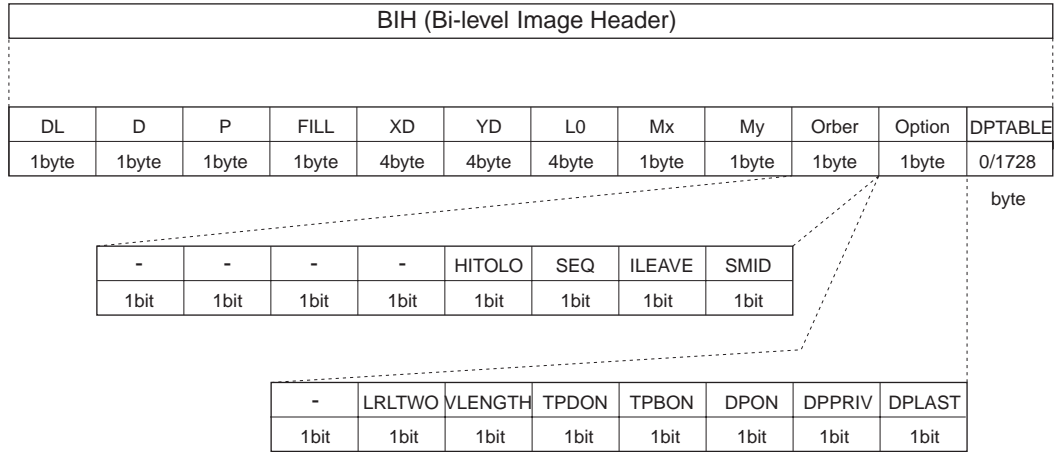

Figure 3-51 BIH Construction Diagram

3.2.6 Explanation and parameters for each symbol used in BIH

The 0x of each parameter shows that the following integers are hexadecimal.

Symbol	Meaning	Parameter	Reference
DL	Initial layer to be transmitted	0x00 fixed	
D	Number of differential layers	0x00 fixed	
P	Number of bit planes	0x00 fixed	
FILL	Fill	0x00 fixed	
XD	Horizontal image size at layer D	0XXXXXXXXXX	Document width (No. of bits)
YD	Vertical image size at layer D	0XXXXXXXXXX	Document length (No. of bits)
L0	Lines per stripe at the lowest resolution	0XXXXXXXXXX	Basically, 1 stripe is 128 lines (0x00000080). Stripes with other numbers of lines are possible when the other machine can receive in option mode.
Mx	Maximum horizontal offset allowed for AT pixel	0xXX	0-127 pixels
My	Maximum vertical offset allowed for AT pixel	0x00 fixed	
Order	The order in which stripe data is attached	Upper 4 bits 0 fixed	
Option	Option	Upper 1 bit 0 fixed	
DPTABLE	Private DP table	0 or 1728 bytes	
HITOLO	Transmission order of differential layers	1 bit 0 fixed	
SEQ	Indication of progressive-compatible sequential coding	1 bit 0 fixed	
ILEAVE	Interleaved transmission order of multiple bit plane	1 bit 0 fixed	
SMID	Transmission order of stripes	1 bit 0 fixed	
LRLTWO	Number of reference lines	1 bit 0/1	0: 3 lines 0: 2 lines
VLENGTH	Indication of possible use of NEWLEN marker segment	1 bit 0/1	Use of 0: NEWLEN not allowed Use of 1: NEWLEN allowed
TPDON	Use of TP for Typical Prediction for differential layers	1 bit 0 fixed	
TPBON	Use of TP for base layer	1 bit 0/1	0: OFF 1: ON
DPON	Use of Deterministic Prediction	1 bit 0 fixed	
DPPRIV	Use of private DP table	1 bit 0 fixed	Has meaning when DPON is 1.
DPLAST	Use of last DP table	1 bit 0 fixed	Has meaning when DPON is 1.

3.2.7 Explanation of Bi-level Image Data (BID) section

BID is as shown in the construction figure below, and consists only of the number of stripes. BID is constructed by the connection of the floating marker code and the section which includes the actual image data encoded with JBIG image compression encoding, called SDE (Stripe Data Entity).

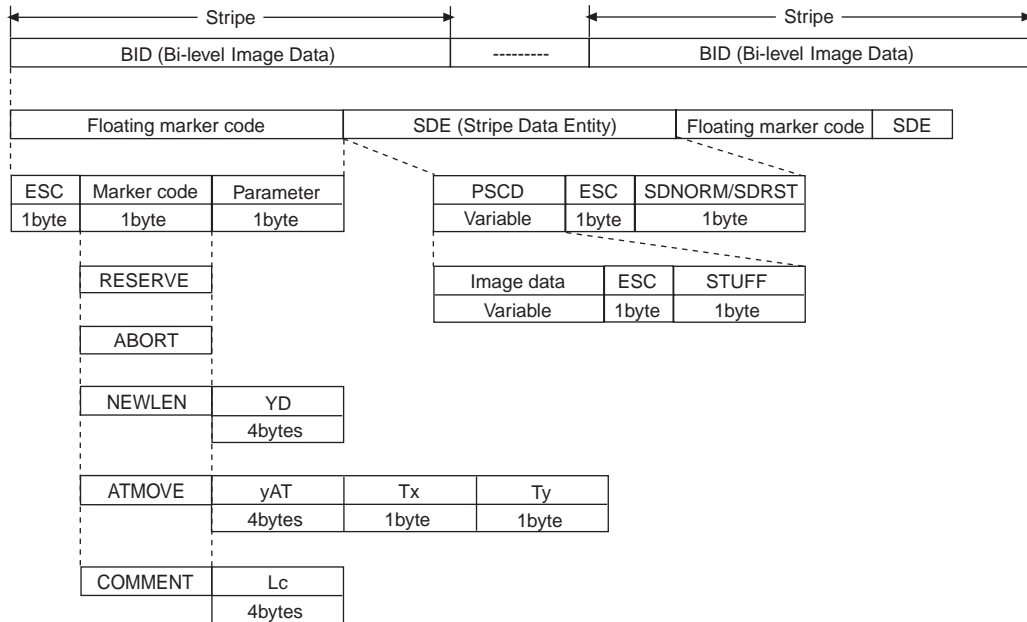

Figure 3-52 BID Construction Diagram

3.2.8 Explanation and parameters for each symbol used in BID

a) Floating marker code section

The floating marker code is set at the head of the stripe data entity (SDE).

In order to distinguish the encoding and the floating marker code, it is imperative that ESC (escape code: 0xFF) be set at the head.

The following marker code and parameters are in the floating marker code.

The 0x of each marker code shows that the following integers are hexadecimal.

ABORT (Abort: 0x05)

Encoding interruption. Only the abort code can be made to appear anywhere.

ESC	0x05
-----	------

ATMOVE (AT move: 0x06)

Designates from which line the movement of the AT pixel starts, and where it will move to.

ESC	0x06	yAT:Movement-starting line	Tx:Movement Position(X)	Ty:Movement Position (Y)
-----	------	----------------------------	-------------------------	--------------------------

COMMENT (Private comment: 0x07)

An optional comment may be added.

ESC	0x07	Lc:Comment length
-----	------	-------------------

NEWLEN (New length: 0x04)

Redefine the document length. Only usable when VLENGTH=ON.

ESC	0x04	YD:Document length
-----	------	--------------------

RESERVE (Reserve: 0x01)

Only usable for characteristic use.

ESC	0x01
-----	------

b) Stripe data section

PSCD (Protected stripe encoding data)

The actual image data encoded with JBIG image compression is included in PSCD by the section remaining after the last 2 bytes from SDE, ESC and SDNORM or SDRST are omitted.

Image Data

The actual image data encoded with JBIG image compression.

STUFF

Image data is a variable, so STUFF:0 (zero) is adjusted by continuous sending so that the image data can be arranged into byte units or word (2 byte) units.

SDNORM (Stripe data completion: 0x02)

Shows the completion of stripe data

ESC	0x02
-----	------

SDRST (The reset at completion of stripe data: 0x03)

Shows the completion of stripe data. Everything including the study table and the ATMOVE are reset.

ESC	0x03
-----	------



NOTE

When the image data encoding is 0xFF, it is imperative to attach 0x00 after the image data encoding 0xFF in order to distinguish ESC(0xFF).

3.3 Energy Save Standby (ESS)

a) Function

ESS is an energy save function for minimizing power loss during standby.

During ESS, the ESS control section of the system control IC inside the SCNT board halts all oscillators other than the real time clock (RTC) IC in order to reduce power loss. Because of this, the operation of ICs etc. receiving clock supply from the oscillators is halted. Also, the functions of parts of the system control IC itself which receive clock supply from the oscillators are halted as well. Only those parts which receive clock supply from the real time clock IC continue to operate, and in this manner an idle condition (sleep mode) is created. Additionally, the main CPU and modem are also put into sleep mode by a sleep mode signal from the system control IC.

Also, the supply of power other than the 5V from the PSU will be interrupted, and the operation of ECNT board and other boards will be halted.

Power standby is performed in this way, through the halting of the operations of some of electrical parts on the ECNT and SCNT boards.

The main functions of the ESS control section in ESS mode are as follows:

- Display management Control LCD display on the OPCNT board.
- Startup factor detection Monitor startup factors all the time.
- Main unit start management Enable the main unit when a startup factor is detected.

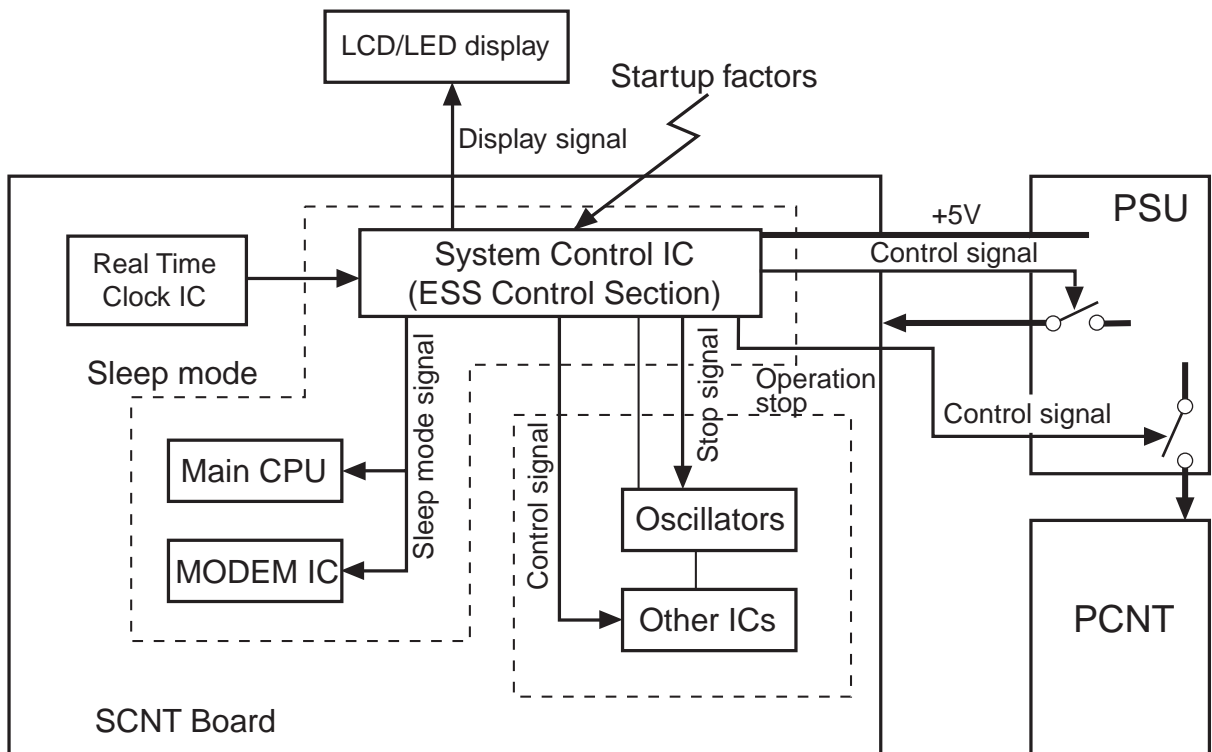

Figure 3-53 System Block Diagram



NOTE

The power consumption at standby is 22 W in non-ESS mode and 2 W in ESS mode.

The ESS function does not operate when the FAX-L1000 ISDN Kit or FAX-L1000 Printer Kit are installed.

b) Operation

The ESS function sets the main unit to the ESS mode if the next operation is not carried out within about three minutes after the main unit ends transmission, reception, or copying.

When the main unit enters the ESS mode, the ESS control section monitors one of the following start factors for the main unit. If it detects it, it cancels ESS.

1. CI termination
2. Off-hook
3. ESS button pressing
4. Report output time
5. Timer calling time
6. Document sensor “ON”



NOTE

• All LEDs, except ESS-LED are off and “ENERGY SAVER” is displayed on the LCD in ESS mode.

• The main unit does not enter ESS mode if any of the following conditions is met:

1. The ESS mode is not enabled by user data settings.
 2. The error lamp is on due to no recording paper, jam, no toner, or a service error.
 3. Data is stored in the image memory.
 4. There is one or more documents in the ADF.
-

c) Setting

The ESS is enabled by setting 10. ENERGY SAVER, 7. System setting, in user data settings to ON. (Default: OFF)

The time after the main unit ends operation until it enters the ESS mode can be set (3 to 30 min.).

Chapter 4

Maintenance and Service

1. MAINTENANCE

1.1 Maintenance Items

1.1.1 Consumables

Level	Consumable	When
User	Canon FX 6 Cartridge	When “INSTALL CARTRIDGE” is displayed or when toner has run out.
	Stamp ink* ¹	When the stamp becomes thin.
	Recording paper* ²	When paper runs out.
Service technician	Separation roller (upper)* ³	Expected life: 75,000 sheets
	Separation roller (lower)* ³	Expected life: 75,000 sheets
	Multi-purpose tray pick-up roller* ³	Expected life: 100,000 sheets
	Separation pad* ³	Expected life: 200,000 sheets
	Cassette feed roller* ^{3*4}	Expected life: 200,000 sheets
	Cassette separation roller* ^{3*4}	Expected life: 200,000 sheets
	Torque limiter (for cassette separation roller)* ^{3*4}	Expected life: 200,000 sheets
	Multi-purpose pick-up clutch* ³	Expected life: 200,000 sheets
	Fixing unit* ³	Expected life: 200,000 pages
	Transfer charging roller* ³	Expected life: 200,000 pages
	Cooling fan* ³	Expected life: 25,000 hours (or When the fan is not stopped during the standby condition.)



NOTE

*¹ Please use “Shachihata X Stamper Inks CS-20 Yellow (H12-3372)” for the stamp.

*² Recommended recording paper is shown below.

Canon Copier LTR/LGL Premium Paper	
Weight	75 g/m ²
Paper size	Letter, Legal
Manufactured by	BOISE CASCADE

KANGAS

Weight	80 g/m ²
Paper size	A4
Manufactured by	KANGAS

NEUSIEDLER Canon Paper

Weight	80 g/m ²
Paper size	A4
Manufactured by	NEUSIEDLER



NOTE

^{*3} Consumable parts are expected to require replacement at least once during the warranty period of this fax, due to deterioration or damage. The life span of consumable parts is expressed in terms of hours or number of scans or prints processed. Replace them when the parts are proven faulty. The expected life of consumable parts is the data as of February, 1999.

^{*4} Replace the cassette feed roller, the cassette separation roller, and the torque limiter together.

1.1.2 Cleaning

Level	Location	When
User	Main unit outer cover	When dirty.
	Document pick-up roller	When document pick-up performance fails.
	Document separation roller (upper)	When document separation or feed performance fails.
	Document separation roller (lower)	When document separation or feed performance fails.
	Document feed roller	When document feed performance fails.
	Document eject roller	When document feed performance fails.
	Scanning glass	When black vertical stripes appear in copied or transmitted images.
	White sheet unit	When copied or transmitted images are light.
	Transfer guide (upper and lower)	When dirty.

Level	Location	When
Service technician	Multi-purpose tray pick-up roller	When recording paper pick-up performance fails.
	Cassette pick-up roller	When recording paper pick-up performance fails.
	Cassette separation roller	When recording paper separation or feed performance fails. When marks at intervals of 2.97" (75 mm).
	Cassette feed roller	When recording paper feed performance fails. When marks on back of recording paper at intervals of 2.97" (75 mm).
	Separation pad	When recording paper separation performance fails.
	Feed roller	When recording paper feed performance fails. When marks on back of recording paper at intervals of 1.97" (50 mm).
	Pre-transfer roller	When recording paper feed performance fails. When marks on back of recording paper at intervals of 1.97" (50 mm).
	Registration arm	When marks on recording paper.
	Transfer guide (upper and lower)	When marks, or marks on back of recording paper.
	Transfer charging roller	When marks on back of recording paper or blank spots at intervals of 1.85" (47 mm) in copied or received images.
	Paper feed belt	When marks on back of recording paper.
	Paper feed guide	When marks on back of recording paper.
	Fixing entrance guide	When marks, marks on back of recording paper, irregular/smudged black vertical line, paper jam, or wrinkles in copied or received images.
Fixing film	When marks at intervals of 2.95" (75 mm) or poor fixing in printed-out.	

Level	Location	When
	Fixing pressure roller	When marks on back of recording paper at intervals of 2.48" (63 mm), poor fixing, paper jam, or wrinkles in printed-out.
	Fixing eject roller	When recording paper jam.
	Face-up deflector	When recording paper jam.
	Lower paper delivery guide	When recording paper jam.

1.1.3 Periodic inspections

Level	Location	When
User	None	—
Service technician	None	—

1.1.4 Periodic replacement parts

Level	Location	When
User	None	—
Service technician	None	—

1.2 Tools

1.2.1 General tools

Tool	Use
Phillips screwdriver	Removing/inserting screws
Slot head screwdriver	Removing/inserting screws
Precision phillips screwdriver	Adjust volume
Precision slot head screwdriver	Removing plastic tabs
Tweezers	Removing/inserting coil springs
Pliers, needle nose	Attaching retaining ring
Digital volt meter	Check voltage
Lint-free paper	Clean transfer charging roller, fixing film
Isopropyl alcohol	Clean fixing film, fixing entrance guide, fixing pressure roller, fixing eject roller, face-up deflector, static charge eliminator, etc.
Ruler	Measure leading edge margin of print image

1.2.2 Special tools

Tool	Use	Part No.
Grease (TELLUS OIL 68)	Apply to specified parts	CK-8003
Grease (MOLYKOTE EM-50L)	Apply to specified parts	HY9-0007
Grease (FLOIL GE676)	Apply to specified parts	CK-0544
Printer driver tester	Check operation of the printer and options.	RY9-0124
Thickness gauge (1.6mm)	Used for installing the separation guide of the optional envelope feeder.	RY9-0123
Thickness gauge (0.7mm)	Used with the printer driver tester to adjust installation position of the envelope multiple feed sensor of the envelope feeder.	RY9-0122
IC-Removing Tool (24~64pin)	Remove the main ROM on the SCNT board	HY9-0022

2. CONSUMABLES REPLACEMENT

2.1 Toner Cartridge



REFERENCE

For details on how to replace the toner cartridge, see *Chapter 5: 1.4 Assembling the Fax*.

2.2 Recording Paper



REFERENCE

For details on how to refill the paper, see *Chapter 5, 1.4 Assembling the Fax*.

2.3 Stamp Ink

1. Disconnect the power cord of the fax unit from its power source.
2. Lift the document feeder tray, and gently open the ADF cover until it stops, grasping the document feeder tray and the ADF cover at the same time.

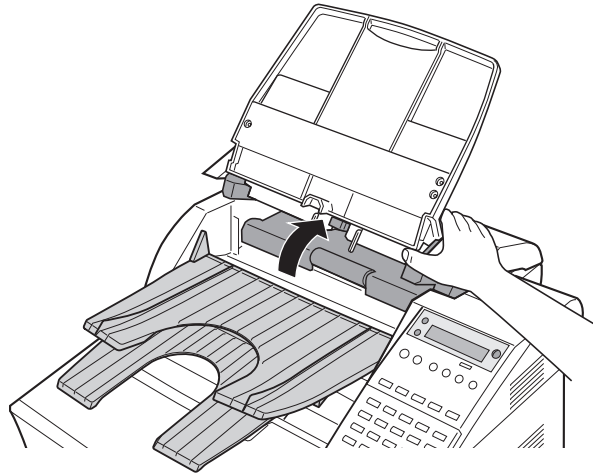

3. While holding the ADF cover open with one hand, use one finger of your other hand to gently push in the black plastic loop to separate it from the stub on the fax machine.

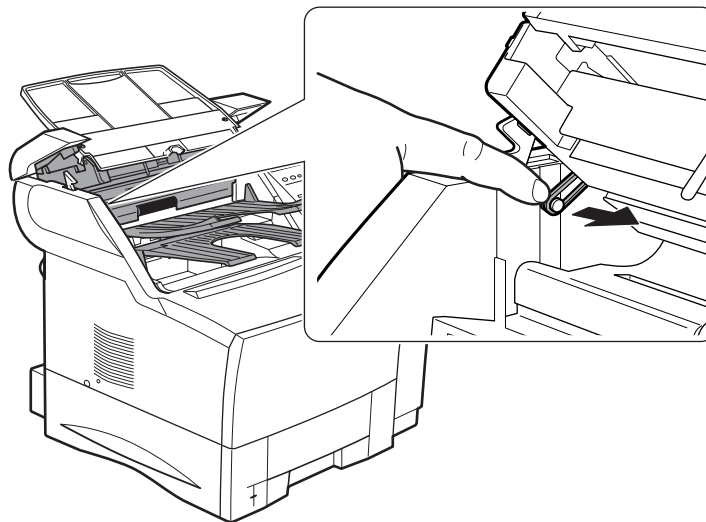

Figure 4-1 Refilling the Stamp Ink 1

4. Gently lift the ADF cover up to the full open position.

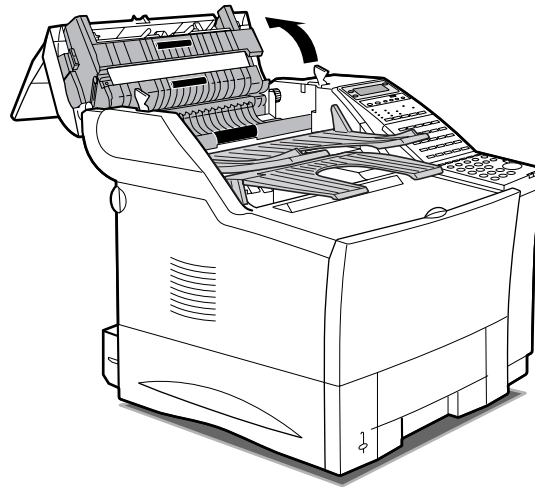

Figure 4-2 Refilling the Stamp Ink 2

5. Locate the stamp pad then apply only one drop of ink to the stamp ink compartment.
 - To avoid a malfunction, do not add too much ink.
 - Use only Shachihata X Stamper Ink CS-20 Yellow.
 - Do not use the stamp feature for at least one hour. If you have to send a document, turn off the stamp feature for the first hour.

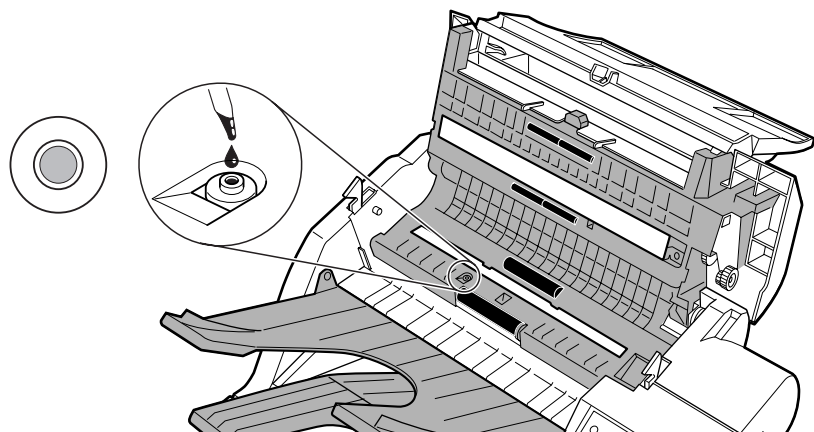

Figure 4-3 Refilling the Stamp Ink 3



TO AVOID INK SPILLAGE, APPLY ONLY ONE DROP OF INK TO THE STAMP PAD.

6. Close the ADF cover, lower the document feeder tray, and connect the power cord of the fax unit to the power source.



Note

-
- Make sure that you do not drip ink on any other part of the fax.
 - Make sure that you put the plastic loop back in place when you close the ADF cover.
-

3. CLEANING

3.1 Main Unit

Wipe any dirt off with a soft, dry cloth.

3.2 Document Pick-up Roller

Open the upper reader frame unit and wipe any dirt off with a soft, dry cloth.

3.3 Separation Roller (Upper)

Open the upper reader frame unit and wipe any dirt off with a soft, dry cloth.

3.4 Separation Roller (Lower)

Open the upper reader frame unit and wipe any dirt off with a soft, dry cloth.

3.5 Scanning Glass (Contact Sensor)

Open the middle reader frame unit and wipe any dirt off with a soft, dry cloth.

3.6 White Sheet

Open the middle reader frame unit and wipe any dirt off with a soft, dry cloth.

3.7 Document Feed Roller 1

Open the upper reader frame unit and wipe any dirt off with a soft, dry cloth.

3.8 Document Feed Roller 2

Open the middle reader frame unit and wipe any dirt off with a soft, dry cloth.

3.9 Document Eject Roller

Open the middle reader frame unit and wipe any dirt off with a soft, dry cloth.

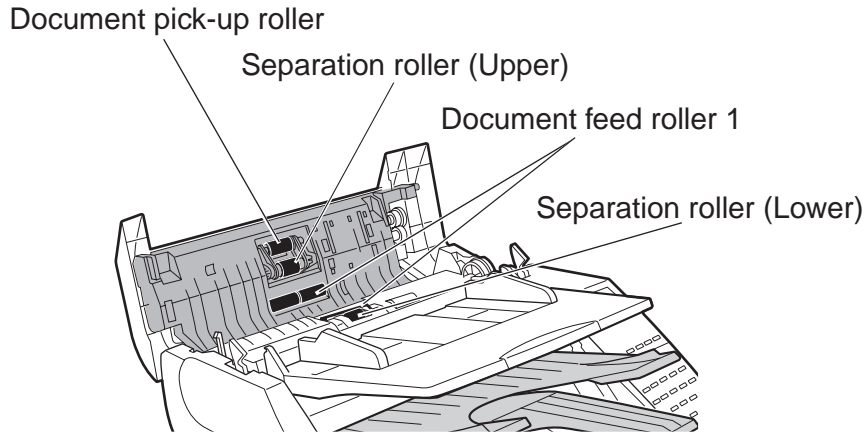

Figure 4-4 Cleaning Location 1

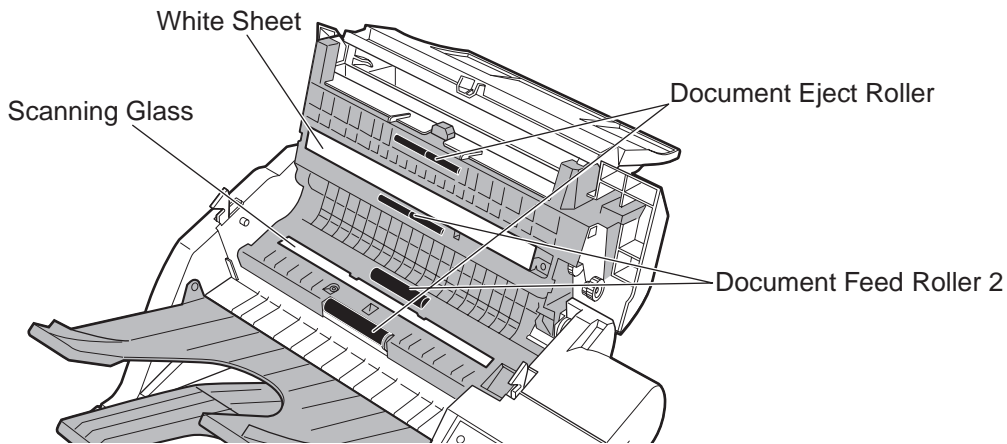

Figure 4-5 Cleaning Location 2



Do not use tissue. Otherwise, paper dust may stick to the parts or a static charge may be generated.



NOTE

In cases where there is a lot of dirt in item 3.1, polish with a cloth after wiping off the dirt with a cloth wet with water and wrung out.

In cases where there is a lot of dirt in items 3.2 to 3.9, wipe with a cloth dampened with isopropyl alcohol.

3.10 Transfer Guide

a) Preparations for cleaning

- (1) Disconnect the power cord of the fax from the power source.
- (2) Lift the document feeder tray, the document output tray and the upper output tray.

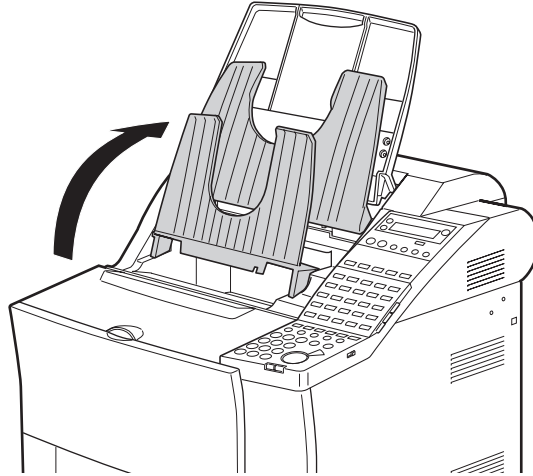

Figure 4-6 Preparation for Cleaning 1

- (3) Open the printer cover and remove the toner cartridge.
Store the cartridge in its original protective bag to avoid exposure to light.

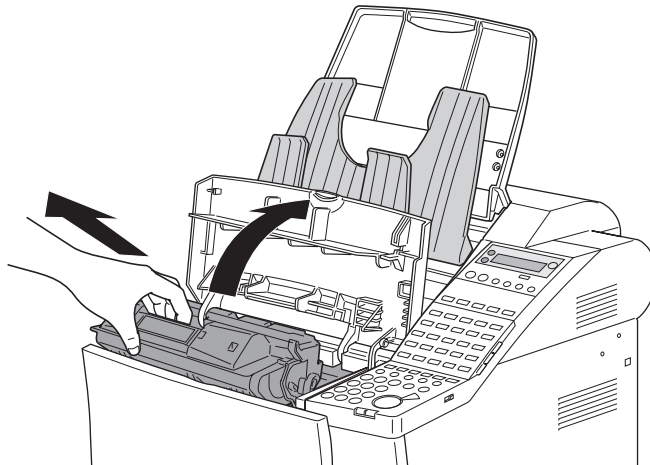

Figure 4-7 Preparation for Cleaning 2

b) Cleaning

- (1) Using a soft clean cloth, wipe any paper dust off the black plate of the transfer guide.

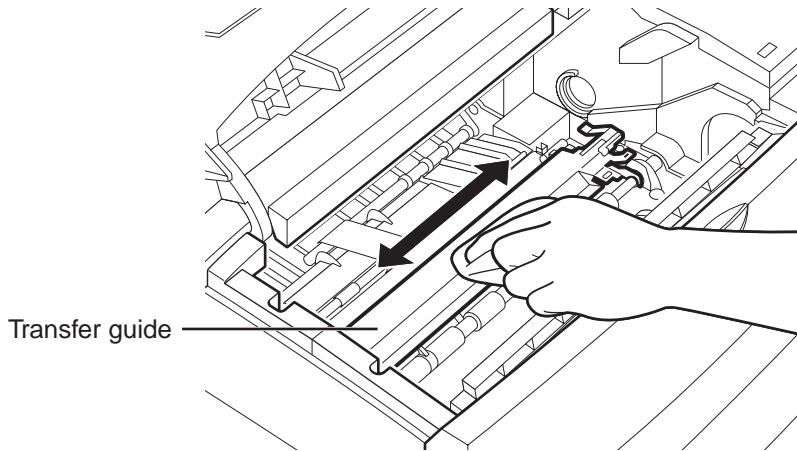

Figure 4-8 Cleaning Location 1

- (2) While holding the green lever, flip the transfer guide up. Wipe the edge of the transfer guide with a soft, clean cloth, to remove toner and paper dust from both sides of the transfer guide.

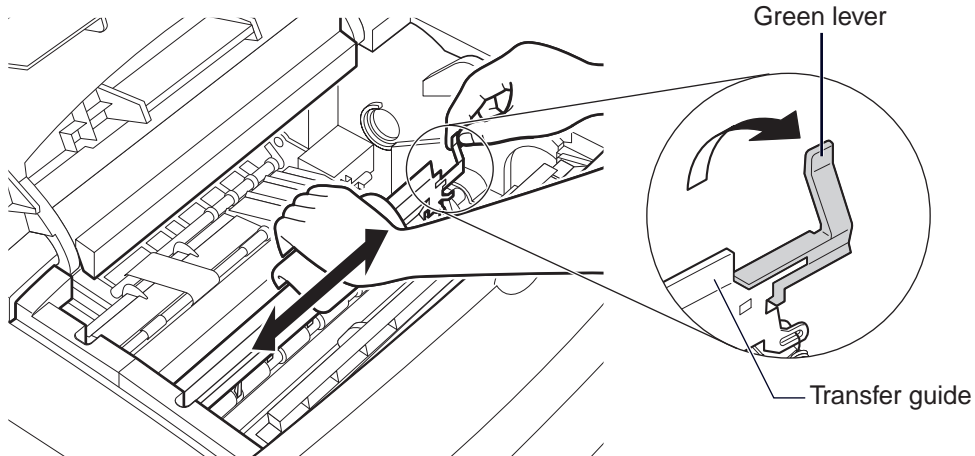

Figure 4-9 Cleaning Location 2

- (3) Pull the transfer guide back to its full extent, then wipe the silver metal strip with cloth. Then gently guide the transfer guide back to its original position.

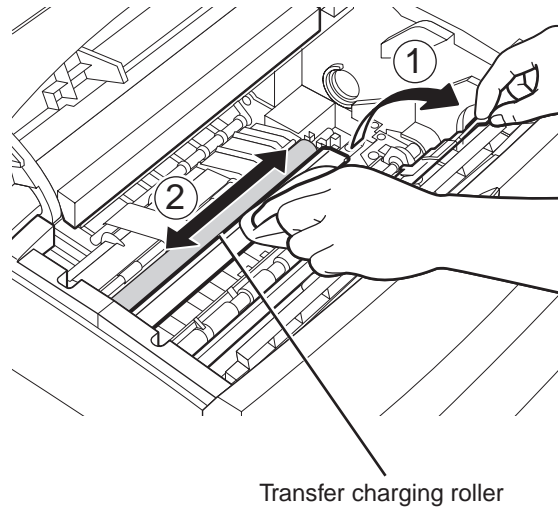

Figure 4-10 Cleaning Location 3



NOTE

The spring for the transfer guide is strong. Always guide the transfer guide slowly back to its original position by holding the green lever. Never let it jump back by releasing the lever.

To avoid deterioration in print quality, never touch the transfer charging roller when clean the metal strip.

3.11 Transfer Charging Roller

a) Preparations for cleaning

- (1) Disconnect the power cord of the fax from the power source.
- (2) Lift the document feeder tray, the document output tray and the upper output tray.
- (3) Open the printer cover and remove the toner cartridge.
Store the cartridge in its original protective bag to avoid exposure to light.
- (4) Raise the left-most end of the transfer charging roller shaft clear of the transfer roller mount (right side) using the precision slot head screwdriver.
- (5) Remove the transfer charging roller.

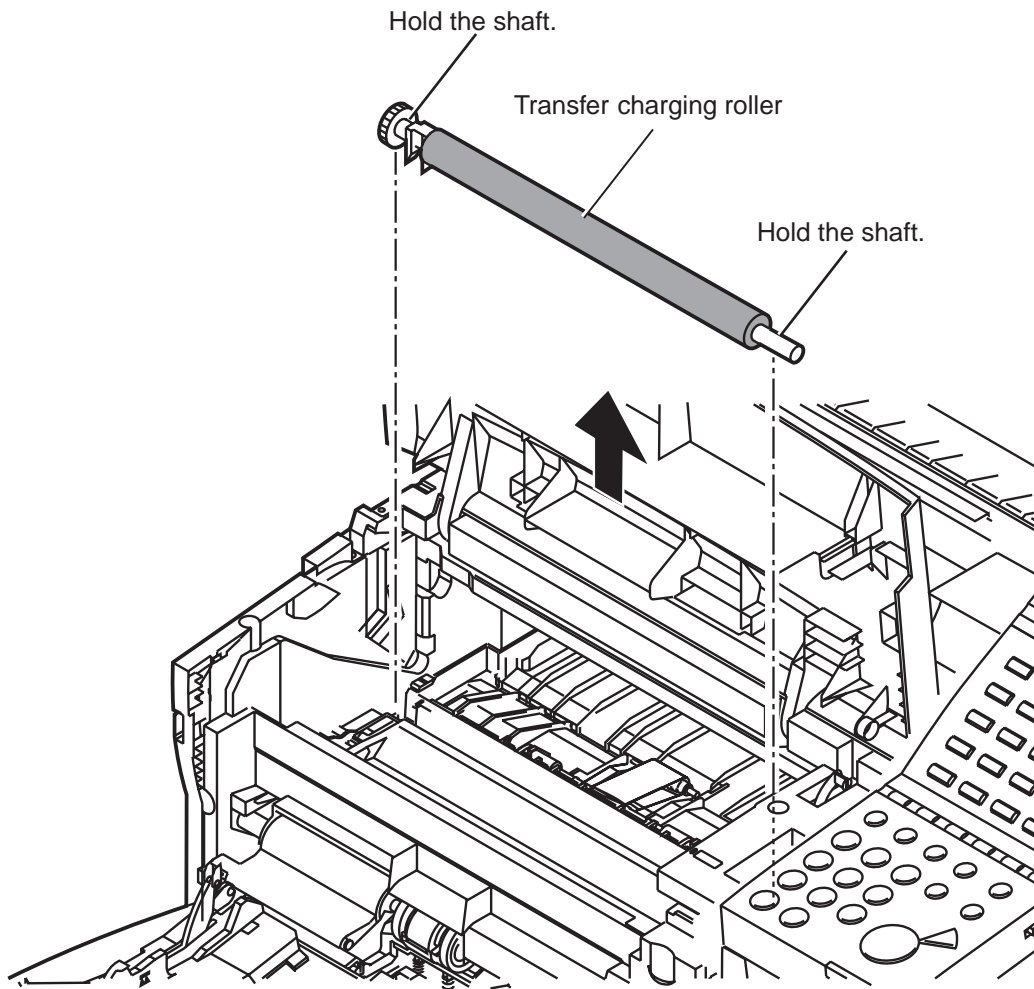

Figure 4-11 Preparation for Cleaning

b) Cleaning

(1) Using lint-free paper, wipe any dirt off the transfer charging roller.

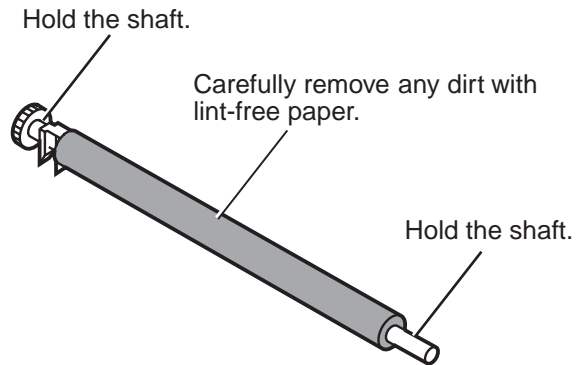

Figure 4-12 Cleaning Location



NOTE

Do not touch or hold the rubber section of the transfer charging roller. Doing so can cause marks on back of paper or blank spots in copied or received images.

Never clean with solvents!

If lint-free paper can not fully clean the transfer charging roller or if the roller is deformed, replace it.

3.12 Cassette Pick-Up Roller/Feed Roller/Separation Roller

a) Preparations for cleaning

- (1) Disconnect the power cord of the fax from the power source.
- (2) Disconnect the telephone line modular jack cord.
- (3) Remove the document feeder tray, the document output tray, the upper output tray and the cassettes.
- (4) Open the printer cover and remove the toner cartridge.
Store the cartridge in its original protective bag to avoid exposure to light.
- (5) If a paper feed unit PF-52 is installed, remove the option. If it is not installed, go to the step (6).

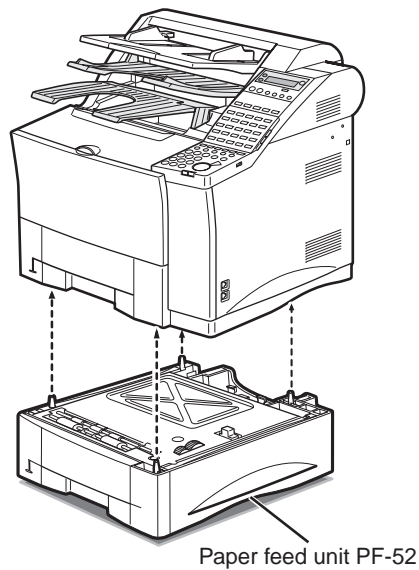

Figure 4-13 Preparation for Cleaning 1

- (6) Turn the main unit over to the side, so that its right side faces down.

Open the panels to avoid the broken.

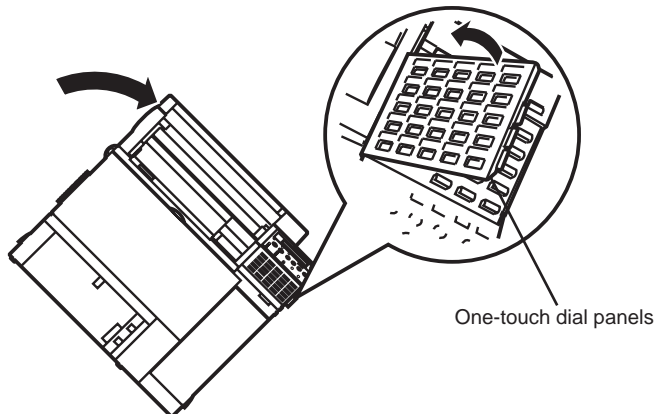

Figure 4-14 Preparation for Cleaning 2



NOTE

To avoid broken the one-touch dial panels, keep open the panels.

b) Cleaning

- (1) Using lint-free paper dipped in alcohol, wipe any dirt off the cassette pick-up roller and the cassette feed roller while rotating the shaft in the indicated direction.

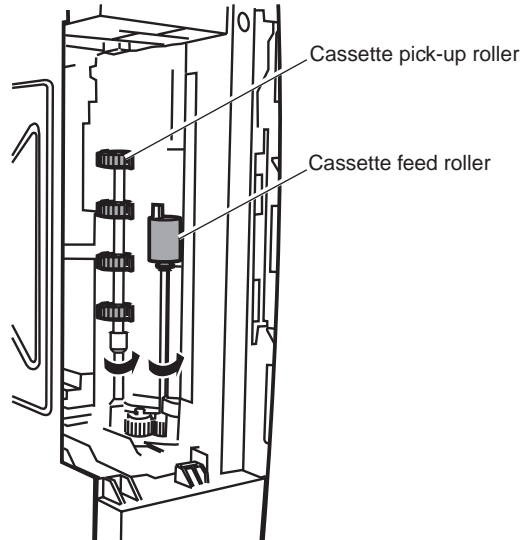

Figure 4-15 Cleaning Location 1

- (2) If a paper feed unit PF-52 is installed, cleaning the option by the same way in the above step (1).
- (3) Using lint-free paper dipped in alcohol, wipe any dirt off the cassette separation roller while rotating the shaft in the indicated direction.

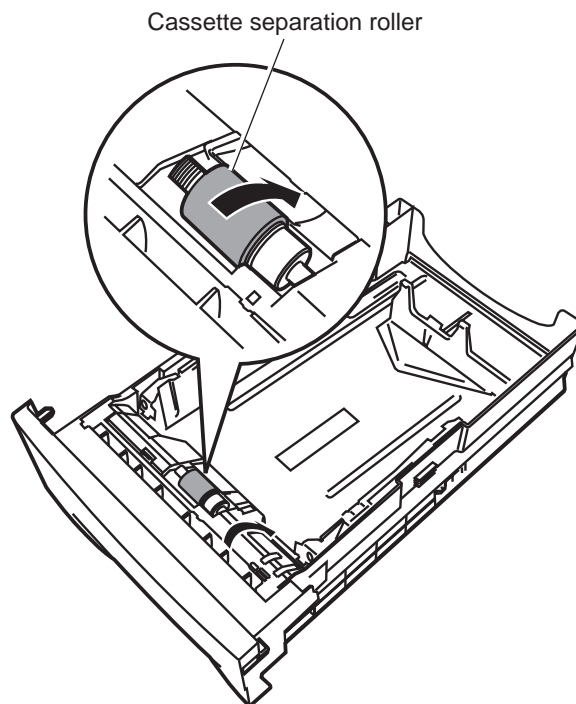

Figure 4-16 Cleaning Location 2

3.13 Multi-Purpose Tray Pick-Up Roller/Separation Pad

a) Preparations for cleaning

- (1) Disconnect the power cord of the fax from the power source.
- (2) Open the multi-purpose tray.
- (3) Remove the entrance cover.

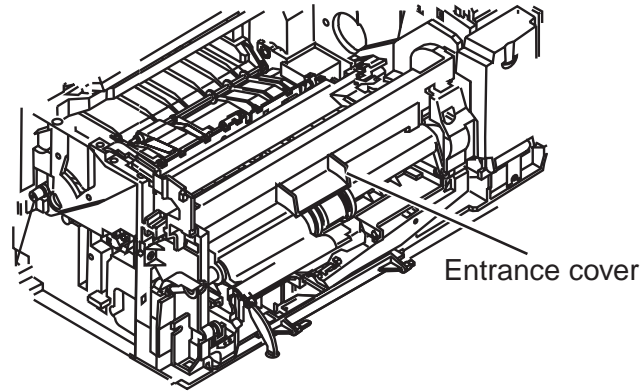

Figure 4-17 Preparation for Cleaning 1

- (4) Remove the multi-purpose tray pick-up roller, after release the claw with rotating the slot head screw driver.

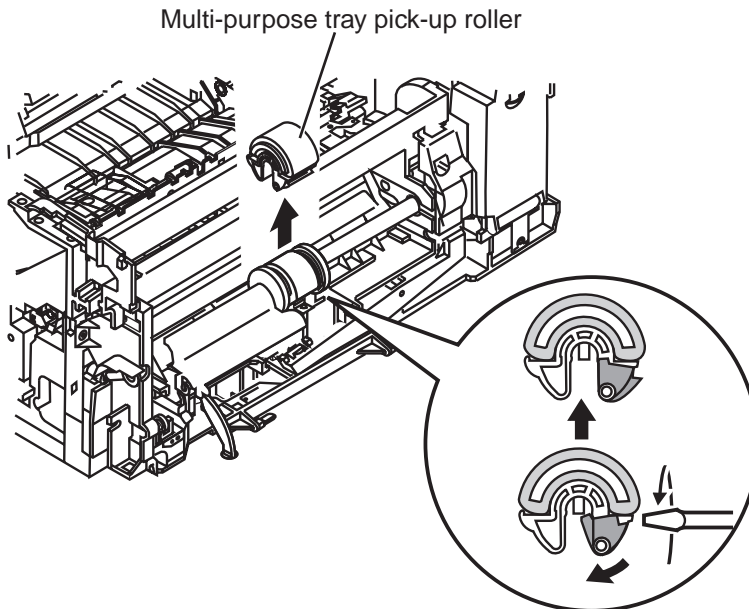

Figure 4-18 Preparation for Cleaning 2

b) Cleaning

- (1) Using lint-free paper dipped in alcohol, wipe any dirt off the multi-purpose tray pick-up roller.

Multi-purpose tray pick-up roller



Figure 4-19 Cleaning Location 1

- (2) Using lint-free paper dipped in alcohol, wipe any dirt off the multi-purpose tray separation pad.

Slide the support roller
for easy to clean.

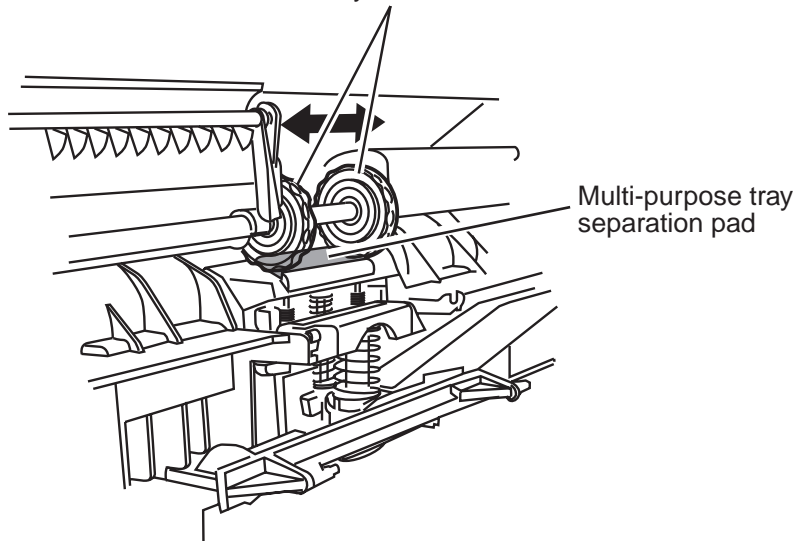

Figure 4-20 Cleaning Location 2

3.14 Feed Roller

a) Preparations for cleaning

- (1) Disconnect the power cord of the fax from the power source.
- (2) While holding the upper reader frame and the middle reader frame open with one hand, use one finger of your other hand to gently push in the stopper to separate it from the stub on the fax machine, and open the upper reader frame and the middle reader frame.

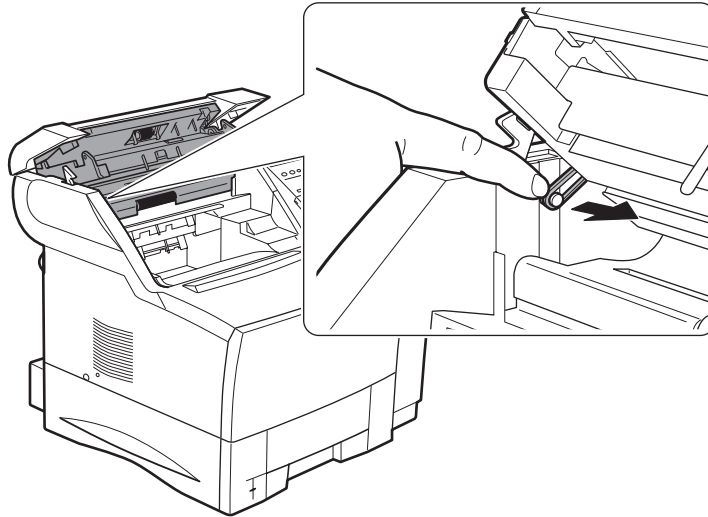

Figure 4-21 Preparation for Cleaning 1

- (3) Remove the two screws, release the claw of the left cover using the slot head screw driver, open the top side, and pull the left cover up to remove.

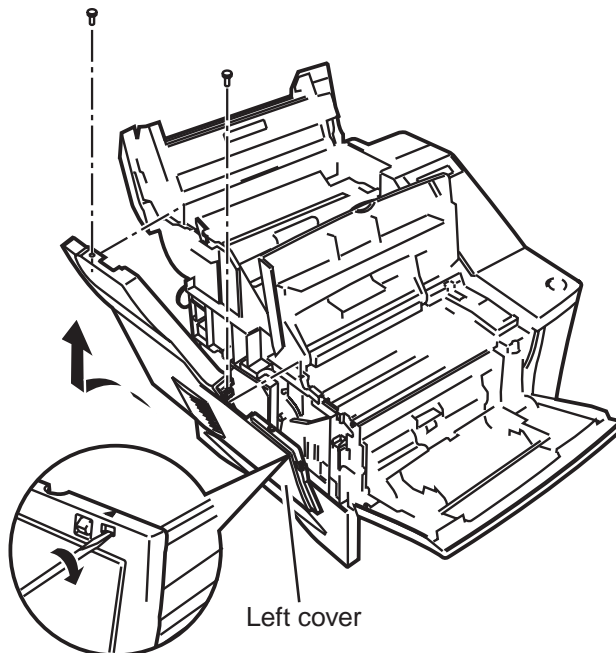

Figure 4-22 Preparation for Cleaning 2

- (4) Remove the right cover, front right cover, rear cover and the read motor cover.
- (5) Remove the joint of the printer cover using the needle nose prier and release the claw using the precision slot head screw driver. Then, remove the printer cover.

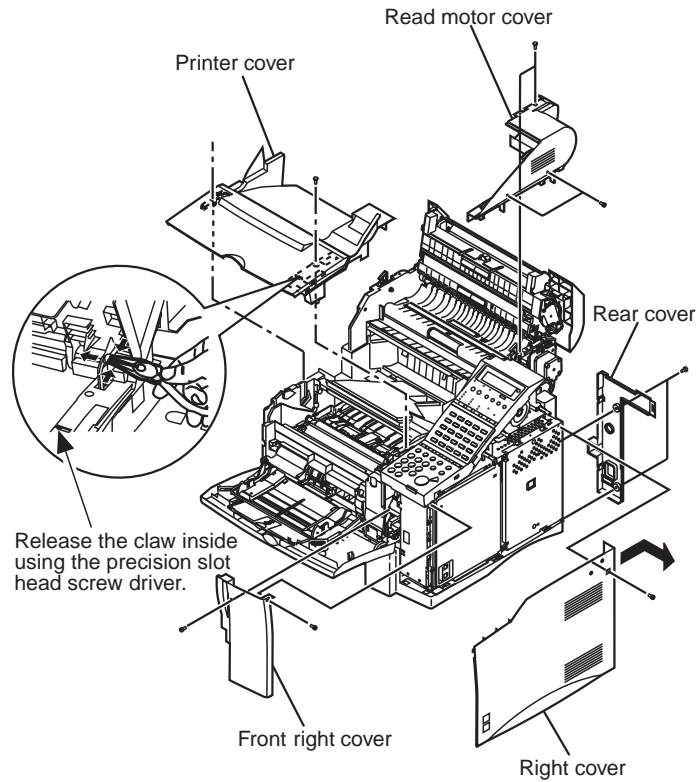

Figure 4-23 Preparation for Cleaning 3

- (6) Remove the claw of the multi-purpose tray.
- (7) Separate the multi-purpose tray from the front cover.
- (8) Remove the front cover by shifting it to the right.
- (9) Remove the multi-purpose tray.

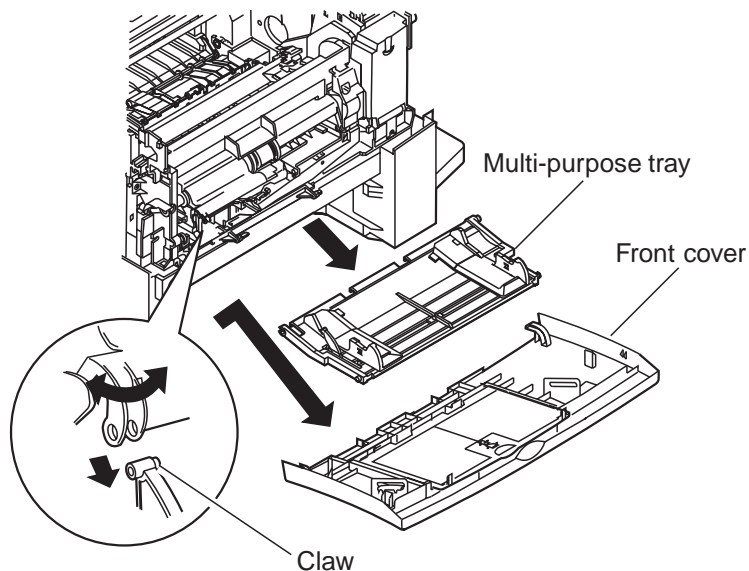

Figure 4-24 Preparation for Cleaning 4

(10) Remove the shield cover and the operation panel.

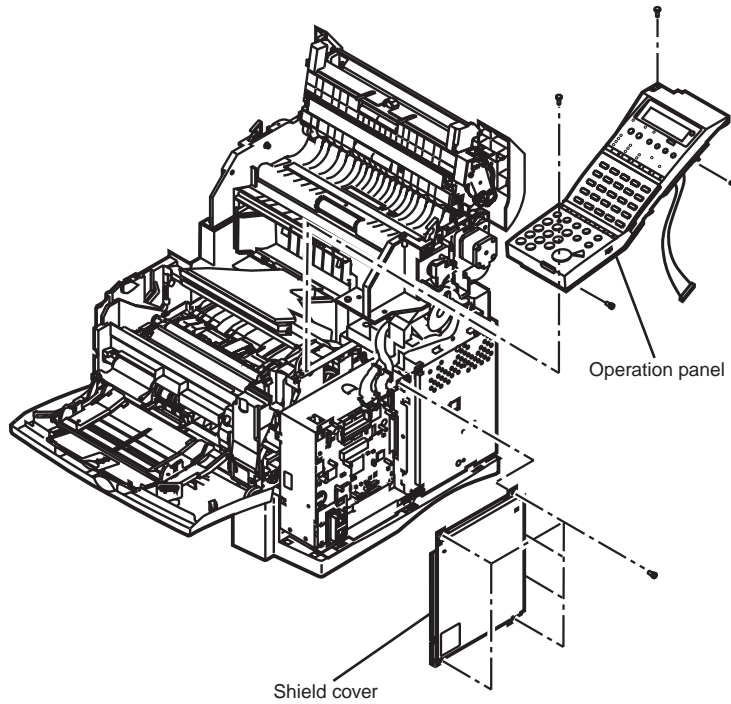

Figure 4-25 Preparation for Cleaning 5

(11) Remove the PCBs and the metal frame. Then, disconnect the solenoid connector.

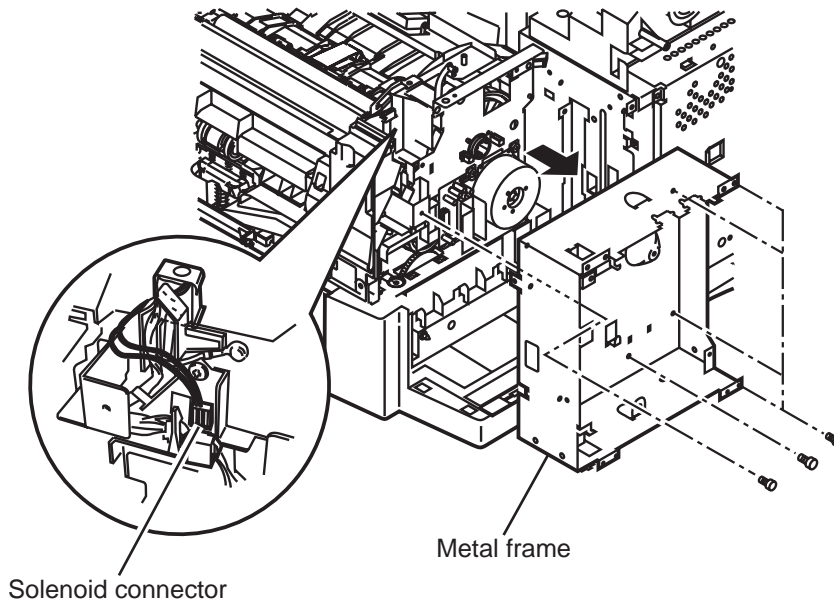

Figure 4-26 Preparation for Cleaning 6

- (12) Remove the entrance cover.
- (13) Disconnect the multi-purpose paper sensor cable.

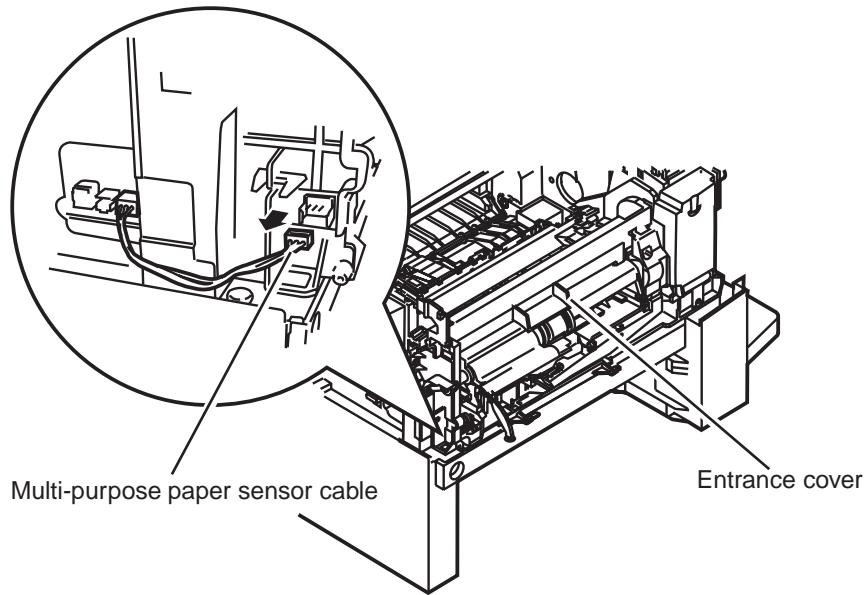

Figure 4-27 Preparation for Cleaning 7

- (14) Remove the two long screws.
- (15) Remove the one screw of the envelope feeder gear cover. Then, push the claw from the inside and remove the envelope feeder gear cover.
- (16) Remove the multi-purpose pick-up ass'y.

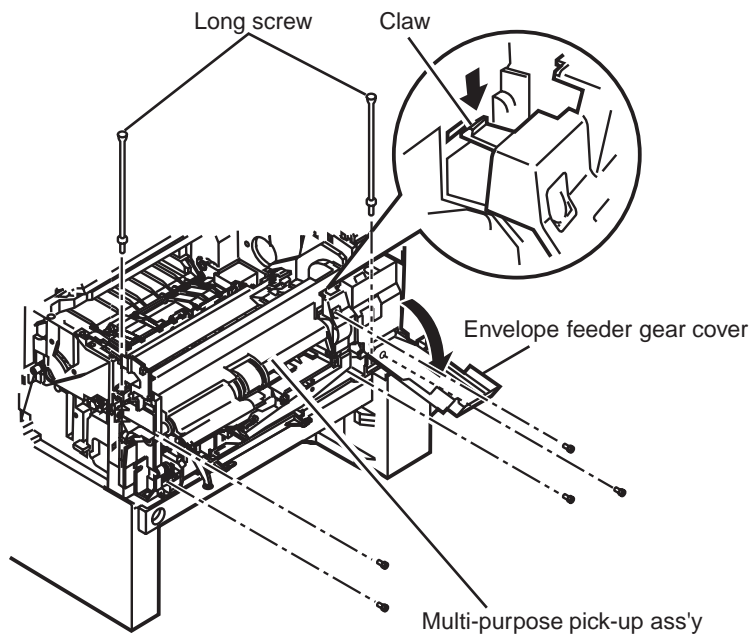

Figure 4-28 Preparation for Cleaning 8

b) Cleaning

- (1) After removing the envelope feeder gear cover and the multi-purpose pick-up ass'y, using lint-free paper dipped in alcohol, wipe any dirt off the feed roller while rotating the gear.

The gears should always be greased. If the grease is lost, reapply to them.

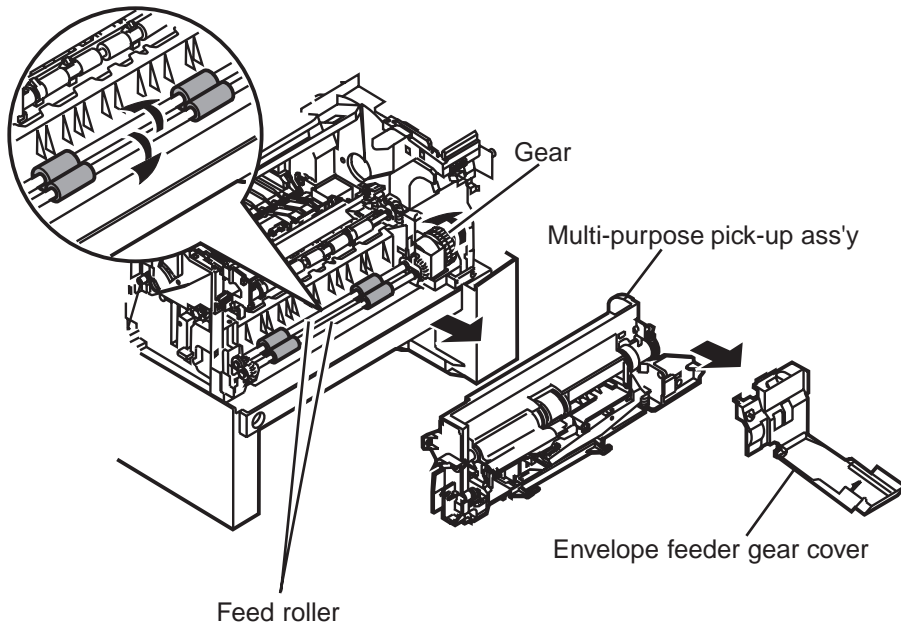

Figure 4-29 Cleaning Location

3.15 Pre-Transfer Roller and Registration Arm

a) Preparations for cleaning

- (1) Refer to 3.14 *Feed Roller* to remove the envelope feeder gear cover and the multi-purpose pick-up ass'y.
- (2) Remove the six screws.

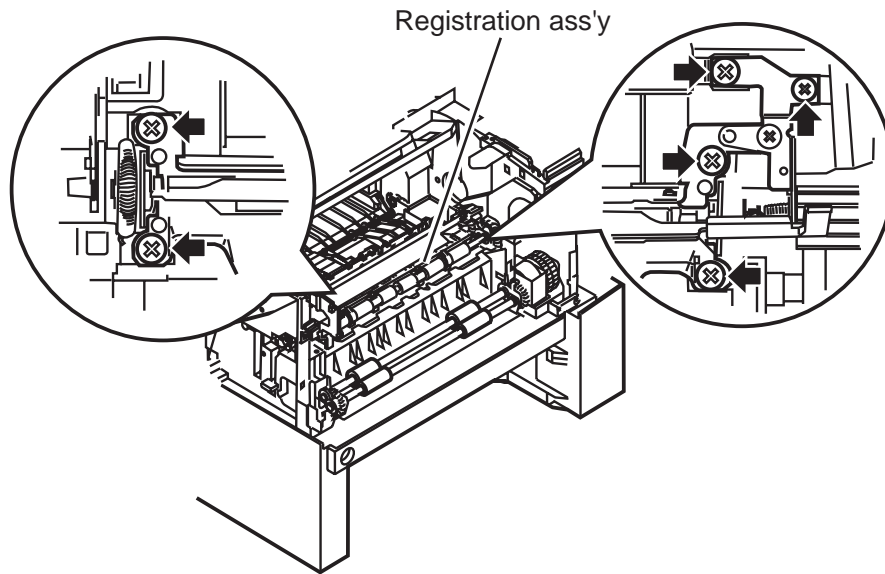

Figure 4-30 Preparation for Cleaning 1

- (3) Remove the front inner cover ass'y.
- (4) Remove the registration ass'y.

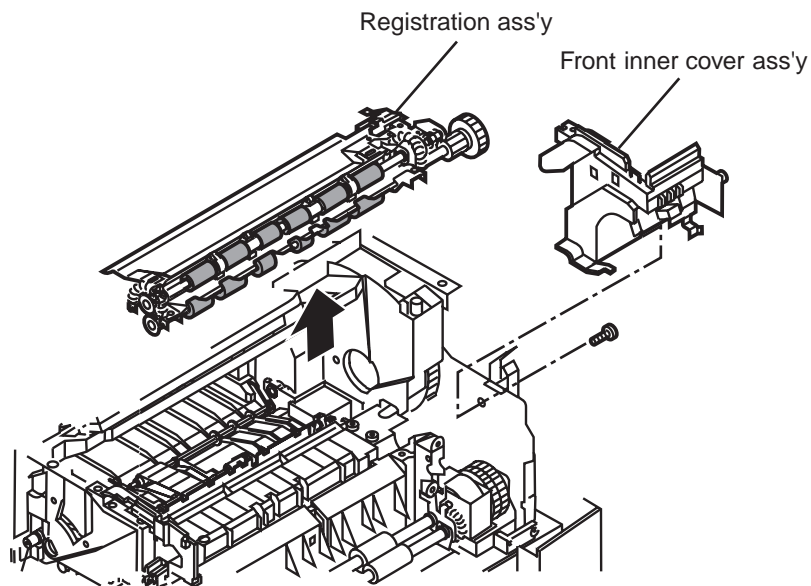

Figure 4-31 Preparation for Cleaning 2

b) Cleaning

- (1) Using lint-free paper dipped in alcohol, wipe any dirt off the pre-transfer roller and registration arm.

The gear should always be greased. If the grease is lost, reapply to it.

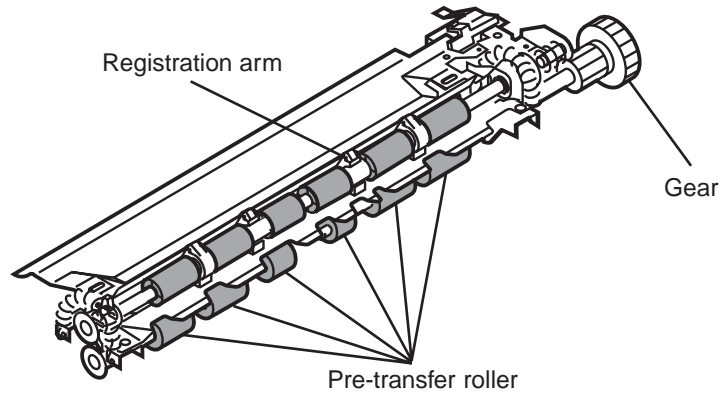

Figure 4-32 Cleaning Location

3.16 Paper Feed Belt and Paper Feed Guide

a) Preparations for cleaning

- (1) Refer to 3.11 *Transfer Charging Roller* to remove the transfer charging roller.
- (2) Remove the paper feed roller using the precision slot head screwdriver.



NOTE

When removing the paper feed roller, do not make contact with the static charge eliminator.

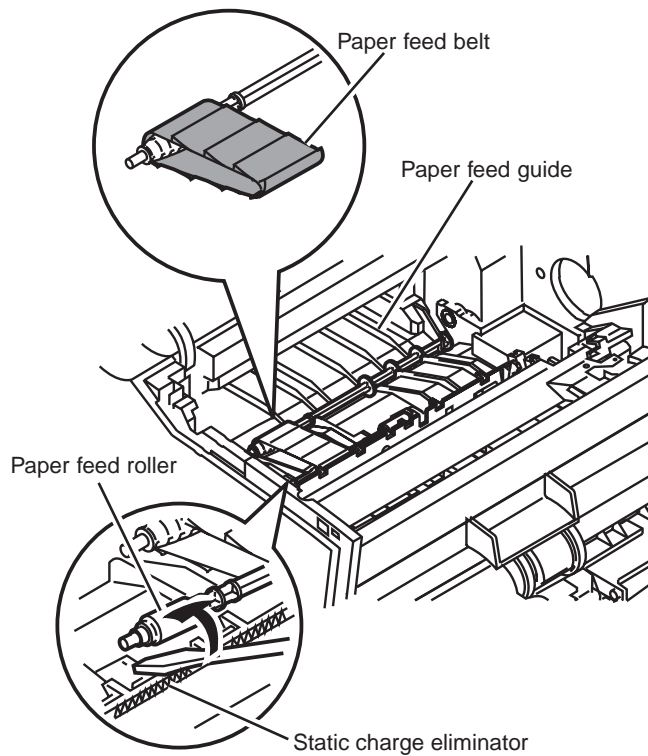

Figure 4-33 Preparation for Cleaning

b) Cleaning

- (1) Using lint-free paper dipped in alcohol, wipe any dirt off the paper feed belt rotating it.

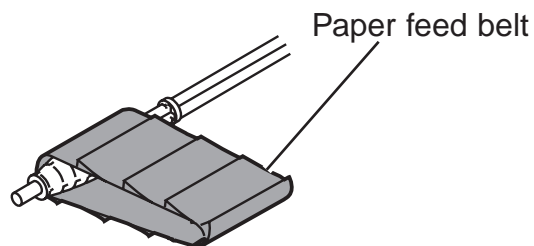

Figure 4-34 Cleaning Location 1

(2) Using lint-free paper dipped in alcohol, wipe any dirt off the paper feed guide.

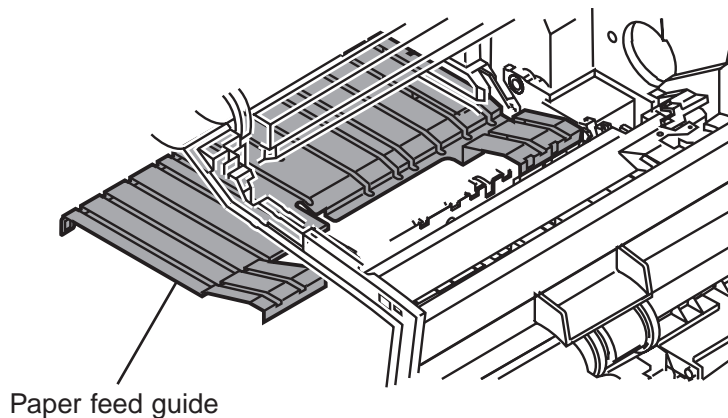

Figure 4-35 Cleaning Location 2

3.17 Fixing Unit Entrance Guide

a) Preparations for cleaning

- (1) Disconnect the power cord of the fax from the power source.
- (2) Remove the right rear cover and the left rear cover.
- (3) Remove the face-up tray.
- (4) Loose the two screws and remove the fixing ass'y.

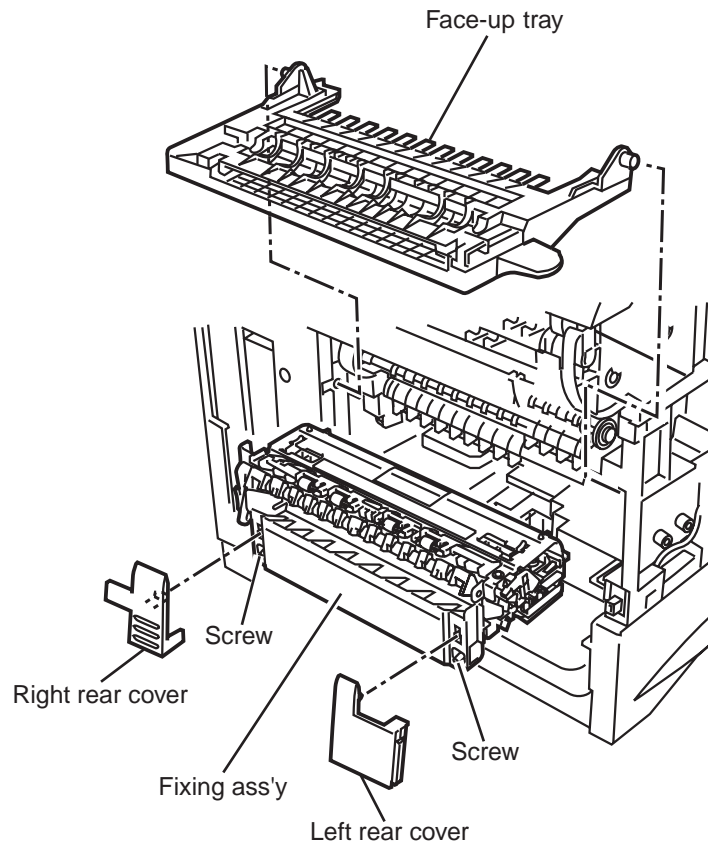

Figure 4-36 Preparation for Cleaning

b) Cleaning

- (1) Using lint-free paper dipped in alcohol, wipe any dirt off the fixing entrance guide.

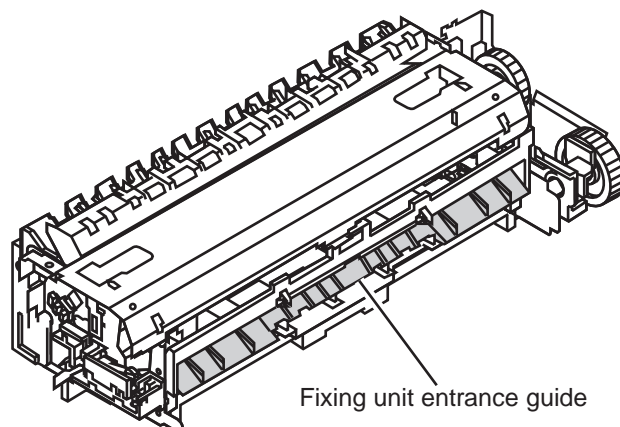

Figure 4-37 Cleaning Location

3.18 Fixing Film

a) Preparations for cleaning

- (1) Disconnect the power cord of the fax from the power source.
- (2) Refer to 3.17 *Fixing Unit Entrance Guide* to remove the fixing ass'y.
- (3) While pushing the claw, remove the left fixing ass'y connector.

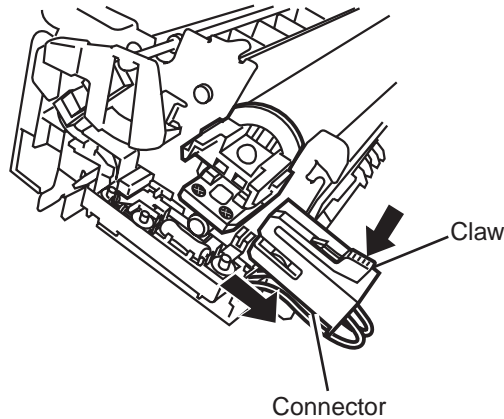

Figure 4-38 Preparation for Cleaning 1



NOTE

When remove the connector, be careful not to scratch the cable with the edge of metal chassis.

- (4) Turn the fixing ass'y over, and remove the connector from the other end while pushing the claw.

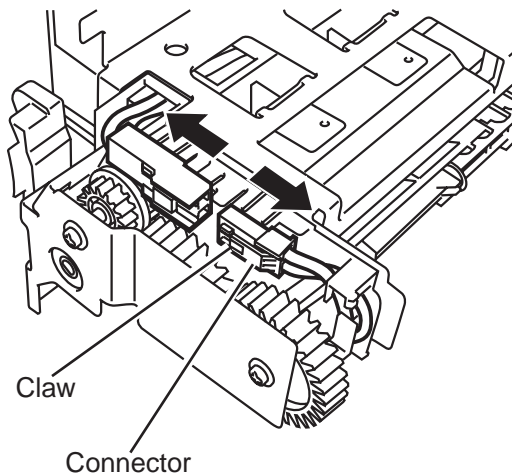

Figure 4-39 Preparation for Cleaning 2



NOTE

When remove the connector, be careful not to scratch the cable with the edge of metal chassis.

(4) Remove the upper crossmember.

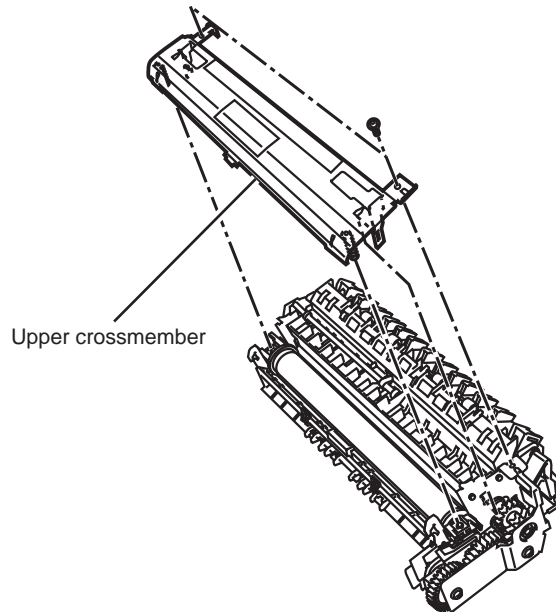

Figure 4-40 Preparation for Cleaning 3

b) Cleaning

(1) Using lint-free paper, wipe any dirt off the fixing film.

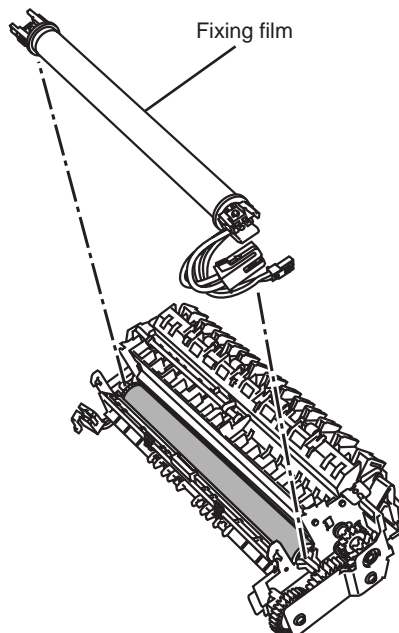

Figure 4-41 Cleaning Location



NOTE

When cleaning, be careful not to touch the fixing film.

3.19 Face-Up Deflector, Fixing Delivery Roller and Lower Paper Delivery Guide

a) Preparations for cleaning

- (1) Disconnect the power cord of the fax from the power source.
- (2) Refer to the Figure 4-36, 4-37 and 4-40 to remove the upper crossmember.
- (3) Remove the upper paper guide ass'y.

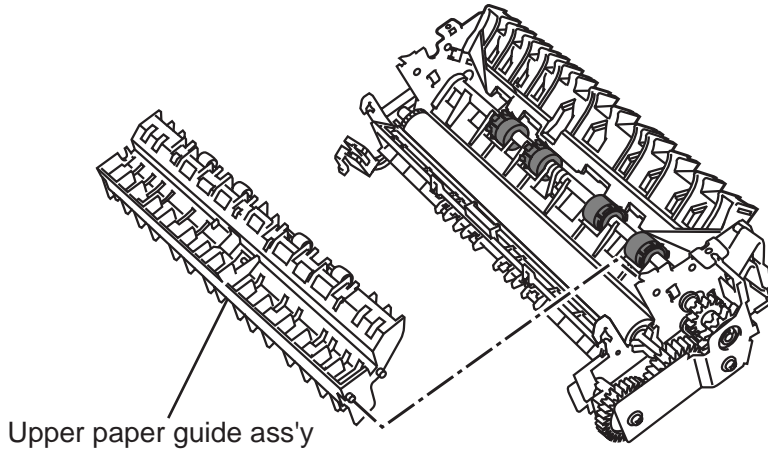

Figure 4-42 Preparation for Cleaning

b) Cleaning

- (1) Using lint-free paper dipped in alcohol, wipe any dirt off the face-up deflector, fixing delivery roller and lower paper delivery guide.
The gears should always be greased. If the grease is lost, reapply grease to them.

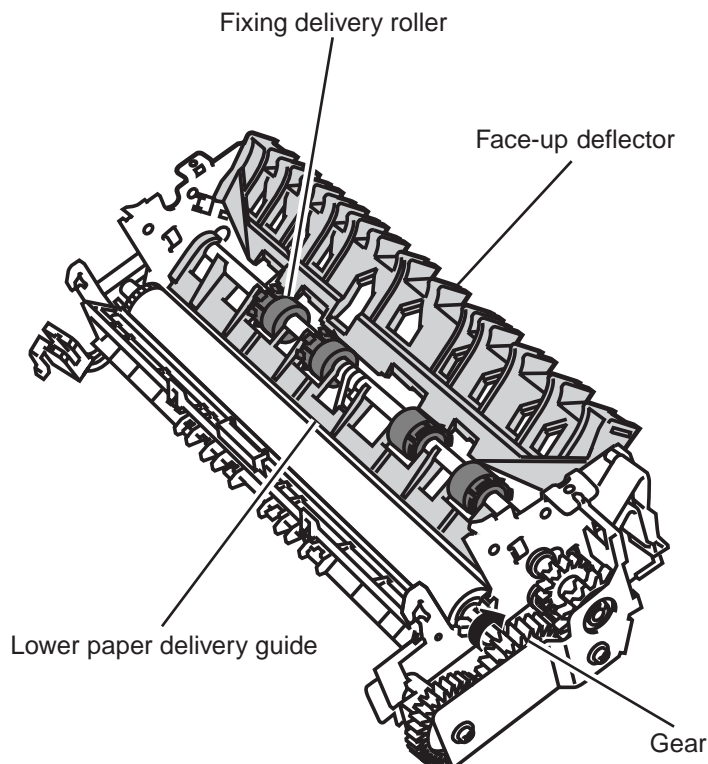

Figure 4-43 Cleaning Location

4. ADJUSTMENT

4.1 Parts Replacement

Please refer to the separate *PARTS CATALOG* for disassembly / assembly procedures to follow when replacing parts. The *PARTS CATALOG* shows illustrations which follow the disassembly procedures. Additionally, there are enlarged and special-help illustrations for parts which require caution during disassembly and assembly. Also, the notes of caution written in the illustrations are items where special caution is necessary.

4.2 Points to Grease

There are parts which have grease applied to make their operation smooth and to increase electrical conductivity. Apply grease when replacing parts where grease is applied or when grease has come off.

Please refer to the separate *PARTS CATALOG* regarding locations to apply grease.

4.3 Adjustment items

This fax requires the following adjustments.

Item	When
Leading edge margin	When the ECNT board or the laser/scanner unit is replaced.

4.4 Leading Edge Margin Adjustment

a) When

As VR501 on the ECNT board is adjusted at the factory, its adjustment at the time of installation is not required.

However, when the ECNT board is replaced in the field, the leading edge margin needs to be readjusted. Also, if the leading edge margin of test prints made after laser/scanner unit replacement is not 2.0mm, this adjustment is necessary. The adjustment procedures are shown below.

b) Tools

Tool	Use
Phillips screwdriver	Removing/inserting screws
Precision phillips screwdriver	Adjusting volume
Ruler	Measuring leading edge margin of printed image

c) Adjustment

c-1) Preparations

- (1) Open the printer cover and the upper reader frame unit.
- (2) Remove the left cover.
- (3) Set letter or A4 size recording paper in the cassette.
- (4) Close the printer cover and the upper reader frame unit.

c-2) Adjustment

- (1) Disconnect the power cord.
- (2) After setting the VR501 to the center position (+/-0) on the ECNT board, set the paper in the cassette.
- (3) Connect the power cord.
- (4) Press the test print switch (SW501) to make several test prints.



NOTE

When a test print is performed, the Error lamp blinks and “CHECK PRINTER” is displayed.

- (5) Measure the length (leading edge margin) from the leading edge to the print pattern. Measure all the test prints and calculate their average.
- (6) Adjust VR501 so that the calculated value in step (5) becomes 2.0mm. The pattern image shifts in the “+” direction if VR501 is turned clockwise, and in the “-” direction, counterclockwise. Turning the VR501 one scale shifts the pattern about 0.6mm. For instance, if the average value calculated in step (5) is 1.4mm, the difference is 0.6mm. Therefore, turn VR501 clockwise for one scale.

- (7) Make several test prints again, and perform step (5). Check that the leading edge margin is 2.0mm.
If the value is incorrect, repeat steps (4) to (7).

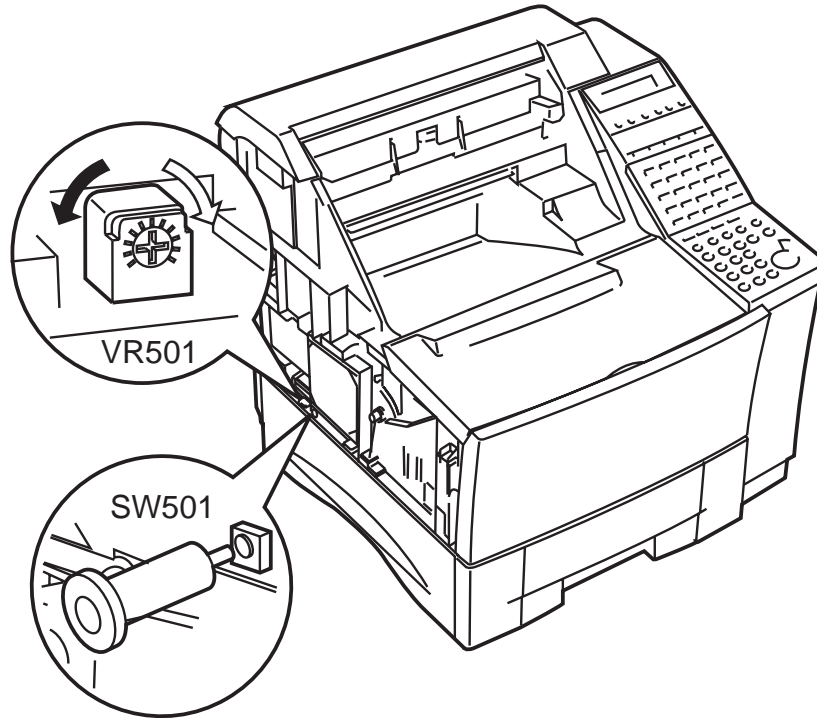

Clockwise

Turning one scale increases the leading edge margin approx. 0.02" (0.6 mm).

Counterclockwise

Turning one scale decreases the leading edge margin approx 0.02" (0.6 mm).

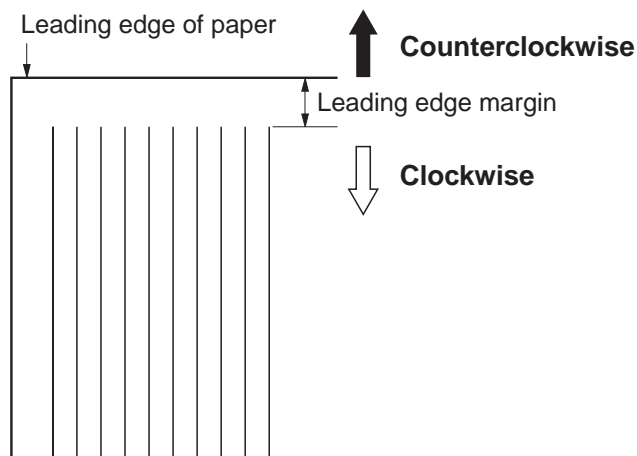

Figure 4-44 Leading Edge Margin Adjustment

5. TROUBLESHOOTING

5.1 Troubleshooting

5.1.1 Repairs

a) Check installation environment

Check that the following conditions have been met with regard to installation environment.

- (1) This fax must be installed on a level surface.
- (2) Ambient temperature should be 50°F (10°C) to 90.5°F (32.5°C), with humidity from 20 to 80%RH.
- (3) This fax should not be used in a location where there is ammonia gas emission, high temperature and humidity (such as near water faucets, hot water heaters, humidifiers, etc.), locations near fire sources, and dusty locations.
- (4) Avoid exposing the equipment to direct sunlight. If necessary, instruct the user to use a curtain to screen sunlight.
- (5) Install in a well ventilated environment.

b) Check recording paper

- (1) Only recommended recording paper should be used.
- (2) Care should be taken with the storage of recording paper. Store the paper in environmental conditions as close those in which the machine is being operated. In particular, should the paper be subjected to high humidity, it will lose its rigidity and making it liable to jam.

5.1.2 Precautions for troubleshooting

- (1) Before starting any other troubleshooting, check that all connectors and printer cables are securely connected.
- (2) When effecting repairs with the outer cover open, and the power cord plugged into the socket, exercise caution so as not to receive an electrical shock from the power supply unit, or to short out the logic board.
- (3) When you have finished troubleshooting, be sure not to forget any connectors, or to leave any screws loosened.
- (4) When you have finished troubleshooting, be sure to carry out a communications test to ensure that everything is working properly.

5.2 Error Shown on the Display

5.2.1 User error message

"# ALREADY IN USE"

Cause: The box specified with confidential or polling communications is already in use.

Solution: Change the setting or select another box.

"AUTO REDIAL"

Cause: The other party's line was busy on the previous dialing attempt and the fax unit is dialing the number again.

Solution: To cancel redialing, press **Stop** button when direct dialing or press **Delete File**, select transaction number then press **Set** when memory sending.

"BUSY/NO SIGNAL" (#0005, #0018)

Cause: There was no response from the other fax within 35 seconds. (T1 timer over)

Solution:

- (1) Transmit again. Since there is a possibility that the other fax is not a G3 fax, check the other fax's communications mode.
- (2) When send documents long distance, press **Pause** button after dialing.
- (3) There is a possibility that the other party has turned off the fax unit.

"CHECK DOCUMENT" (#0001, #0011)

Cause: Document jam. This is displayed when the document sensor detects paper, but the document edge sensor cannot detect the leading edge of the document within 15 seconds from the start of the feed operation.

Solution:

- (1) Remove the document and try again.
- (2) If the document does not feed correctly, clean the rollers.
Refer to *this chapter, 3. CLEANING*.

"CHECK PAPER SIZE" (when Printer board I is installed)

Cause: Paper-size-matching error of the MP tray. Set different paper size in the fax menus and in the printer menus, or the **USE MP TRAY** menu is not turned off while using the MP tray for the printer function and loading paper of sizes other than letter, legal or A4.

Solution: Set the correct paper size in both of the fax and printer menus, or turn off **USE MP TRAY** in the fax menus.

"CHECK POLLING ID" (#0008, #0021)

Cause: Polling was impossible because the polling ID or your subaddress/password did not match.

Solution: Check the polling ID or subaddress/password with the other party and try polling again.

"CHECK PRINTER"

See Printer error codes (##322~##325)

"CHECK PRINTER COVER"

Cause: (1) Displayed when the printer cover sensor detects an open cover.
(2) Displayed when the toner cartridge is not installed.

Solution: (1) Close the printer cover.
(2) Install a toner cartridge.

"CHECK SUBADDR/PASSWD" (#0083, #0102)

Cause: Password/subaddress does not match.

Solution: Contact the other party and confirm that the subaddress/password that you are using are correct.

"COMMUNICATING PLEASE WAIT"

Cause: You tried to use direct sending while the fax was sending another document.

Solution: Wait until the transmission is finished, then try again.

"DATA ERROR PRESS SET KEY"

Cause: Check sum error. This is displayed when the SCNT board is replaced, when the SRAM is defective, or when the backup battery is replaced.

Solution: Press the **SET** button.

"DOCUMENT TOO LONG" (#0003)

Cause: Displayed when one page of the document was longer than 39.4 inches (1 meter) or transmission/copying took longer than the regulated time (32 minutes).

Solution: (1) Use a copy machine to copy the document onto several shorter pages, then transmit again.
(2) Reduce them on a copy machine if necessary. Then paste them on standard letter or A4-size sheets for scanning.

"ENTER DAC"

Cause: The department access code is not entered to send document.
Solution: Enter the department access code.

"HANG UP PHONE"

Cause: The handset was left off the hook after the completion of transmission or reception.
Solution: Put the handset back on the handset rest.

"MEMORY FULL" (#0037)

Cause: The image data storage memory area is full.
Solution: (1) Output the image data stored in memory.
(2) If tried to send a document with **"Ultra Fine"**, **"Super Fine"** or **"Text/Photo"**, try sending by direct sending, or set **"Fine"** or **"Text"** and send by memory sending.

"MEMORY FULL PLEASE WAIT"

Cause: The image data storage memory area is full.
Solution: Wait until the current document transmission has completed.

"NO ANSWER"

Cause: The other party did not answer.
Solution: (1) Start the procedure again from the beginning and try again.
(2) If the connection fails again, make sure the other party is using a G3-compatible fax machine.

"NO CONFID. TX" (#0033, #0034)

Cause: (1) The other fax machine may not have the confidential function.
(2) ITU-T subaddress/password does not match.
(3) It is possible that the other fax has no free memory.
Solution: Check the above items for the other fax.

"NO DOC. STORED"

Cause: Tried to check the contents of the memory but no documents are currently stored in the memory.
Solution: No need.

"NO ORIGINAL RELAY TX" (#0035, #0036)

Cause: (1) It is possible that the other fax has no relay function.
(2) ITU-T subaddress/password does not match.
(3) It is possible that the other fax has no free memory.
Solution: Check the above items for the other fax.

"NO RX PAPER" (#0012)

- Cause:** Declares that the other fax has no recording paper for DIS.
Solution: Contact the other party and have them load paper into their fax.

"NO TEL#" (#0022)

- Cause:** No one-touch speed dialing, coded speed dialing, or group dialing telephone number is registered.
Solution: Register the one-touch speed dialing, coded speed dialing, or group dialing telephone number.

"NOT AVAILABLE NOW"

- Cause:** You pressed an one-touch speed dialing, coded speed dialing, or group dialing, that is not registered for the feature you are trying to use.
Solution: Check the contents of the one-touch speed dialing, coded speed dialing, or group dialing registration, then try again.

"NOT FOUND, TRY AGAIN"

- Cause:** The box number you specified does not exist.
Solution: Try again with a different number.

"OUTPUT TRAY FULL "

- Cause:** The output tray is full of paper.
Solution: Pick up the printed pages on the tray.

"PASSWORD POLL REJECT"

- Cause:** You set up a polling box for polling sending with an ITU-T password, but the other party's fax unit does not support use of an ITU-T password for polling receiving.
Solution: Transmit without an ITU-T password.

"PASSWORD TX REJECT"

- Cause:** You attempted to send a document with an ITU-T password, but the other party's fax unit does not support use of an ITU-T password for receiving.
Solution: Transmit without an ITU-T password.

"PRT ALT. PAPER SIZE? YES=(*) NO=(#)"

- Cause:** The size of the available recording paper does not match the size of the document waiting to be printed.
Solution: If you do not mind printing on a different paper size, press * button. If you want to print the correct paper size, press **Stop** button and install the correct size paper. Then press **Start/Scan** button.

"REC. PAPER JAM" (#0009)

- Cause:** Recording paper jam
This is displayed when the pre-feed sensor or the fixing unit delivery sensors 1&2 detects a paper jam.
- Solution:** Recover paper jam.

"RECEIVED IN MAILBOX"

- Cause:** A confidential document has arrived in a mailbox of the fax unit, and the message will remain displayed until you print the document.
- Solution:** Output the document in the confidential mailbox.

"RECEIVED IN MEMORY"

- Cause:** (1) The fax unit has run out of recording paper.
(2) The toner supply of the toner cartridge is exhausted.
(3) The output tray is full of paper.
- Solution:** (1) Supply paper to the paper cassettes.
(2) Change the toner cartridge.
(3) Pick up the printed pages on the tray.

"RECEIVED IN MAM. BOX"

- Cause:** You have received a document in a memory box.
- Solution:** Print out the document in the memory box.

"REPLACE CARTRIDGE"

- Cause:** (1) The toner in the toner cartridge has run out. This is displayed when the toner sensor detects empty toner.
(2) Toner detection structure defects.
- Solution:** (1) Replace the toner cartridge.
(2) Check the ECNT board TB63 terminal connections.
(3) Replace the ECNT board.
(4) Replace the TWINS board.
(5) Replace the SCNT board.

"SELECTIVE POLL REJECT"

- Cause:** You have setup a polling box for polling sending with an ITU-T subaddress, but the other party's fax unit does not support use of an ITU-T subaddress for polling receiving.
- Solution:** Transmit without a subaddress.

"START AGAIN"

- Cause:** An error due to system malfunction or line breakdown.
- Solution:** Carry out the same operation again.

"STOP KEY PRESSED"

Cause: You have pressed the **Stop** button to cancel the current transaction.

Solution: No need.

"SUBADDRESS TX REJECTD"

Cause: You attempted to send a document with an ITU-T subaddress, but the other party's fax unit does not support receiving a document with an ITU-T subaddress.

Solution: Transmit without a subaddress.

"SUPPLY REC. PAPER" (#0009)

Cause: (1) Either recording paper run out or there is no recording paper cassette loaded. This is displayed when the cassette paper sensor detects no paper.

(2) The recording paper cassette is not loaded correctly. This is displayed when the cassette paper size sensor detects no cassette.

Solution: (1) Refill the recording paper in the cassette.

(2) Install the paper cassette correctly.

"USER ACCESS CODE"

Cause: This is displayed when the user access code is registered to send, copy or print reports.

Solution: Enter the user access code.

"USER ACCESS LOCK"

Cause: Sending or printing has been restricted.

Solution: Set the **TX SETTING** or **FAX'S PRINTER SET** of **2. RESPECTIVE CODES** in the user data **7. SYSTEM SETTINGS** to OFF.

5.2.2 Error codes

a) Service error code output

If Service Data #1 SSSW SW01 bit 0 is set to “1”, then service error codes are printed on the activity management reports, reception result reports, error transmission reports, and system dump lists when communication ends in an error. Also, the following is displayed on the display when an error occurs.

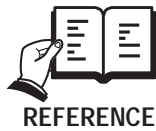

For samples of reports with the service error codes displayed, see *Chapter 2: 2.1.2 Service report output functions*.

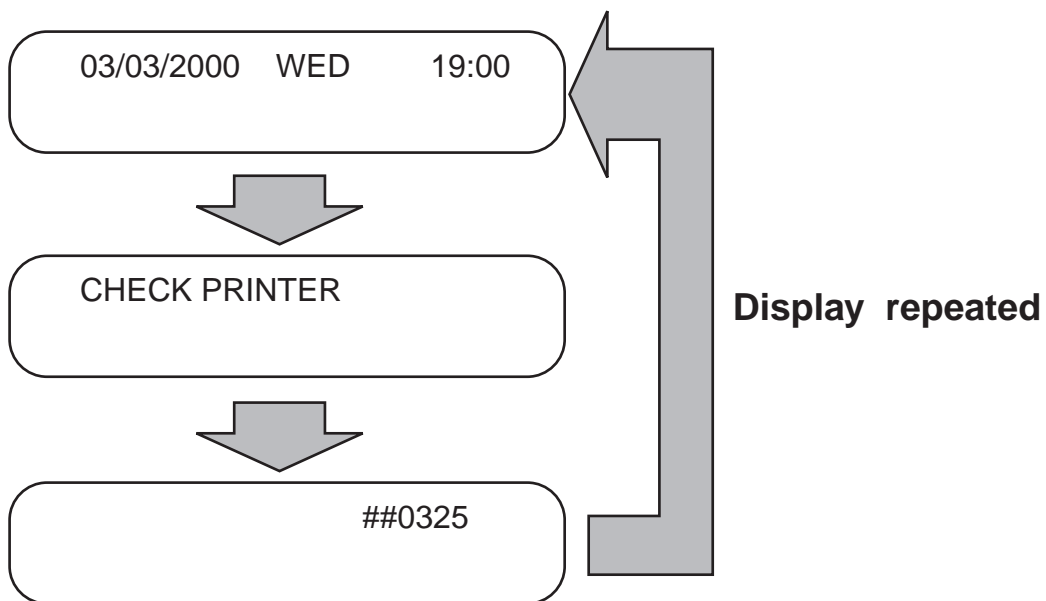

Figure 4-45 Service Error Code Display

b) Measure when an error code is output

Section c) shows the error codes displayed on this fax. However, they do not include the causes and measures that are described in a separate document titled *G3 Facsimile Error Code List (Rev. 1)*. See also this document.

The measures shown in the *G3 Facsimile Error Code List (Rev. 1)* and applicable to this fax machine are explained below.

- **Increase the transmission level**

Set service data #2MENU Parameter No.07 to -8 (dBm).

- **Decrease the transmission level**

Set service data #2MENU Parameter No.07 to -15 (dBm).

•Echo measures

Change the following bit switches of service data #1SSSW SW03.

- Bit 4 → 1: Ignore the first DIS signal sent by the other fax machine.
0: Not to ignore the first DIS signal sent by the other fax machine.
- Bit 5 → 1: Transmit a tonal signal (1850 or 1650 Hz) when the other fax machine sends a DIS signal.
0: Not to transmit a tonal signal when the other fax machine sends a DIS signal.
- Bit 6 → 1: Transmit a 1650Hz tonal signal when bit 5 is 1.
0: Transmit a 1850Hz tonal signal when bit 5 is 1.
- Bit 7 → 1: Transmit a tonal signal before sending a CED signal.
0: Not to transmit a tonal signal before sending a CED signal.

•EPT

Change service data #1SSSW SW03 bit 1.

- Bit 1 → 1: Transmit an echo protect tone.
0: Not to transmit an echo protect tone.

•Adjust NL equalizer.

Set service data #2MENU Parameter No.05 to “ON”.

•Reduce the transmission start speed.

Reduce the transmission speed by changing user data “SYSTEM SETTINGS” “TX START SPEED”.

•Loosen the TCF judgment standard.

Not available for this fax.

•Loosen the RTN transmission conditions.

Change service data #3NUMERIC Param. Parameter No.02 to 04.

- No.02 Percentage of errors in all lines : Set close to 99%.
- No.03 Number of lines of burst condition : Set close to 99 lines.
- No.04 Number of burst line groups : Set close to 99 groups.

•Increase the no-sound time after CFR reception.

Change service data #1SSSW SW04 bit 4 to “1”.

- Bit 4 → 1: Time when the low-speed signal is ignored after sending a CFR signal: 1500 ms
- 0: Time when the low-speed signal is ignored after sending a CFR signal: 700 ms

c) Error code list

The error codes used for this fax are as follows.

Codes listed as “New” in the list below indicate new error codes, or codes whose measures differ from those listed in the separate document *G3 Facsimile Error Code List (Rev.1)*.

For recovery methods for error codes indicated as “New”, see the item *d) Recovery methods for codes indicated as “New” in this chapter, 5.2.2 Error codes*.

For items other than “New”, see the separate document *G3 Facsimile Error Code List (Rev.1)*.

c-1) User error codes

	No.	Tx or Rx	Definition
New	#0001	[TX]	Paper jam
New	#0003	[TX/RX]	Copy page, transmission time over
New	#0005	[TX/RX]	Initial ID (T0/T1) time over
	#0008	[TX]	Polling password error
New	#0009	[RX]	Recording paper jam or out of paper
	#0011	[RX]	Polling error
	#0012	[TX]	Other party out of paper
	#0018	[TX]	Automatic dialing error
New	#0021	[RX]	DCN during polling reception
	#0022	[TX]	Call failure
New	#0025	[TX/RX]	Automatic dialing setting error
	#0033	[TX]	Confidential transmission failure
	#0034	[TX]	Failure to transmit to other party’s confidential mailbox
	#0035	[TX]	No original relay transmission
	#0036	[TX]	No original relay transmission
	#0037	[RX]	Image memory full
New	#0039	[TX]	Closed network Tx failure
New	#0056	[RX]	Faulty recording paper feeding
New	#0057	[RX]	Faulty recording paper feeding
New	#0058	[RX]	Faulty recording paper feeding
New	#0059	[TX]	The number you dial and connected number (CSI) does not match
	#0080	[TX]	Other party does not have ITU-T recommended sub-address reception function
New	#0081	[TX]	Other party does not have ITU-T recommended password reception function
New	#0082	[RX]	Other party does not have ITU-T recommended selective polling transmission function
New	#0083	[RX]	DCN received during polling reception
New	#0084	[RX]	In polling reception, other party does not have ITU-T recommended password reception
New	#0099	[TX/RX]	Pressed stop button during communication
New	#0102	[TX]	In transmission, DCN received in response to password/sub-address

No.	Tx or Rx	Definition
#0995	[TX/RX]	The image data stored in memory have been cleared

c-2) Service error codes

• G3 mode error codes

No.	Tx or Rx	Definition
##0100	[TX]	Excessive repeat protocol during transmission
##0101	[TX/RX]	Modem speed different from other party
##0102	[TX]	Fall back failure during transmission
##0103	[RX]	Fail to detect EOL for 5 seconds (15 seconds for CBT) during reception
##0104	[TX]	RTN or PIN received during transmission
##0106	[RX]	Fail to receive protocol for 6 seconds when waiting for protocol during reception
##0107	[RX]	Fall back failure on transmission side during reception
##0109	[TX]	Receive signals other than DIS, DTC, FTT, CFR or CRP after DCS Tx and exceed the number of protocol re-transmissions during transmission
##0111	[TX/RX]	Memory error
##0114	[RX]	RTN transmission during reception
##0116	[TX/RX]	Detect loop current disconnection during communication
##0200	[RX]	Fail to detect picture reception carrier for 5 seconds during reception
##0201	[TX/RX]	DCN reception other than normal binary protocol
##0223	[TX]	Line disconnected during communication
##0224	[TX/RX]	Abnormal protocol during G3 communication
##0229	[RX]	Recording unit locked for 1 minute
##0232	[TX]	ENCODE control unit malfunction
##0237	[RX]	DECODE control unit malfunction
##0238	[RX]	PRINT control unit malfunction
##0261	[TX/RX]	System error between MODEM and SCNT
##0280	[TX]	Excessive repeat protocol command during transmission
##0281	[TX]	Excessive repeat protocol command during transmission
##0282	[TX]	Excessive repeat protocol during transmission
##0283	[TX]	Excessive repeat protocol during transmission
##0284	[TX]	DCN reception after TCF transmission
##0285	[TX]	DCN reception after EOP transmission
##0286	[TX]	DCN reception after EOM transmission
##0287	[TX]	DCN reception after MPS transmission
##0288	[TX]	Receive signals other than PIN, PIP, MCF, RTP or RTN after EOP transmission
##0289	[TX]	Receive signals other than PIN, PIP, MCF, RTP or RTN after EOM transmission

No.	Tx or Rx	Definition
##0290	[TX]	Receive signals other than PIN, PIP, MCF, RTP or RTN after MPS transmission

• **Printer error codes**

No.	Tx or Rx	Definition
New ##0322	[RX]	Printer (LBP) fixing unit trouble
New ##0323	[RX]	Printer (LBP) BD (Beam Detect) trouble
New ##0324	[RX]	Printer (LBP) scanner trouble
New ##0325	[RX]	Printer (LBP) main motor trouble

• **V.8/V.34 protocol error codes**

No.	Tx or Rx	Definition
New ##0670	[TX]	At V.8 late start, the called party declares the V.8 protocol in DIS signal and this unit transmits a CI signal, but the protocol does not progress and a T1 time-out occurs.
New ##0671	[RX]	At V.8 termination, the protocol did not advance to phase 2 and a T1 time-out occurs after the caller CM signal was detected.
New ##0672	[TX]	The protocol did not move from phase 2 to phase 3 and a T1 time-out occurred during V.34 transmission.
New ##0673	[RX]	The protocol did not move from phase 2 to phase 3 and a T1 time-out occurred during V.34 reception.
New ##0674	[TX]	The protocol did not move from phase 3 to phase 4 and a T1 time-out occurred during V.34 transmission.
New ##0675	[RX]	The protocol did not move from phase 3 to phase 4 and a T1 time-out occurred during V.34 reception.

• **ECM mode error codes**

	No.	Tx or Rx	Definition
	##0750	[TX]	Exceed repeat protocol due to failure to receive significant signals after transmitting PPS-NULL during ECM transmission
	##0752	[TX]	Receive DCN after PPS-NULL transmission during ECM transmission
New	##0753	[TX]	Exceed protocol retransmission limit or T5 time (60 seconds) after PPS-NULL transmission during ECM transmission
	##0754	[TX]	Exceed retransmit protocol after PPS-NULL transmission during ECM transmission
	##0755	[TX]	Exceed protocol retransmission limit due to failure to receive significant signals after PPS-MPS transmission during ECM transmission during ECM transmission
	##0757	[TX]	Receive DCN after PPS-MPS Transmission during ECM transmission
New	##0758	[TX]	Exceed protocol retransmission limit or T5 time (60 seconds) after PPS-MPS transmission during ECM transmission
	##0759	[TX]	Exceed retransmit protocol after PPS-MPS transmission during ECM transmission
	##0760	[TX]	Exceed protocol retransmission limit due to failure to receive significant signals after PPS-EOM transmission during ECM transmission
	##0762	[TX]	Receive DCN after PPS-EOM transmission during ECM transmission
New	##0763	[TX]	Exceed protocol retransmission limit or T5 time (60 seconds) after PPS-MPS transmission during ECM transmission
	##0764	[TX]	Exceed retransmit protocol after PPS-EOM transmission during ECM transmission
	##0765	[TX]	Exceed protocol retransmission limit due to failure to receive significant signals after PPS-EOP transmission during ECM transmission
	##0767	[TX]	Receive DCN after PPS-EOP transmission during ECM transmission
New	##0768	[TX]	Exceed protocol retransmission limit or T5 time (60 seconds) after PPS-EOP transmission during ECM transmission
	##0769	[TX]	Exceed retransmit protocol after PPS-EOP transmission during ECM transmission

No.	Tx or Rx	Definition
##0770	[TX]	Exceed repeat protocol limit due to failure to receive significant signals after transmitting EOR-NULL during ECM transmission
##0772	[TX]	Receive DCN after EOR-NULL transmission during ECM transmission
New ##0773	[TX]	Exceed protocol retransmission limit or T5 time (60 seconds) after EOR-NULL transmission during ECM transmission
##0774	[TX]	Receive ERR after EOR-NULL transmission during ECM transmission
##0775	[TX]	Exceed protocol retransmission limit due to failure to receive significant signals after EOR-MPS transmission during ECM transmission
##0777	[TX]	Receive DCN after EOR-MPS transmission during ECM transmission
New ##0778	[TX]	Exceed protocol retransmission limit or T5 time (60 seconds) after EOR-MPS transmission during ECM transmission
##0779	[TX]	Receive ERR after EOR-MPS transmission during ECM transmission
##0780	[TX]	Exceed protocol retransmission limit due to failure to receive significant signals after EOR-EOM transmission during ECM transmission
##0782	[TX]	Receive DCN after EOR-EOM transmission during ECM transmission
New ##0783	[TX]	Exceed protocol retransmission limit or T5 time (60 seconds) after EOR-EOM transmission during ECM transmission
##0784	[TX]	Receive ERR after EOR-EOM transmission during ECM transmission
##0785	[TX]	Exceed protocol retransmission limit due to failure to receive significant signals after EOR-EOP transmission during ECM transmission
##0787	[TX]	Receive DCN after EOR-EOP transmission during ECM transmission
New ##0788	[TX]	Exceed protocol retransmission limit or T5 time (60 seconds) after EOR-EOP transmission during ECM transmission
##0789	[TX]	Receive ERR after EOR-EOP transmission during ECM transmission
##0790	[RX]	Transmit ERR after EOR-Q reception during ECM reception
##0791	[TX/RX]	Receive non-significant signals during ECM mode procedures

No.	Tx or Rx	Definition
##0792	[RX]	Fail to detect PPS-NULL between partial pages during ECM reception
##0793	[RX]	Time over due to failure to receive valid frame during high speed signal reception upon ECM reception
##0794	[TX]	Receive all 0 PPR during ECM transmission
##0795	[TX/RX]	Trouble in the decoding processing during communication
##0799	[TX]	System error

d) Recovery methods for codes indicated as “New”

d-1) User error codes

#0001 [TX] Paper jam

Cause: The document jammed in the fax machine.

Solution: Remove the document and transmit/copy again.

Cause: The document width size or thickness does not meet the standards.

Solution: Use a copy machine to copy the document to LTR or other standard size paper, then transmit that copy.

Cause: Internal structure defect

Solution: (1) Check if the document sensor (DS) and document edge sensor (DES) are operating correctly using the methods given in *Chapter 2: 2.4.7 Faculty tests*, Test Mode [6] Faculty Test, [3] Sensor Tests.

(2) Check the SENSOR board (J1) and SCNT board (J12) connections.

(3) Check the document edge sensor (DES) and SCNT board (J14) connections.

(4) Make a copy, and make sure that the document read motor is operating correctly.

(5) Check the document read motor and SCNT board (J4) connections.

(6) Replace the SENSOR board.

(7) Replace the document edge sensor (DES).

(8) Replace the document read motor.

(9) Replace the SCNT board.

#0003 [TX/RX] Copy page transmission time over

Cause: One page of the document was longer than 39.4 inches (1 meter) or transmission/copying took longer than the regulated time (32 minutes).

Solution: (1) Use a copy machine to copy the document onto several shorter page, then transmit/copy.

(2) Raise the page timer value with Service Data #1 SSSW SW12.

Cause: Reception took longer than the regulated time (32 minutes).

Solution: (1) Have the other party split the document over multiple pages and receive it that way.

(2) Contact the other party and check the cause.

(3) Raise the page timer value with Service Data #1 SSSW SW12.

Cause: Internal structure defect

- Solution:**
- (1) Check if the document edge sensor (DES) is operating correctly using the methods given in *Chapter 2: 2.4.7 Faculty tests*, Test Mode [6] Faculty Test, [3] Sensor Tests.
 - (2) Check the document edge sensor (DES) and SCNT board (J14) connections.
 - (3) Make a copy, and make sure that the document read motor is operating correctly.
 - (4) Check the document feed motor and SCNT board (J4) connections.
 - (5) Replace the document edge sensor (DES).
 - (6) Replace the document read motor.
 - (7) Replace the SCNT board.

#0005 [TX/RX] Initial identification time (T0/T1) over

Cause: Tone/pulse parameter set incorrectly.

Solution: Set the user data “**TEL LINE TYPE**” tone/pulse parameter correctly.

Cause: The time until connection with the other fax is too long.

- Solution:**
- (1) When registering for auto dialing, add a long pause to delay the start of the timer.
 - (2) Lengthen the T0 timer with Service Data #3 Numeric param. 10 so that the timer does not time out.

Cause: The other fax does not answer.

Solution: Contact the other party and have them check for the cause.

Cause: A significant signal has not been received after starting transmitting the DIS signal.

Solution: Lengthen the T1 timer (Rx) with Service Data #3 Numeric param. 11 so that the time-out error does not occur.

Cause: The communications mode (G2, G3, etc.) of the other fax does not match that of this fax.

Solution: The communications mode is a part of specification for the fax, so there is no countermeasure.

Cause: (1) The other fax malfunctioned during transmission due to echoes.

(2) Malfunction due to echoes during reception

Solution: Implement echo countermeasures, given in this manual in *G3 Facsimile Service Data Handbook (Rev. 0) explanation of #1 SSSW SW03*.

#0009 [RX] Recording paper jam or out of paper

Cause: The recording paper jammed.

Solution: Clear the recording paper jam.

Cause: There is no recording paper.

Solution: Load recording paper.

Cause: Internal structure defect

Solution: (1) Check if the cassette recording paper sensors, cassette recording paper size sensors, multi-purpose tray paper sensor, recording paper eject sensor are operating correctly using the methods given in *Chapter 2: 2.4.7 Faculty tests*, Test Mode [6] Faculty Test, [3] Sensor Tests.

(2) If the malfunction is not in multi-purpose tray feeding, goes to step (10);

(3) Check the multi-purpose tray paper sensor (PS105), the sensor cable and the ECNT board (J58) connections.

(4) Check the main motor, main motor connector (J301) and the ECNT board (J52) connections.

(5) Replace the multi-purpose tray paper sensor.

(6) Replace the main motor.

(7) Replace the ECNT board.

(8) Replace the TWINS board.

(9) Replace the SCNT board.

(10) If the malfunction is not in cassette feeding, goes to step (21);

(11) Check the cassette recording paper sensors (PS101, PS801), the sensor cables and the paper size detection boards (J602, J803) connections.

(12) Check the paper size detection board 2 (J801), paper feeder connector (J811, J812, J104, J106) and paper size detection board 1 (J601) connections.

(13) Check the paper size detection board 1 (J603) and the ECNT board (J72) connections.

(14) Check the main motor, main motor connector (J301) and the ECNT board (J52) connections.

(15) Replace the cassette recording paper sensor.

(16) Replace the paper size detection boards. (Cassette recording paper size sensor defect)

(17) Replace the main motor.

(18) Replace the ECNT board.

(19) Replace the TWINS board.

(20) Replace the SCNT board.

- (21) Check the recording paper eject sensor 2, the cable and the fixing unit (J131) connections.
- (22) Replace the recording paper eject sensor 2.
- (23) Replace the ECNT board.
- (24) Replace the ECNT board. (Recording paper eject sensor 1 defect)

#0021 [RX] DCN received during polling reception

- Cause:** No subaddress/password set in other machine.
Solution: Contact the other party and check subaddress/password of the other party.

#0025 [TX/RX] Automatic dialing setting error

- Cause:** An attempt was made to auto dial with confidential and relay set in auto dialing.
Solution: Set confidential and relay correctly for auto dialing.

#0039 [TX] Closed network transmission not possible

- Cause:** The closed network transmission switch is switched off.
Solution: Set Service Data #1 SSSW SW07 bit 7 to "1" to switch on closed network transmission.
- Cause:** The other fax's closed network transmission switch is switched off.
Solution: Have the other party switch on the closed network reception switch on their fax.
- Cause:** The closed network ID does not match the other fax's.
Solution: Use Service Data #1 SSSW SW08 to set the same closed network ID for your fax and for the other fax.

#0056 [RX] Faulty recording paper feeding

- Cause:** The recording paper jammed when both the pre-feed sensor and the recording paper eject sensor were OFF.
Solution: Recover recording paper jam.

#0057 [RX] Faulty recording paper feeding

- Cause:** The recording paper jammed when the pre-feed sensor was ON and the recording paper eject sensor was OFF.
Solution: Recover recording paper jam.

#0058 [RX] Faulty recording paper feeding

- Cause:** The recording paper remains fixed when the recording paper eject sensor is ON.
Solution: Recover recording paper jam.

#0059 [TX] The number you dial and connected number (CSI) does not match

Cause: “USER TEL” on the reception side not programmed, or wrongly programmed.

Solution: (1) Contact reception side and check whether “USER TEL” has been properly programmed.
(2) Check that the designated other party is connected, and transmit manually.

Cause: Faulty operation by exchange. Designated other party is not connected.

Solution: Inspect exchange.

#0080 [TX] Other party does not have ITU-T recommended subaddress reception

Cause: The other party’s DIS bit 49 is 0.

Solution: Contact the other party and confirm whether or not their fax supports subaddress receiving. Try sending again without a subaddress.

#0081 [TX] Other party does not have ITU-T recommended password reception

Cause: The other party’s DIS bit 50 is 0.

Solution: Contact the other party and confirm whether or not their fax supports ITU-T password receiving. Try sending again without a password.

#0082 [RX] Other party does not have ITU-T recommended selective polling transmission function

Cause: The other party’s DIS bit 47 is 0.

Solution: Contact the other party and confirm whether or not their fax can accept a polling request with a subaddress. Try again without a subaddress.

#0083 [RX] DCN received during polling reception

Cause: Subaddress/password does not match.

Solution: Contact the other party and conform that the subaddress/password that you are using are correct.

#0084 [RX] In polling reception, other party does not have ITU-T recommended password reception

Cause: The other party’s DIS bit 50 is 0.

Solution: Contact the other party and confirm whether or not their fax supports receiving a polling request with an ITU-T password. Try again without a password.

#0099 [TX/RX] Pressed stop button during communication

Cause: The Stop button was pressed during communication.

Solution: Try transmit or receive again.

#0102 [TX] In transmission, DCN received in response to password/sub-address

Cause: Password/subaddress does not match.

Solution: Contact the other party and have them set a password/subaddress.

Cause: Other party's memory is full.

Solution: Contact the other party and have them make sufficient memory available.

d-2) Service error codes

• **Printer error codes**

##0322 [RX] Fixing heater temperature abnormality

Cause: Your fax is connected to a UPS
(Uninterruptable Power Supply).

Solution: Remove the UPS.

Cause: Internal unit defect

Solution: (1) Check fixing heater (J133, J134), the cables and the ECNT board (J31) connections.
(2) Remove the fixing unit, and check the resistance between fixing unit (J132-1:THEM) and (J132-2:GND), which should be 300 to 500 ohm.
(3) Remove the fixing unit, and check the continuity between fixing unit (J142:HOT) and (J143:NEUTRAL), which should be continued.
(4) Replace the fixing film ass'y.
(5) Replace the ECNT board.

##0323 [RX] Laser/scanner unit BD signal output function abnormality

Cause: Internal unit defect

Solution: (1) Check the BD board (J551) and the cable connections.
(2) Check the laser/scanner unit and ECNT board (J53) connections.
(3) Replace the laser/scanner unit.
(4) Replace the ECNT board.

##0324 [RX] Printer section scanner motor rotation rate abnormality

Cause: Internal unit defect

Solution: (1) Check the scanner motor (J401) and the cable connections.
(2) Check the laser/scanner unit and ECNT board (J53) connections.
(3) Replace the laser/scanner unit
(4) Replace the ECNT board.

##0325 [RX] Main motor rotation rate abnormality

Cause: Internal unit defect

Solution: (1) Check the main motor, main motor connector (J301) and ECNT board (J52) connections.
(2) Replace the main motor.
(3) Replace the ECNT board.

- V.8/V.34 protocol error codes

##0670 [TX] At V.8 late start, the called party declares the V.8 protocol in DIS signal and this unit transmits a CI signal, but the protocol does not progress and a T1 time-out occurs.

Cause: The other party disconnected the line while the CI signal was being transmitted, or ANSam/DIS from the called party was not able to be detected.

Solution: Increase #2 MENU No.07 transmission level within a range of -8~-15 (dBm) or set #1 SSSW SW-28 bit 0 to "1" to inhibit the V.8/V.34 protocol on calling.

##0671 [RX] At V.8 termination, the protocol did not advance to phase 2 and a T1 time-out occurs after the caller CM signal was detected.

Cause: The caller disconnected the line or the signal from the caller was not able to be detected.

Solution: Increase #2 MENU No.07 transmission level within a range of -8~-15 (dBm) or set #1 SSSW SW-28 bit 1 to "1" to inhibit the V.8/V.34 protocol for the called party.

##0672 [TX] The protocol did not move from phase 2 to phase 3 and a T1 time-out occurred during V.34 transmission.

Cause: The called party disconnected the line during phase 2 or the signal from the called party was not able to be detected.

Solution: Increase #2 MENU No.07 transmission level within a range of -8~-15 (dBm) or set #1 SSSW SW-28 bit 0 to "1" to inhibit the V.8/V.34 protocol on calling.

##0673 [RX] The protocol did not move from phase 2 to phase 3 and a T1 time-out occurred during V.34 reception.

Cause: The transmitter disconnected the line during phase 2 or the signal from the transmitter was not able to be detected.

Solution: Increase #2 MENU No.07 transmission level within a range of -8~-15 (dBm) or set #1 SSSW SW-28 bit 1 to "1" to inhibit the V.8/V.34 protocol on termination.

##0674 [TX] The protocol did not move from phase 3 to phase 4 and a T1 time-out occurred during V.34 transmission.

Cause: The called party disconnected the line during phase 3 or the signal from the called party was not able to be detected.

Solution: Increase #2 MENU No.07 transmission level within a range of -8~-15 (dBm) or set #1 SSSW SW-28 bit 0 to "1" to inhibit the V.8/V.34 protocol on calling.

##0675 [RX] The protocol did not move from phase 3 to phase 4 and a T1 time-out occurred during V.34 reception.

Cause: The transmitter disconnected the line during phase 3 or the signal from the transmitter was not able to be detected.

Solution: Increase #2 MENU No.07 transmission level within a range of -8~-15 (dBm) or set #1 SSSW SW-28 bit 1 to "1" to inhibit the V.8/V.34 protocol on termination.

• ECM mode error codes

##0753 [TX] Exceed protocol retransmission limit or T5 time (60 seconds) after PPS-NUL transmission during ECM transmission

Cause: The other fax's page buffer is full or is being used, so PPS-NUL was transmitted, then RNR was received and after RR transmission, no significant signals could be received.

Solution: (1) In the user data "TX SETTINGS", set "ECM TX" to "OFF".
(2) Set user data "TX START SPEED" in "SYSTEM SETTINGS" to lower speed.

##0758 [TX] Exceed protocol retransmission limit or T5 time (60 seconds) after PPS-MPS transmission during ECM transmission

Cause: The other fax's page buffer is full or is being used, so PPS-MPS was transmitted, then RNR was received and after RR transmission, no significant signals could be received.

Solution: (1) In the user data "TX SETTINGS", set "ECM TX" to "OFF".
(2) Set user data "TX START SPEED" in "SYSTEM SETTINGS" to lower speed.

##0763 [TX] Exceed protocol retransmission limit or T5 time (60 seconds) after PPS-MPS transmission during ECM transmission

Cause: The other fax's page buffer is full or is being used, so PPS-MPS was transmitted, then RNR was received and after RR transmission, no significant signals could be received.

Solution: (1) In the user data "TX SETTINGS", set "ECM TX" to "OFF".
(2) Set user data "TX START SPEED" in "SYSTEM SETTINGS" to lower speed.

##0768 [TX] Exceed protocol retransmission limit or T5 time (60 seconds) after PPS-EOP transmission during ECM transmission

Cause: The other fax's page buffer is full or is being used, so PPS-EOP was transmitted, then RNR was received and after RR transmission, no significant signals could be received.

Solution: (1) In the user data "TX SETTINGS", set "ECM TX" to "OFF".
(2) Set user data "TX START SPEED" in "SYSTEM SETTINGS" to lower speed.

##0773 [TX] Exceed protocol retransmission limit or T5 time (60 seconds) after EOR-NULL transmission during ECM transmission

Cause: The other fax's page buffer is full or is being used, so EOR-NULL was transmitted, then RNR was received and after RR transmission, no significant signals could be received.

Solution: (1) In the user data "TX SETTINGS", set "ECM TX" to "OFF".
(2) Set user data "TX START SPEED" in "SYSTEM SETTINGS" to lower speed.

##0778 [TX] Exceed protocol retransmission limit or T5 time (60 seconds) after EOR-MPS transmission during ECM transmission

Cause: The other fax's page buffer is full or is being used, so EOR-MPS was transmitted, then RNR was received and after RR transmission, no significant signals could be received.

Solution: (1) In the user data "TX SETTINGS", set "ECM TX" to "OFF".
(2) Set user data "TX START SPEED" in "SYSTEM SETTINGS" to lower speed.

##0783 [TX] Exceed protocol retransmission limit or T5 time (60 seconds) after EOR-EOM transmission during ECM transmission

Cause: The other fax's page buffer is full or is being used, so EOR-EOM was transmitted, then RNR was received and after RR transmission, no significant signals could be received.

Solution: (1) In the user data "TX SETTINGS", set "ECM TX" to "OFF".
(2) Set user data "TX START SPEED" in "SYSTEM SETTINGS" to lower speed.

##0788 [TX] Exceed protocol retransmission limit or T5 time (60 seconds) after EOR-EOP transmission during ECM transmission

Cause: The other fax's page buffer is full or is being used, so EOR-EOP was transmitted, then RNR was received and after RR transmission, no significant signals could be received.

Solution: (1) In the user data "TX SETTINGS", set "ECM TX" to "OFF".
(2) Set user data "TX START SPEED" in "SYSTEM SETTINGS" to lower speed.

5.3 Errors not Shown on the Display

a) No power

- Solution:**
- (1) Plug in the power cord.
 - (2) Check the fuse in the power supply unit. If the fuse (F1, F2) blows, replace the fuse.
 - (3) Check the power supply and ECNT board (J101) connections.
 - (4) Replace the power supply unit.
 - (5) Replace the ECNT board.

b) No display

- Solution:**
- (1) Remove and reinstall the power cord.
 - (2) Check the SCNT board (J5) and OPCNT board (J100) connections.
 - (3) Replace the OPCNT board.
 - (4) Replace the SCNT board.

c) Characters are distorted

- Solution:**
- (1) Check the SCNT board (J5) and OPCNT board (J100) connections.
 - (2) Replace the OPCNT board.
 - (3) Replace the SCNT board.

d) Keys do not function

- Solution:**
- (1) Check the SCNT board (J5) and OPCNT board (J100) connections.
 - (2) Replace the OPCNT board.
 - (3) Replace the SCNT board.

d) Document feed error

The document is not fed

- Solution:**
- (1) Use the *Chapter 2: 2.4.7 Faculty Test*, Test Mode [6] Faculty Test [3] Sensor Test to check whether the document sensor is working normally.
 - (2) Check the SENSOR board (J1) and SCNT board (J12) connections.
 - (3) Replace the SENSOR board.
 - (4) Replace the SCNT board.

Document read motor does not run at all or dose not run normally

- Solution:**
- (1) Make a copy, and make sure that the document read motor is operating correctly.
 - (2) Check the SCNT board (J4) and document read motor connections.
 - (3) Replace the document read motor.
 - (4) Replace the SCNT board.

The document skews

- Solution:**
- (1) Check whether the document guide width is set correctly for the document to be loaded.
 - (2) Check whether paper whose thickness is lower or higher than the prescribed value is used.
 - (3) Check whether the document stopper is initialized correctly.
 - (4) Clean the separation roller (upper), the separation roller (lower), the document feed roller and eject roller.

Two or more documents are fed at the same time

- Solution:**
- (1) Check whether more documents than the maximum number of documents are set.
 - (2) Check whether paper whose thickness is lower or higher than the prescribed value is used.
 - (3) Clean the separation roller (upper), the separation roller (lower).
 - (4) Check whether the document stopper is initialized correctly.
 - (5) Replace the separation rollers (upper and lower).

e) Scanning error

See *Chapter 2: 3.4.4 Print test* and perform test print to confirm that there is no printing error.

Copy not printed

- Solution:**
- (1) Check the contact sensor and SCNT board (J3) connections.
 - (2) Replace the contact sensor.
 - (3) Replace the SCNT board.

Vertical white line/band in images

- Solution:**
- (1) Clean the white sheet of the middle reader frame unit.
 - (2) Clean the scanning glass.
 - (3) Check the contact sensor and SCNT board (J3) connections.
 - (4) Replace the contact sensor unit.

Vertical black band in images

- Solution:**
- (1) Clean the white sheet of the middle reader frame unit.
 - (2) Clean the scanning glass.
 - (3) Set SSSW #1 SW06 Bits 0 and 1 to "1", as explained in the separate document *G3 Facsimile Service Data Handbook (Rev. 0)*.
 - (4) Check the contact sensor and SCNT board (J3) connections.
 - (5) Replace the contact sensor.

f) No sound from the speaker

- Solution:**
- (1) Check the speaker unit and SCNT board (J10) connections.
 - (2) Replace the speaker unit.
 - (3) Replace the SCNT board.

g) Print defects

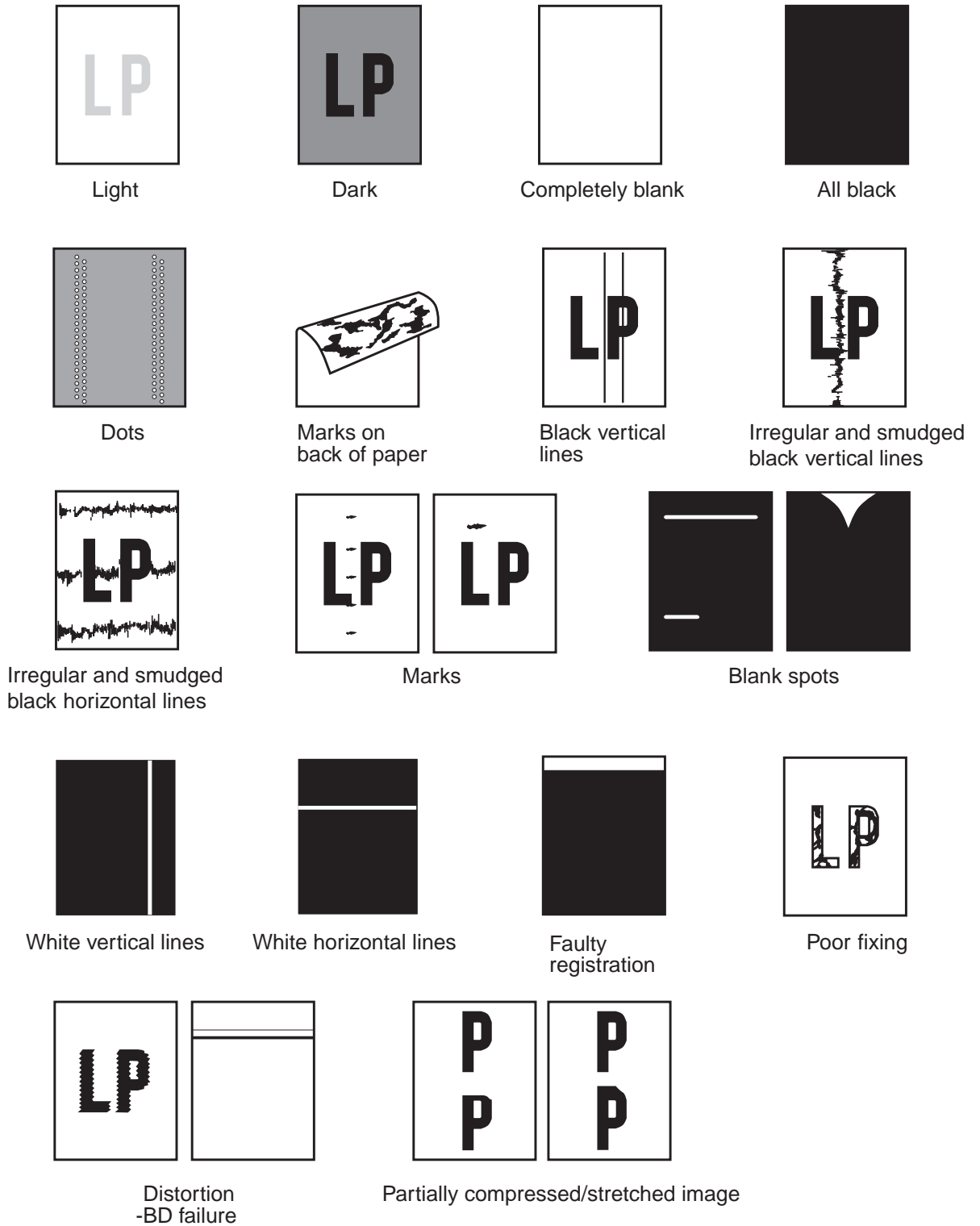

Figure 4-46 Faulty Print Samples

Light

- Solution:**
- (1) In user data, set “**SELECT DENSITY**” of “**FAX’S PRINTER SET**” to “**DK**”.
 - (2) Replace the toner cartridge.
 - (3) During printing, open the printer cover, remove the toner cartridge, open the toner cartridge drum protective shutter by hand, and check that the toner image on the photosensitive drum is transferred to the recording paper. If it is transferred and the toner image on the drum surface is light, go to (4). If the toner image on the drum is faint, go to (7).
Do not open the toner cartridge drum protective shutter for more than 10 seconds.
 - (4) Clean the high-voltage terminal, the toner cartridge contact and the transfer charging roller shaft contact.
 - (5) Replace the transfer charging roller.
 - (6) Replace the ECNT board.
 - (7) Replace the laser/scanner unit.
 - (8) Replace the ECNT board.

Dark

- Solution:**
- (1) In user data, set “**SELECT DENSITY**” of “**FAX’S PRINTER SET**” to “**LT**”.
 - (2) Clean the drum ground contact and the toner cartridge contact.
 - (3) Clean the high-voltage terminal and the toner cartridge contact.
 - (4) Replace the laser/scanner unit.
 - (5) Replace the ECNT board.

Completely blank

- Solution:**
- (1) Check if the toner cartridge drum protective shutter is damaged.
 - (2) Replace the toner cartridge.
 - (3) Clean the high-voltage terminal and the toner cartridge contact.
 - (4) Check if the laser shutter opens when you press the laser shutter lever.
 - (5) Replace the laser shutter lever or the laser shutter.
 - (6) Replace the ECNT board.

All black

- Solution:**
- (1) Clean the high-voltage terminal and the toner cartridge contact.
 - (2) Replace the toner cartridge.
 - (3) Replace the ECNT board.

Dots

- Solution:**
- (1) Clean the static charge eliminator with brush.
 - (2) Clean the transfer charging roller.
 - (3) Clean the transfer charging roller shaft contact.
 - (4) Check the contact between the static charge eliminator and the ECNT board.
 - (5) Check the contact between the transfer charging roller shaft and the ECNT board.
 - (6) Replace the transfer charging roller.
 - (7) Replace the ECNT board.

Marks on back of paper

- Solution:**
- (1) Copy a few white paper documents.
 - (2) If the marks is at intervals of approx. 2.97" (75 mm), clean the cassette feed roller.
 - (3) If the marks is at intervals of approx. 1.97" (50 mm), clean the feed roller and the pre-transfer roller.
 - (4) If the marks is at intervals of approx. 1.85" (47 mm), clean the transfer charging roller.
 - (5) If the marks is at intervals of approx. 2.48" (63 mm), clean the fixing pressure roller.
 - (6) Clean the paper feed belt.
 - (7) Clean the paper feed guide.
 - (8) Clean the fixing entrance guide.
 - (9) Replace the cassette feed roller.
 - (10) Replace the feed roller.
 - (11) Replace the pre-transfer roller.
 - (12) Replace the transfer charging roller.
 - (13) Replace the fixing pressure roller.

Black vertical lines

- Solution:**
- (1) Clean the mirror.
 - (2) During printing, open the printer cover, remove the toner cartridge drum protective shutter by hand, and check if there are vertical black lines on the photosensitive drum.
 - (3) If there are vertical black lines on the photosensitive drum, replace the toner cartridge.
 - (4) If there are not vertical black lines on the photosensitive drum, clean the fixing entrance guide.
 - (5) Check if the scars on the fixing film unit.
 - (6) Replace the fixing film unit.

Irregular and smudged black vertical lines

- Solution:**
- (1) During printing, open the printer cover, remove the toner cartridge drum protective shutter by hand, and check if there are vertical black lines on the photosensitive drum.
 - (2) If there are vertical black lines on the photosensitive drum, replace the toner cartridge.
 - (3) If there are not vertical black lines on the photosensitive drum, clean the fixing entrance guide.
 - (4) Check if the scars on the fixing film unit.
 - (5) Replace the fixing film unit.

Irregular and smudged black horizontal lines

- Solution:** If the irregular smudged black lines occur cyclically, replace the toner cartridge. If they are non-cyclically, replace the fixing film unit.

Marks

- Solution:**
- (1) Copy a few white paper documents.
 - (2) If the marks is at intervals of approx. 3.70" (94 mm), replace the toner cartridge.
 - (3) If the marks is at intervals of approx. 2.97" (75 mm), clean the cassette separation roller.
 - (4) If the marks is at intervals of approx. 1.97" (50 mm), clean the feed roller and the pre-transfer roller.
 - (5) If the marks is at intervals of approx. 1.85" (47 mm), clean the transfer charging roller.
 - (6) If the marks is at intervals of approx. 2.95" (75 mm), clean the fixing film unit.
 - (7) Replace the cassette separation roller.
 - (8) Replace the feed roller.
 - (9) Replace the pre-transfer roller.
 - (10) Replace the transfer charging roller.
 - (11) Replace the fixing film unit.

Blank spots

- Solution:**
- (1) Clean the developing bias contact and the toner cartridge contact.
 - (2) Clean the transfer charging roller.
 - (3) Replace the toner cartridge.
 - (4) Replace the transfer charging roller.
 - (5) Replace the ECNT board.

White vertical lines

- Solution:**
- (1) Shake the toner cartridge.
 - (2) Clean the mirror.
 - (3) Check for foreign matter stuck in the laser output hole on the laser/scanner unit or the laser input hole on the toner cartridge.
 - (4) Clean the fixing entrance guide.
 - (5) Clean the fixing film unit.
 - (6) Replace the toner cartridge.
 - (7) Replace the fixing film unit.
 - (8) Replace the laser/scanner unit.

White horizontal lines

- Solution:**
- (1) Replace the toner cartridge.
 - (2) Replace the fixing film unit.

Faulty registration

- Solution:**
- (1) Check if more than the regulation amount of recording paper is loaded in the cassette.
 - (2) Clean the cassette pickup roller.
 - (3) Clean the multi-purpose tray pickup roller.
 - (4) Clean the feed roller.
 - (5) Adjust the leading edge margin as explained in *this Chapter, 4.4 Leading edge margin adjustment*.
 - (6) Replace the pickup roller.
 - (7) Replace the multi-purpose tray pickup roller.
 - (8) Replace the feed roller.
 - (9) Re-adjust the leading edge margin as explained in *this Chapter, 4.4 Leading edge margin adjustment*.
 - (10) Replace the ECNT board.

Poor fixing

- Solution:**
- (1) Check the nip width of the fixing ass'y. If it is not as specified, replace the fixing ass'y.
 - (2) If the dirt is at intervals of approx. 2.95" (75 mm), clean the fixing film unit.
 - (3) If the dirt is at intervals of approx. 2.48" (63 mm), clean the fixing pressure roller.
 - (4) Replace the fixing film unit.
 - (5) Replace the fixing pressure roller.

Distortion / nBD signal failure

- Solution:**
- (1) Check the laser/scanner unit (J401, J501, J551) and ECNT board (J53) connections.
 - (2) Replace the laser/scanner unit.
 - (3) Replace the ECNT board.

Partially compressed/stretched image

- Solution:**
- (1) Check the foreign matter between the toner cartridge gear and the printer drive gear.
 - (2) Check if the toner cartridge gear is not broken.
 - (3) Replace the toner cartridge.

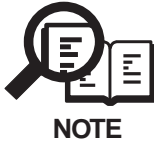

Checking the nip width of the pressure roller

The fixing unit is not designed to allow adjustment of the pressure (nip width); however, the incorrect nip width can cause fixing problems.

Follow the procedures below to check the nip width:

- (1) Either take along one or two all-black copies of A4 or letter size made with a copier, or make it using a copier at the customer site.
- (2) Place the all-black copy in the cassette of the printer, with the printed side facing down.
- (3) Open the face-up tray.
- (4) Press the test print switch (SW501) on the ECNT board.
- (5) When the leading edge of the print emerges at the face-up tray, turn OFF the printer. Take out the print from the printer about 10 seconds later.
- (6) Measure the width of the glossy band across the paper and check that it meets the requirements as shown in below table.

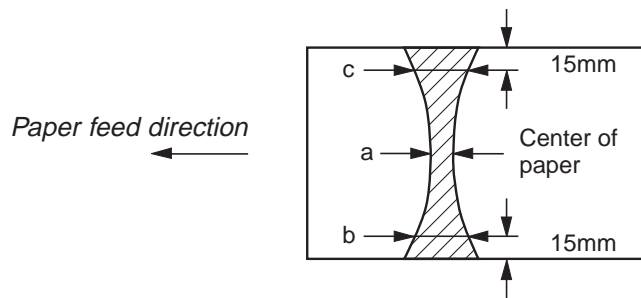

	Dimension
a	6 to 8 mm
b	6.3 to 8.3 mm
c	6.3 to 8.3 mm
b - c	1.0 mm or less
b - a	-0.3 mm or more
c - a	-0.3 mm or more

Figure 4-47 Fixing Nip Width

h) Recording paper pickup error

The recording paper is not picked up from the multi-purpose tray

- Solution:**
- (1) Check that the recording paper is not curled and is set correctly.
 - (2) Check if more than the regulation amount of recording paper is loaded in the multi-purpose tray.
 - (3) Clean the multi-purpose tray pickup roller.
 - (4) Check the pickup solenoid, pickup solenoid connector (J125, J126) and ECNT board (J56) connections.
 - (5) Check the resistance between multi-purpose tray pickup solenoid (J126-2) and (J126-3), which should be approx. 110 ohm. If it is not, replace the multi-purpose tray pickup solenoid.
 - (6) Check if the gears of the multi-purpose tray pick-up unit is not damaged.
 - (7) Replace the multi-purpose tray pickup roller.
 - (8) Replace the separation pad.
 - (9) Replace any damaged gears of the multi-purpose tray pick-up unit.
 - (10) If the FAX-L1000 Printer Kit is installed, make a test print from the multi-purpose tray. If the paper is picked up correctly, replace the FAX-L1000 Printer Kit.
 - (11) Replace the ECNT board.

Recording paper is not picked up from the cassette 1

- Solution:**
- (1) Check that the cassette 1 is installed correctly.
 - (2) Check if more than the regulation amount of recording paper is loaded in the cassette 1.
 - (3) Check that the cassette pickup roller is at its initial position. If it is not, after switch the power on, insert the cassette 1 into the main unit.
 - (4) Clean the cassette pickup roller, cassette feed roller and cassette separation roller.
 - (5) Check the cassette claw. If it is deformed, replace it.
 - (6) Check the cassette pickup solenoid and paper size detection board 1 (J604) connections.
 - (7) Check the resistance between cassette pickup solenoid (J604-1) and (J604-2), which should be approx. 110 ohm. If it is not, replace the cassette pickup solenoid.
 - (8) Check the pick-up module drive unit. If there are damaged parts, replace any damaged parts.
 - (9) Check the ECNT board (J72) and paper size detection board 1 (J603) connections.
 - (10) Replace the cassette pickup roller.
 - (11) Replace the cassette feed roller and cassette separation roller together.
 - (12) If the FAX-L1000 Printer Kit is installed, make a test print from the cassette 1. If the paper is picked up correctly, replace the FAX-L1000 Printer Kit.
 - (13) Replace the paper size detection board 1.
 - (14) Replace the ECNT board.

Recording paper is not picked up from the cassette 2 (Option paper feeder)

- Solution:**
- (1) Check that the cassette 2 is installed correctly.
 - (2) Check if more than the regulation amount of recording paper is loaded in the cassette 2.
 - (3) Check that the cassette pickup roller is at its initial position. If it is not, after switch the power on, insert the cassette 2 into the main unit.
 - (4) Clean the cassette pickup roller, cassette feed roller and cassette separation roller.
 - (5) Check the cassette claw. If it is deformed, replace it.
 - (6) Check the cassette pickup solenoid and paper size detection board 2 (J802) connections.
 - (7) Check the resistance between cassette pickup solenoid (J802-1) and (J802-2), which should be approx. 110 ohm. If it is not, replace the cassette pickup solenoid.
 - (8) Check the pick-up module drive unit. If there are damaged parts, replace any damaged parts.
 - (9) Check the option cassette paper size detection board 2 (J801), paper feeder connector (J811, J812, J104, J106) and paper size detection board 1 (J601) connections.
 - (10) Check the ECNT board (J72) and paper size detection board 1 (J603) connections.
 - (11) Replace the cassette pickup roller.
 - (12) Replace the cassette feed roller and cassette separation roller together.
 - (13) If the FAX-L1000 Printer Kit is installed, make a test print from the cassette 2. If the paper is picked up correctly, replace the FAX-L1000 Printer Kit.
 - (14) Replace the paper size detection boards.
 - (15) Replace the ECNT board.

i) Recording paper feed error

The recording paper is not fed between transfer and feed section

- Solution:**
- (1) When a paper 180mm or less in length is jammed before reaching the fixing roller, examine whether the paper is curled downward. If it is, straighten the paper, and then instruct the user.
 - (2) If the paper does not reach the registration arm, go to step (13) and thereafter.
 - (3) Clean the paper feed belt. If it is worn or damaged, replace it.
 - (4) If the paper feed belt drive gear is damaged, replace it.
 - (5) Clean the pre-transfer roller. If it is worn or deformed, replace it.
 - (6) Clean the registration arm. If it is worn or deformed, replace it.
 - (7) If the registration arm does not move smoothly, adjust the arm so that it moves smoothly.
 - (8) If the registration arm spring is out of place, re-attach it or replace it.
 - (9) If the top of page sensor lever does not move smoothly, adjust the lever so that it moves smoothly.
 - (10) If the top of page sensor lever is damaged, replace it.
 - (11) If the transfer charging roller does not move smoothly, replace the bushing.
 - (12) If the gear of the transfer charging roller is worn or damaged, replace it.
 - (13) Clean the feed roller. If the feed roller is worn or damaged, replace it.
 - (14) If the gears of the multi-purpose tray pick-up unit, replace any damaged gears.
 - (15) Check the resistance between feed roller clutch (J128-1) and (J128-2), which should be approx. 145 ohm. If it is not, replace the feed roller clutch.
 - (16) Replace the ECNT board.

The recording paper is not fed between fixing and delivery section

- Solution:**
- (1) If the nip width is not within the specification, replace the fixing ass'y.
 - (2) Clean the fixing entrance guide.
 - (3) If the recording paper eject sensor 2 lever does not move smoothly, adjust the lever so that it moves smoothly.
 - (4) If the recording paper eject sensor 2 lever is damaged, replace it.
 - (5) If the fixing pressure roller does not move smoothly, check the gears and replace if any worn or fractured gear is found.
 - (6) Clean the fixing film unit. If the fixing film unit is deformed or scarred, replace it.
 - (7) Clean the fixing pressure roller. If the fixing pressure roller is deformed or scarred, replace it.
 - (8) Clean the face-up deflector.
 - (9) Clean the fixing eject roller. If the fixing eject roller is worn or damaged, replace it.
 - (10) If the fixing eject roller does not move smoothly, check the gears and replace if any worn or fractured gear is found.
 - (11) If the paper feed roller is worn or damaged, replace it.
 - (12) If the paper feed roller does not move smoothly, check the gears and replace if any worn or fractured gear is found.
 - (13) If the face-down delivery roller is worn or damaged, replace it.
 - (14) If the face-down delivery roller does not move smoothly, check the gears and replace if any worn or fractured gear is found.
 - (15) If the recording paper overload sensor lever does not move smoothly, adjust the lever so that it moves smoothly.
 - (16) If the recording paper overload sensor lever is damaged, replace it.
 - (17) If the poor linkage between the recording paper eject sensor 1 lever on the fixing unit and the arm on the ECNT board, rejoin the fixing unit with the ECNT board properly.
 - (18) Replace the ECNT board.

Multiple feed

- Solution:**
- (1) If jams occur in the multi-purpose tray, go to step (7) and thereafter.
 - (2) Set the paper caught by the claw of the cassette.
 - (3) Check the cassette claw. If it is deformed, replace it.
 - (4) If the cassette separation roller is worn or deformed, replace the cassette feed roller and cassette separation roller together.
 - (5) If the spring pushing the cassette separation roller is defective, replace the spring.
 - (6) If the torque limiter of the cassette separation roller is defective, replace it.
 - (7) If the separation pad surface is worn, replace it.
 - (8) If the spring pushing separation pad, replace the spring.

Wrinkles/folded leading edge

- Solution:**
- (1) If the paper is curled, straighten the paper, and then instruct the user.
 - (2) Open the printer cover after the paper is picked up before it enters the fixing unit. If the paper is wrinkled or folded at its leading edge at this point, go to step (5) and thereafter.
 - (3) Clean the fixing entrance guide.
 - (4) Clean the fixing pressure roller. If the fixing pressure roller is deformed or scarred, replace it.
 - (5) Clean the fixing film unit. If the fixing film unit is deformed or scarred, replace it.
 - (6) Clean the registration arm. If it is worn or deformed, replace it.
 - (7) Clean the feed roller, pre-transfer roller and paper feed guide.
 - (8) If the transfer guide is worn, scarred or deformed, replace it.

Skew

- Solution:**
- (1) If the cassette feed roller and the cassette separation roller are worn unevenly, replace them together.
 - (2) If the cassette side plate ass'y (right and left side) do not move smoothly or are deformed, replace them.
 - (3) Clean the registration arm. If it is worn or deformed, replace it.
 - (4) If the registration arm does not move smoothly, adjust the arm so that it moves smoothly.
 - (5) If the registration arm spring is out of place, re-attach it or replace it.

j) Printer error

PRINTER ERROR MESSAGES

Solution: (1) For the detail of the printer error messages, refer to the *Chapter 5, 3.10 FAX-L1000 Printer Kit, 3.10.4 Maintenance and service, b) Troubleshooting*.

Main motor does not run

Solution: (1) Check the main motor, main motor connector (J301) and ECNT board (J52) connections.
(2) Replace the main motor.
(3) Replace the ECNT board.

6. WIRING DIAGRAM

6.1 Wiring Diagram

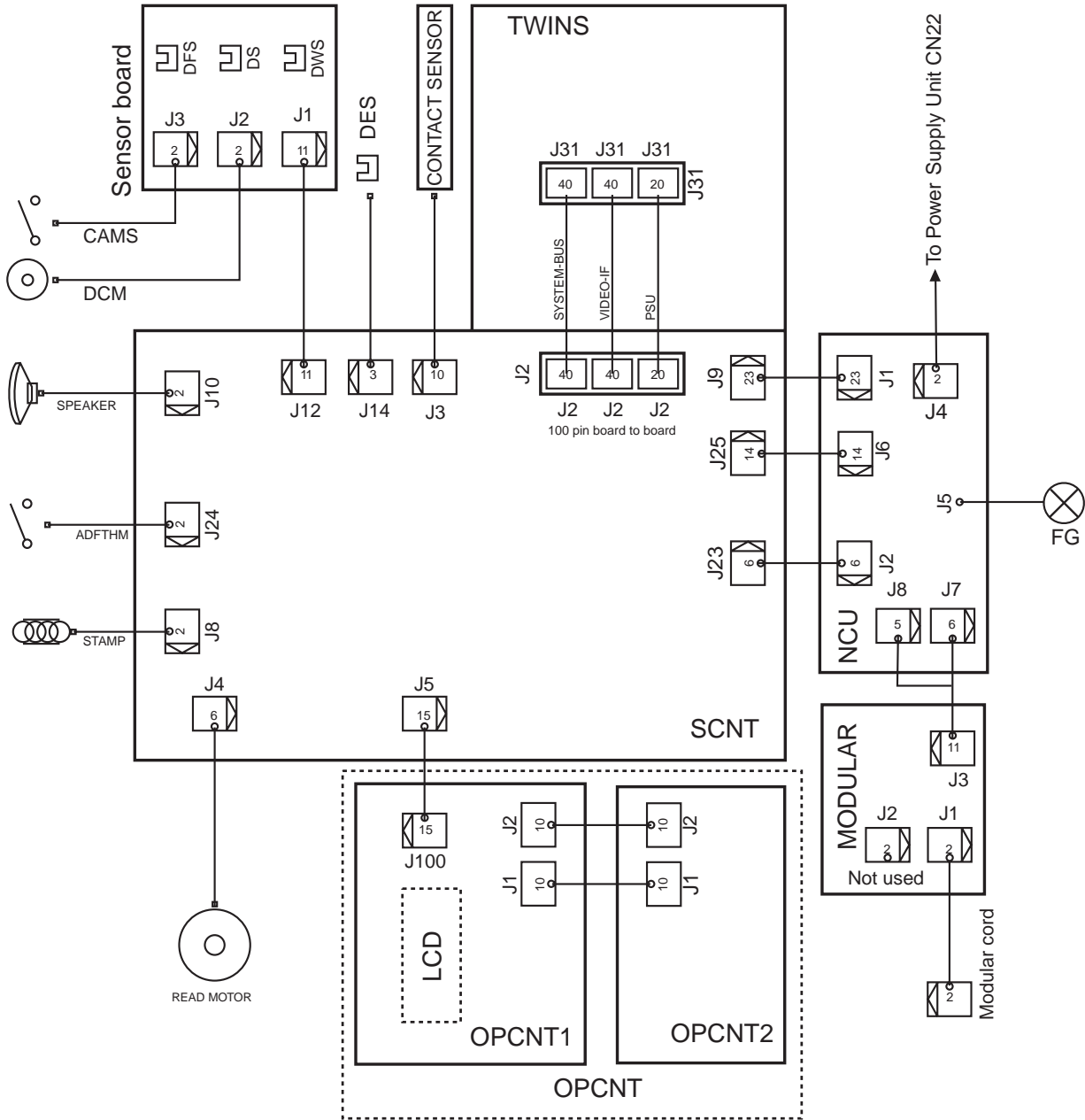

Figure 4-48 Wiring Diagram (1)

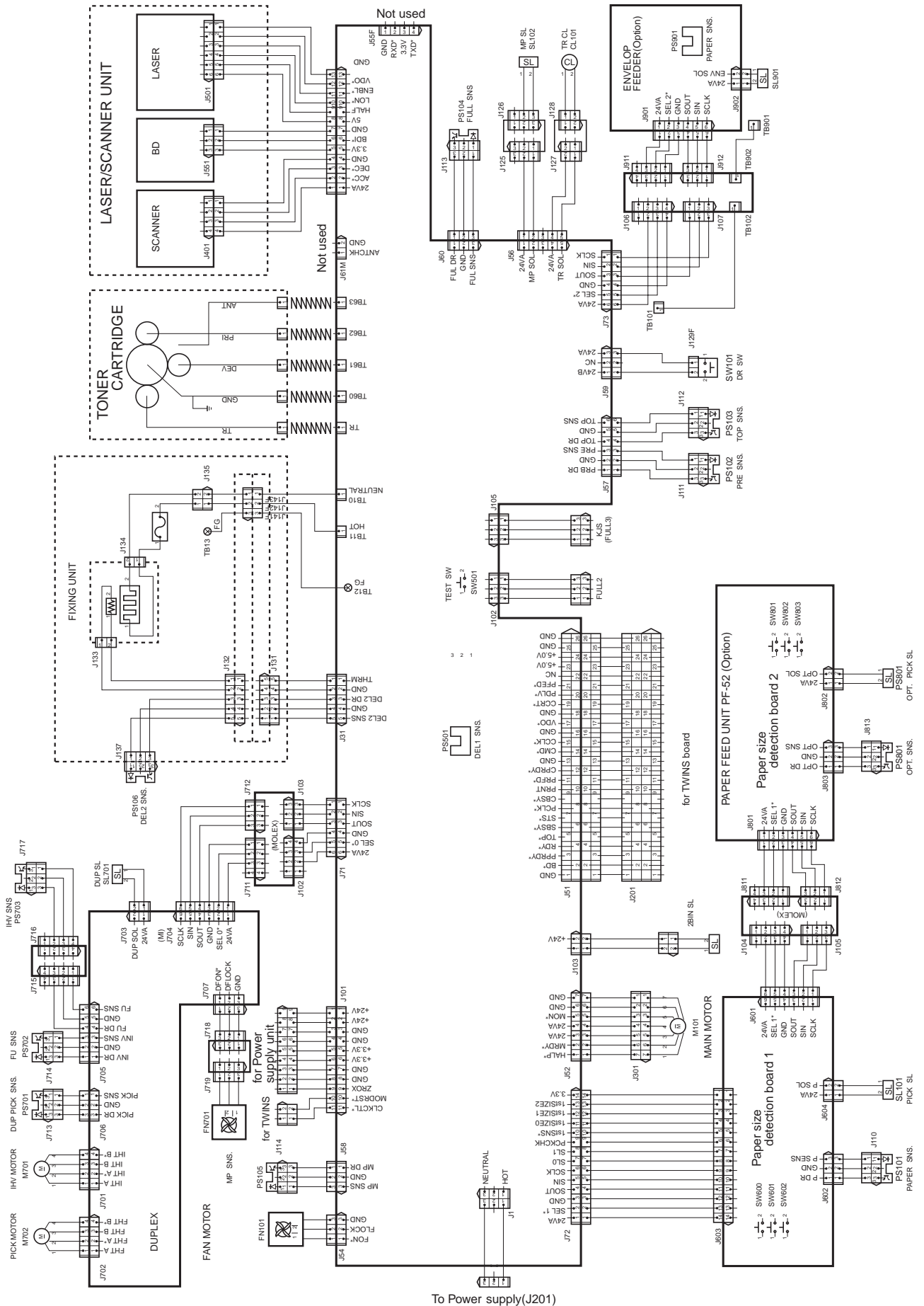

Figure 4-49 Wiring Diagram (2)

6.2 Signal Description

SCNT board (J1) ↔ Memory board

J1	Memory	Signal name	Description
A1	— 1	DGND	Ground
A2	— 2	VD0	Data signal
A3	— 3	VD1	Data signal
A4	— 4	VD2	Data signal
A5	— 5	VD3	Data signal
A6	— 6	VD4	Data signal
A7	— 7	VD5	Data signal
A8	— 8	VD6	Data signal
A9	— 9	VD7	Data signal
A10	→ 10	+VB	Logic drive voltage
A11	— 11	N.C	Not connected
A12	— 12	AX0	Address/data signal
A13	— 13	AX1	Address/data signal
A14	— 14	AX2	Address/data signal
A15	— 15	AX3	Address/data signal
A16	— 16	AX4	Address/data signal
A17	— 17	AX5	Address/data signal
A18	— 18	AX6	Address/data signal
A19	— 19	AX10	Address/data signal
A20	— 20	N.C	Not connected
A21	— 21	VD8	Data signal
A22	— 22	VD9	Data signal
A23	— 23	VD10	Data signal
A24	— 24	VD11	Data signal
A25	— 25	VD12	Data signal
A26	— 26	VD13	Data signal
A27	— 27	VD14	Data signal
A28	— 28	AX7	Address/data signal
A29	— 29	N.C	Not connected
A30	→ 30	+VB	Logic drive voltage
A31	— 31	AX8	Address/data signal
A32	— 32	AX9	Address/data signal
A33	— 33	N.C	Not connected
A34	— 34	N.C	Not connected
A35	— 35	VD15	Data signal
A36	— 36	N.C	Not connected
A37	— 37	VD0	Data signal
A38	— 38	VD1	Data signal
A39	— 39	DGND	Ground
A40	→ 40	nCASL	Column address/low-order byte access
A41	→ 41	nCASL	Column address/low-order byte access
A42	→ 42	nCASH	Column address/high-order byte access

SCNT board (J1) ↔ Memory board

J1	Memory	Signal name	Description
A43 →	43	nCASH	Column address/high-order byte access
A44 →	44	nRAS2	Row address strobe signal No.2
A45 —	45	N.C	Not connected
A46 —	46	N.C	Not connected
A47 →	47	nFWE	XWE signal to DRAM
A48 —	48	N.C	Not connected
A49 —	49	VD2	Data signal
A50 —	50	VD3	Data signal
A51 —	51	VD4	Data signal
A52 —	52	VD5	Data signal
A53 —	53	VD6	Data signal
A54 —	54	VD7	Data signal
A55 —	55	N.C	Not connected
A56 —	56	VD8	Data signal
A57 —	57	VD9	Data signal
A58 —	58	VD10	Data signal
A59 —	59	VD12	Data signal
A60 —	60	VD11	Data signal
A61 →	61	+VB	Logic drive voltage
A62 —	62	VD13	Data signal
A63 —	63	VD14	Data signal
A64 —	64	VD15	Data signal
A65 —	65	N.C	Not connected
A66 —	66	N.C	Not connected
A67 —	67	N.C	Not connected
A68 —	68	N.C	Not connected
A69 —	69	N.C	Not connected
A70 —	70	N.C	Not connected
A71 —	71	N.C	Not connected
A72 —	72	DGND	Ground



NOTE

The J1 connector on the SCNT board has two rows A and B and has a total of 144 pins. Since rows A and B have similar pin layout, only different pins are shown below:

B34 :nRAS2 B44 :nRAS1

SCNT board (J2) ↔ TWINS board (J31)

J2	J31	Signal name	Description
1	→ 1	VA5	Address signal
2	→ 2	VA4	Address signal
3	→ 3	VA3	Address signal
4	→ 4	VA2	Address signal
5	→ 5	VA1	Address signal
6	→ 6	VA0	Address signal
7	— 7	DGND	Ground
8	— 8	VD7	Data signal
9	— 9	VD6	Data signal
10	— 10	VD5	Data signal
11	— 11	VD4	Data signal
12	— 12	DGND	Ground
13	← 13	INTPIFI1	Interrupt signal 1
14	← 14	INTPIFI2	Interrupt signal 2
15	→ 15	VUBE	Upper Bite Enable
16	← 16	+5V	Logic drive voltage
17	→ 17	ALLRST	All reset signal
18	→ 18	CLKCTK	Clock control signal
19	→ 19	TC	Terminal count
20	→ 20	DACK2	DMA acknowledge signal 2
21	→ 21	DACK5	DMA acknowledge signal 5
22	← 22	DREQ2	DMA request signal 2
23	← 23	DREQ5	DMA request signal 5
24	← 24	OPTION0	Option board detection signal 0
25	← 25	OPTION1	Option board detection signal 1
26	— 26	DGND	Ground
27	← 27	PPRDY	Printer power ready signal
28	← 28	TOP	Top of page signal
29	← 29	STS	Status signal
30	→ 30	CBSY	Command busy signal
31	→ 31	PRFD	Pre-Feed signal
32	— 32	DGND	Ground
33	→ 33	CCLK	Controller clock signal
34	→ 34	VDO	Printer video signal
35	→ 35	CCRT	Condition change report signal
36	→ 36	MODRST	Modem reset signal
37	← 37	+5V	Logic drive voltage
38	← 38	OPTION2	Option board detection signal 2
39	← 39	SCEN	Printer panel data receive enable signal
40	→ 40	CSITX	Printer panel data transmission signal
41	← 41	+12V	+12V
42	— 42	AGND	Analog ground
43	← 43	+24V	+24V

SCNT board (J2) ↔ TWINS board (J31)

J2		J31	Signal name	Description
44	←	44	+24V	+24V
45	←	45	DGND	Ground
46	←	46	+5V	+5V
47	→	47	+5V	+5V(off while ESS)
48	—	48	DGND	Ground
49	→	49	+3.3V	+3.3V
50	—	50	DGND	Ground
51	—	51	VD15	Data signal
52	—	52	VD14	Data signal
53	—	53	VD13	Data signal
54	—	54	VD12	Data signal
55	—	55	DGND	Ground
56	—	56	VD11	Data signal
57	—	57	VD10	Data signal
58	—	58	VD9	Data signal
59	—	59	VD8	Data signal
60	—	60	DGND	Ground
61	—	61	VD3	Data signal
62	—	62	VD2	Data signal
63	—	63	VD1	Data signal
64	—	64	VD0	Data signal
65	←	65	+5V	+5V
66	←	66	ESSACT	ESSACT
67	→	67	FIORD	I/O read signal
68	→	68	FIOWR	I/O write signal
69	—	69	DGND	Ground
70	→	70	ICS7	Chip select signal 7
71	→	71	VTC	V terminal count
72	→	72	VACK1	VACK1
73	←	73	VREQ1	VREQ1
74	→	74	ICS5	Chip select signal 5
75	←	75	OPTSPK	Option board speaker signal
76	←	76	BD	Beam detection signal
77	←	77	RDY	Ready signal
78	←	78	SBSY	Status busy signal
79	←	79	+3.3V	+3.3V(off while ESS)
80	→	80	PRNT	Print signal
81	→	81	CPRDY	Controller power ready signal
82	→	82	CMD	Command signal
83	←	83	G4CI	G4 board CI signal
84	—	84	DGND	Ground
85	←	85	OPTION4	Option board detection signal 4
86	→	86	PRESS	ESS printer reset control signal

SCNT board (J2) ↔ TWINS board (J31)

J2		J31	Signal name	Description
87	←	87	+5V	+5V
88	←	88	OPTION3	Option board detection signal 3
89	←	89	PCLK	Printer panel data transfer clock
90	←	90	CSIRX	Printer panel data receive signal
91	←	91	+12V	+12V
92	→	92	AGND	Analog ground
93	←	93	+24V	+24V
94	←	94	+24V	+24V
95	—	95	DGND	Ground
96	←	96	+5V	+5V
97	→	97	+5V	+5V(off while ESS)
98	—	98	DGND	Ground
99	→	99	+3.3V	+3.3V
100	→	100	PWCTL	Power control signal

SCNT board (J3) ↔ Contact sensor

J3		Contact sensor	Signal name	Description
1	←	1	VOUT	Scanner video signal
2	—	2	AGND	Analog ground
3	→	3	+5V	+5V(Contact sensor)
4	←	4	+ref	Reference
5	—	5	DGND	Ground
6	→	6	SP	Shift pulse
7	→	7	FGND	Frame ground
8	→	8	MACLK	Contact sensor drive clock
9	→	9	LEDON	LED drive control
10	→	10	+24V	+24V

SCNT board (J4) ↔ Document feed motor

J4		Motor	Signal name	Description
1	→	1	PHA	Phase A
2	→	2	PHB	Phase B
3	—	3	Commongnd	Common ground
4	—	4	Commongnd	Common ground
5	→	5	PHXA	Phase \bar{A}
6	→	6	PHXB	Phase \bar{B}

SCNT board (J5) ↔ OPCNT board 1(J100)

J5		J100	Signal name	Description
1	→	18	+5V	+5V
2	→	17	+5V	+5V
3	→	16	ESSLED	ESS LED drive signal
4	←	15	ESSKEY	ESS key input signal
5	←	14	PRTCT	SRAM protect signal
6	←	13	PNLRX	Panel data receive signal
7	—	12	DGND	Ground
8	→	11	PNLCK	Panel data transmission clock
9	—	10	DGND	Ground
10	→	9	PNLTX	Panel data transmission signal
11	—	8	DGND	Ground
12	→	7	ALLRST	System reset signal
13	←	6	PRNKEY0	Printer panel key 0
14	←	5	PRNKEY1	Printer panel key 1
15	←	4	PRNKEY2	Printer panel key 2
16	←	3	PRNKEY3	Printer panel key 3
17	←	2	PRNKEY4	Printer panel key 4
18	←	1	PRNKEY5	Printer panel key 5

SCNT board (J8) ↔ STAMP unit

J8		STAMP	Signal name	Description
1	→	1	STAMP+24V	STAMP+24V
2	→	2	STAMPGND	STAMP ground

SCNT board (J9) ↔ NCU board (J1)

J9		J1	Signal name	Description
1	—	23	DGND	Ground
2	←	22	BIT3	for future use
3	←	21	BIT2	for future use
4	←	20	BIT1	for future use
5	—	19	LPL2	Not used
6	—	18	LPL1	Not used
7	—	17	HOOK2	Not used
8	←	16	HOOK1	Off hook detection signal
9	←	15	CIOR	CIOR signal 1
10	←	14	CI2	CI detection signal 2
11	←	13	CI1	CI detection signal 1
12	—	12	LPRD	Not used
13	→	11	DCD	DC relay control signal
14	→	10	CMLD	CML relay control signal
15	→	9	HRD	H relay control signal
16	→	8	PRD	P relay control signal
17	→	7	SRD	S relay control signal
18	—	6	DGND	Ground
19	—	5	DGND	Ground
20	→	4	VH	+24V DC
21	→	3	+3.3V	Logic drive voltage
22	→	2	+3.3V	Logic drive voltage
23	—	1	DGND	Ground

SCNT board (J10) ↔ SPEAKER

J10		Speaker	Signal name	Description
1	→	1	SPKO2	Speaker out 2
2	→	2	SPKO1	Speaker out 1

SCNT board (J12) ↔ Sensor board(J1)

J12		(J1)	Signal name	Description
1	→	11	+3.3V	+3.3V(off while ESS)
2	—	10	DGND	Ground
3	—	9	DGND	Ground
4	←	8	DWS	Document width sensor detect signal (H: No document, L: Document)
5	→	7	SENPW	Sensor power
6	←	6	DS	Document sensor detect signal (H: No document, L: Document)
7	←	5	DFS	Document feed sensor detect signal (H: No document, L: Document)
8	←	4	CAMS	Cam sensor signal
9	→	3	DCMGND	DC motor ground
10	→	2	DCMGND	DC motor ground
11	→	1	DCM+18V	DC motor +18V

SCNT board (J14) ↔ Document edge sensor

J14		Sensor	Signal name	Description
1	→	—	+5V	+5V(DES)
2	—	—	DGND	Ground
3	←	—	DES	Document edge sensor detect signal (H: No document, L: Document)

SCNT board (J23) ↔ NCU board(J2)

J23		J2	Signal name	Description
1	—	6	DGND	Ground
2	→	5	+12V	+12V
3	→	4	+12V	+12V
4	←	3	ANOUT	Analog out signal
5	→	2	TXAO	Analog transmission signal
6	←	1	RXAI	Analog receive signal

SCNT board (J24) ↔ ADF thermostat

J24		ADF thm	Signal name	Description
1	→	1	ADFTHM+24V	ADF Thermostat +24V out
2	←	2	ADFGND	ADF Thermostat +24V in

SCNT board (J25) ↔ NCU board (J6)

J25		J6	Signal name	Description
1	—	14	OUT	Direct current of line detection signal
2	→	13	IPSEL1	HIC terminal impedance setting
3	→	12	IPSEL2	HIC terminal impedance setting
4	—	11	IPSEL3	HIC terminal impedance setting
5	→	10	DCSEL	DC registance switching when line is connected
6	←	9	DCLIM	DC current limitation control signal
7	←	8	RRD	R relay control signal
8	←	7	NOR	CI reception sensitivity setting signal when no ringing reception
9	←	6	C1	DC cut capacitor selection signal
10	←	5	C2	DC cut capacitor selection signal
11	←	4	CIST1	CI reception sensitivity setting signal
12	←	3	CIST2	CI reception sensitivity setting signal
13	←	2	AST	For Australian regulations signal
14	←	1	NZ	For N.Z. regulations signal

NCU board (J4) ↔ Power Supply unit (CN22)

J4		CN22	Signal name	Description
1	←	2	VH	For off-hook detection during communication
2	—	1	VH-GND	Ground

NCU board (J5) ↔ to Grounding wire

J5		G.wire	Signal name	Description
1	—	—	ARG	Ground (arrester)

NCU board (J7) ↔ Modular board (J3)

J7		J3	Signal name	Description
1	—	6	T2	Line from L1, L2 to wall socket via the fax
2	—	5	W	Line from handset terminal T11 in priority mode (handset/extension telephone).
3	—	4	L2	Telephone line
4	—	3	L1	Telephone line
5	—	2	R	Outside line access signal
6	—	1	T1	Line from L1, L2 to wall socket via the fax

NCU board (J8) ↔ Modular board (J3)

J5	G.wire	Signal name	Description
1	— 11	A	Line from handset terminal T12 in priority mode (handset/extension telephone).
2	— 10	W	Line from handset terminal T11 in priority mode (handset/extension telephone).
3	— 9	T12	Handset terminal telephone line via the fax
4	— 8	T11	Handset terminal telephone line via the fax
5	— 7	R	Outside line access signal

NCU board (J9) ↔ Not connected

J9	Signal name	Description
1	— — N.C	Not connected
2	— — N.C	Not connected
3	— — N.C	Not connected
4	— — N.C	Not connected

Modular board (J1) ↔ LINE

J1	LINE	Signal name	Description
1	— —	T1	Line from L1, L2 to wall socket via the fax
2	— —	R	Outside line access signal
3	— —	L1	Telephone line
4	— —	L2	Telephone line
5	— —	W	Line from handset terminal T11 in priority mode(handset/extension telephone).
6	— —	T2	Line from L1, L2 to wall socket via the fax

Modular board (J2) ↔ Not connected

J2	HANDSET	Signal name	Description
1	— —	N.C	Not connected
2	— —	R	Not connected
3	— —	T11	Not connected
4	— —	T12	Not connected
5	— —	W	Not connected
6	— —	A	Not connected

ECNT board (J101) ↔ Power supply unit

J101		PSU	Signal name	Description
1	←	1	HOT	AC power input
2	←	2	NEUTRAL	AC power input

ECNT board (J31) ↔ Fixing unit(J131)

J31		J131	Signal name	Description
1	←	1	THRM	Thermistor signal
2	—	2	DGND	Ground
3	—	3	DEL2 DR	Fixing unit delivery sensor 2 drive
4	—	4	DGND	Ground
5	←	5	nDELSNS2	Fixing unit delivery detection signal 2

ECNT board (J51) ↔ TWINS board(J32)

J51		J32	Signal name	Description
1	—	1	DGND	Ground
2	→	2	nBD	Beam detection signal
3	←	3	nPPRDY	Printer power ready signal
4	→	4	nRDY	Ready signal
5	→	5	nTOP	Top of page signal
6	→	6	nSBSY	Status busy signal
7	→	7	nSTS	Status signal
8	→	8	nPCLK	Printer clock signal
9	←	9	nCBSY	Command busy signal
10	←	10	nPRINT	Print signal
11	←	11	nPRFD	Pre-feed signal
12	←	12	nCPRDY	Controller power ready signal
13	—	13	DGND	Ground
14	←	14	nCMD	Command signal
15	←	15	nCCLK	Controller clock signal
16	—	16	DGND	Ground
17	←	17	nVDO	Printer video signal
18	—	18	DGND	Ground
19	→	19	nCCRT	Condition change report signal
20	—	20	N.C.	Not connected
21	—	21	N.C.	Not connected
22	←	22	nPRESS	ESS printer reset control signal
23	→	23	+5V	Logic drive voltage
24	→	24	+5V	Logic drive voltage
25	—	25	DGND	Ground
26	—	26	DGND	Ground

ECNT board (J52) ↔ Main motor(J301)

J52	J301	Signal name	Description
1 →	7	nHALF	Main motor speed switching signal
2 ←	6	nMRDY	Main motor ready signal
3 →	5	+24V	Main motor drive voltage
4 →	4	+24V	Main motor drive voltage
5 →	3	nMON	Main motor drive signal
6 —	2	DGND	Ground
7 —	1	DGND	Ground

ECNT board (J53) ↔ Laser/scanner unit scanner section(J401)

J53	J401	Signal name	Description
1 →	4	+24V	Scanner motor drive voltage
2 →	3	nACC	Scanner motor acceleration signal
3 →	2	nDEC	Scanner motor deceleration signal
4 —	1	DGND	Ground

ECNT board (J53) ↔ Laser/scanner unit BD section(J551)

J53	J551	Signal name	Description
5 →	3	+3.3V	Logic drive voltage
6 ←	2	nBDI	BD input signal
7 —	1	DGND	Ground

ECNT board (J53) ↔ Laser/scanner unit Laser section(J501)

J53	J501	Signal name	Description
8 →	6	+5V	Logic drive voltage
9 →	5	HALF	Laser intensity switching signal
10 →	4	nLON	Laser forced emission signal
11 →	3	nENBL	Video data enable signal
12 →	2	nVDO	Printer video signal
13 →	1	DGND	Ground

ECNT board (J54) ↔ FAN

J54	FAN	Signal name	Description
1 →	1	nFON	Fan drive signal
2 →	2	FLOCK	Fan lock detection signal
3 —	3	DGND	Ground

ECNT board (J55F) ↔ Not used

J55F			Signal name	Description
1	—	—	DGND	Not connected
2	←	—	RxD	Not connected
3	→	—	+3.3V	Not connected
4	→	—	TxD	Not connected

ECNT board (J56) ↔ MP tray pick-up solenoid(J125)

J56		J125	Signal name	Description
1	→	1	+24V	Multi-purpose tray pick-up solenoid drive voltage
2	→	2	MP SOL	Multi-purpose tray pick-up solenoid drive signal
3	—	3	N.C.	Not connected

ECNT board (J56) ↔ Feed roller clutch(J127)

J56		J127	Signal name	Description
4	→	2	+24V	Feed roller clutch drive voltage
5	→	1	TRCL	Feed roller clutch drive signal

ECNT board (J57) ↔ Pre-feed sensor(J111)

J57		J111	Signal name	Description
1	→	3	PRE DR	Pre-feed sensor drive
2	—	2	DGND	Ground
3	←	1	nPRE SNS	Pre-feed detection signal (H: No recording paper, L: Recording paper)

ECNT board (J57) ↔ Top of page sensor(112)

J57		J112	Signal name	Description
4	→	3	TOP DR	Top of page sensor drive
5	—	2	DGND	Ground
6	←	1	nTOP SNS	Top of page detection signal (H: No recording paper, L: Recording paper)

ECNT board (J58) ↔ Multi-purpose tray detection sensor(J114)

J58		J114	Signal name	Description
1	→	3	MP DR	Multi-purpose tray paper sensor drive
2	—	2	DGND	Ground
3	←	1	nMP SNS	Multi-purpose tray paper detection signal (H: No recording paper, L: Recording paper)

ECNT board (J59) ↔ Printer cover sensor (J119F)

J59		J119F	Signal name	Description
1	→	2	+24VA	Printer cover sensor drive voltage
2	—	—	N.C.	Not connected
3	←	1	+24VB	24VB supply and top cover detection signal (H: Close, L: Open)

ECNT board (J60) ↔ Recording paper overload sensor 1 (J113)

J60		J113	Signal name	Description
1	→	1	FUL DR	Recording paper overload sensor 1 drive signal
2	—	2	DGND	Ground
3	←	3	nFUL SNS	Recording paper overload detection signal

ECNT board (J61M) ↔ Toner sensor (Not used)

J61M			Signal name	Description
1	←	—	ANT	Not connected
2	—	—	DGND	Not connected

ECNT board (J71) ↔ Duplexing unit(J103)

J71		J103	Signal name	Description
1	→	3	SCLK	Serial clock signal
2	→	2	SIN	Serial input data
3	←	1	SOUT	Serial output data

ECNT board (J71) ↔ Duplexing unit(J102)

J71		J102	Signal name	Description
4	—	4	DGND	Ground
5	→	3	nSEL0	Duplexing unit select signal
6	→	2	+24V	Duplexing unit drive voltage
—	—	1	N.C.	Not connected

ECNT board (J72) ↔ Paper size board(J603)

J72		J603	Signal name	Description
1	→	14	+24V	Pick-up solenoid drive voltage
2	→	13	nSEL1	Paper feed select signal
3	—	12	GND	Ground
4	→	11	SOUT	Serial output data
5	←	10	SIN	Serial input data
6	→	9	SCLK	Serial clock signal
7	→	8	SLO	Cassette 1 pick-up solenoid drive signal

ECNT board (J72) ↔ Paper size board(J603)

J72		J603	Signal name	Description
8	→	7	SL1	Pick-up module identification signal 1 Lower cassette pick-up solenoid drive signal
9	→	6	PCKCHK	Pick-up module identification signal 1 Upper/lower cassette selection signal
10	←	5	n1st SNS	Cassette paper detection signal (H: No recording paper, L: Recording paper)
11	←	4	1st SIZE0	Cassette paper size detection signal
12	←	3	1st SIZE1	Cassette paper size detection signal
13	←	2	1st SIZE2	Cassette paper size detection signal
14	→	1	+3.3V	Logic drive voltage

ECNT board (J73) ↔ Envelope feeder(J107)

J73		J107	Signal name	Description
1	→	3	SCLK	Serial clock signal
2	←	2	SIN	Serial input data
3	—	1	SOUT	Serial output data

ECNT board (J73) ↔ Envelope feeder(J106)

J73		J106	Signal name	Description
4	—	4	DGND	Ground
5	←	3	nSEL2	Envelope feeder select signal
6	→	2	+24V	Envelope feeder drive voltage
—	—	1	N.C	Not connected

ECNT board (J101) ↔ Power supply unit(J203)

J101		J203	Signal name	Description
1	→	9	+24V	Logic drive voltage
2	→	8	+24V	Logic drive voltage
3	—	7	DGND	Ground
4	—	6	DGND	Ground
5	→	5	+3.3V	Logic drive voltage
6	→	4	+3.3V	Logic drive voltage
7	—	3	DGND	Ground
8	—	2	DGND	Ground
9	→	1	nZEROX	Zero cross signal

ECNT board (J101) ↔ TWINS board(J42)

J101			Signal name	Description
10	←	1	MODRST	Modem reset signal
11	←	2	CLKCTL	Clock control signal

ECNT board (J102) ↔ Recording paper overload sensor 2

J102	Sensor		Signal name	Description
1	→	1	FUL2DR	Recording paper overload sensor 2 drive signal
2	←	2	FULL2	Recording paper overload detection signal
3	—	3	DGND	Ground

ECNT board (J103) ↔ 2bin solenoid

J103	Solenoid		Signal name	Description
1	→	2	2BINSL DR	2bin solenoid drive signal
2	→	1	+24V	2bin solenoid drive voltage

ECNT board (J105) ↔ Recording paper overload release sensor

J72	Sensor		Signal name	Description
1	→	1	FUL3DR	Recording paper overload release sensor drive signal
2	←	2	FULL3	Recording paper overload release detection signal
3	—	3	DGND	Ground

TWINS board (J31) ↔ SCNT board (J2)

J31	J2		Signal name	Description
1	←	1	VA5	Address signal
2	←	2	VA4	Address signal
3	←	3	VA3	Address signal
4	←	4	VA2	Address signal
5	←	5	VA1	Address signal
6	←	6	VA0	Address signal
7	—	7	DGND	Ground
8	—	8	VD7	Data signal
9	—	9	VD6	Data signal
10	—	10	VD5	Data signal
11	—	11	VD4	Data signal
12	—	12	DGND	Ground
13	→	13	INTPIFI1	Interrupt signal 1
14	→	14	INTPIFI2	Interrupt signal 2
15	←	15	VUBE	Upper bite enable
16	→	16	+5V	Logic drive voltage
17	←	17	ALLRST	All reset signal

TWINS board (J31) ↔ SCNT board (J2)

J31		J2	Signal name	Description
18	←	18	CLKCTK	Clock control signal
19	←	19	TC	Terminal count
20	←	20	DACK2	DMA acknowledge signal 2
21	←	21	DACK5	DMA acknowledge signal 5
22	→	22	DREQ2	DMA request signal 2
23	→	23	DREQ5	DMA request signal 5
24	→	24	OPTION0	Option board detection signal 0
25	→	25	OPTION1	Option board detection signal 1
26	—	26	DGND	Ground
27	→	27	PPRDY	Printer power ready signal
28	→	28	TOP	Top of page signal
29	→	29	STS	Status signal
30	←	30	CBSY	Command busy signal
31	←	31	PRFD	Pre-Feed signal
32	—	32	DGND	Ground
33	←	33	CCLK	Controller clock signal
34	←	34	VDO	Printer video signal
35	←	35	CCRT	Condition change report signal
36	←	36	MODRST	MODRST
37	→	37	+5V	Logic drive voltage
38	→	38	OPTION2	Option board detection signal 2
39	→	39	SCEN	Printer panel data receive enable signal
40	←	40	CSITX	Printer panel data transmission signal
41	→	41	+12V	+12V
42	—	42	AGND	Analog ground
43	→	43	+24V	+24V
44	→	44	+24V	+24V
45	→	45	DGND	Ground
46	→	46	+5V	+5V
47	←	47	+5V	+5V(off while ESS)
48	—	48	DGND	Ground
49	←	49	+3.3V	+3.3V
50	—	50	DGND	Ground
51	—	51	VD15	Data signal
52	—	52	VD14	Data signal
53	—	53	VD13	Data signal
54	—	54	VD12	Data signal
55	—	55	DGND	Ground
56	—	56	VD11	Data signal
57	—	57	VD10	Data signal
58	—	58	VD9	Data signal
59	—	59	VD8	Data signal
60	—	60	DGND	Ground

TWINS board (J31) ↔ SCNT board (J2)

J31		J2	Signal name	Description
61	—	61	VD3	Data signal
62	—	62	VD2	Data signal
63	—	63	VD1	Data signal
64	—	64	VD0	Data signal
65	→	65	+5V	+5V
66	→	66	ESSACT	ESSACT
67	←	67	FIORD	IO read signal
68	←	68	FIOWR	IO write signal
69	—	69	DGND	Ground
70	←	70	ICS7	Chip select signal 7
71	←	71	VTC	V terminal count
72	←	72	VACK1	VACK1
73	→	73	VREQ1	VREQ1
74	←	74	ICS5	Chip select signal 5
75	→	75	OPTSPK	Option board speaker signal
76	→	76	BD	Beam detection signal
77	→	77	RDY	Ready signal
78	→	78	SBSY	Status busy signal
79	→	79	+3.3V	+3.3V(off while ESS)
80	←	80	PRNT	Print signal
81	←	81	CPRDY	Controller power ready signal
82	←	82	CMD	Command signal
83	→	83	G4CI	G4board CI signal
84	—	84	DGND	Ground
85	→	85	OPTION4	Option board detection signal 4
86	←	86	PRESS	ESS printer reset control signal
87	→	87	+5V	+5V
88	→	88	OPTION3	Option board detection signal 3
89	→	89	PCLK	Printer panel data transfer clock
90	→	90	CSIRX	Printer panel data receive signal
91	→	91	+12V	+12V
92	—	92	AGND	Ground
93	→	93	+24V	+24V
94	→	94	+24V	+24V
95	—	95	DGND	Ground
96	→	96	+5V	+5V
97	←	97	+5V	+5V(off while ESS)
98	—	98	DGND	Ground
99	←	99	+3.3V	+3.3V
100	←	100	PWCTL	Power control signal

TWINS board(J32) ←→ ECNT board (J51)

J32		J51	Signal name	Description
1	—	1	DGND	Ground
2	←	2	nBD	Beam detection signal
3	→	3	nPPRDY	Printer power ready signal
4	←	4	nRDY	Ready signal
5	←	5	nTOP	Top of page signal
6	←	6	nSBSY	Status busy signal

TWINS board(J32) ←→ ECNT board (J51)

J32		J51	Signal name	Description
7	←	7	nSTS	Status signal
8	←	8	nPCLK	Printer clock signal
9	→	9	nCBSY	Command busy signal
10	→	10	nPRINT	Print signal
11	→	11	nPRFD	Pre-feed signal
12	→	12	nCPRDY	Controller power ready signal
13	—	13	DGND	Ground
14	→	14	nCMD	Command signal
15	→	15	nCCLK	Controller clock signal
16	—	16	DGND	Ground
17	→	17	nVDO	Printer video signal
18	—	18	DGND	Ground
19	←	19	nCCRT	Condition change report signal
20	—	20	N.C.	Not connected
21	—	21	N.C.	Not connected
22	→	22	nPRESS	ESS printer reset control signal
23	←	23	+5V	Logic drive voltage
24	←	24	+5V	Logic drive voltage
25	—	25	DGND	Ground
26	—	26	DGND	Ground

TWINS board(J33) ←→ FAX-L1000 Printer kit (J2)

J33		J2	Signal name	Description
1	—	c26	DGND	Ground
2	—	c25	DGND	Ground
3	→	c24	+5V	Logic drive voltage
4	→	c23	+5V	Logic drive voltage
5	←	c22	nPRESS	ESS printer reset control signal
6	—	c21	N.C.	Not connected
7	—	c20	N.C.	Not connected
8	→	c19	nCCRT	Condition change report signal
9	—	c18	DGND	Ground
10	←	c17	nVDO	Printer video signal

TWINS board(J33) ↔ FAX-L1000 Printer kit (J2)

J33	J2	Signal name	Description	
11	—	c16	DGND	Ground
12	←	c15	nCCLK	Controller clock signal
13	←	c14	nCMD	Command signal
14	—	c13	DGND	Ground
15	←	c12	nCPRDY	Controller power ready signal
16	←	c11	nPRFD	Pre-feed signal
17	←	c10	nPRINT	Print signal
18	←	c9	nCBSY	Command busy signal
19	→	c8	nPCLK	Printer clock signal
20	→	c7	nSTS	Status signal
21	→	c6	nSBSY	Status busy signal
22	→	c5	nTOP	Top of page signal
23	→	c4	nRDY	Ready signal
24	←	c3	nPPRDY	Printer power ready signal
25	→	c2	nBD	Beam detection signal
26	—	c1	DGND	Ground

TWINS board(J34) ↔ FAX-L1000 Printer kit (J2)

J34	J2	Signal name	Description	
1	—	b10	GND	Ground
2	—	b9	N.C	Not connected
3	—	b8	GND	Ground
4	→	b7	PNL-RD	Panel read data signal
5	←	b6	PNL-WD	Panel write data signal
6	—	b5	nDENB	Not connected
7	←	b4	COM/nDAT	PDL write data command/data signal (H:cCommand L:Data)
8	←	b3	SCLK	printer panel data transmission signal
9	←	b2	SCEN	Printer panel data receive enable signal
10	←	b1	OPTION1	Option board detection signal 1

TWINS board(J35) ↔ FAX-L1000 Printer kit (J2)

J35	J2	Signal name	Description	
1	—	a1	+3.3V	+3.3V
2	—	a2	DGND	Ground

TWINS board(J36) ↔ Power supply unit (J202)

J36	J202	Signal name	Description	
1	←	1	CXPON	ESS Power supply control signal
2	→	2	+12V	+12V(off while ESS)
3	—	3	12GND	Ground
4	→	4	+24V	+24V(off while ESS)

TWINS board(J36) ↔ Power supply unit (J202)

J36		J202	Signal name	Description
5	→	5	+24V	+24V(off while ESS)
6	—	6	24GND	Ground
7	—	7	24GND	Ground
8	→	8	+5V	+5V
9	→	9	+5V	+5V
10	—	10	GND	Ground
11	—	11	GND	Ground
12	→	12	+3.3V	+3.3V(off while ESS)
13	→	13	+3.3V	+3.3V(off while ESS)
14	—	14	GND	Ground
15	—	15	GND	Ground

TWINS board (J37) ↔ ISDN G4 board (J2) (FAX-L1000 ISDN KIT)

J37		J701	Signal name	Description
1	—	14	GND	Ground
2	→	13	+5V	Logic drive voltage
3	→	12	+5V	Logic drive voltage
4	→	11	+5V	Logic drive voltage
5	—	10	GND	Ground
6	—	9	GND	Ground
7	→	8	+3.3V	Logic drive voltage
8	—	7	GND	Ground
9	→	6	+3.3V	Logic drive voltage
10	→	5	+3.3V	Logic drive voltage
11	—	4	GND	Ground
12	—	3	GND	Ground
13	→	2	+12V	Logic drive voltage
14	—	1	GND	Ground

TWINS board (J39) ↔ ISDN G4 board (J1) (FAX-L1000 ISDN KIT)

J39		J700	Signal name	Description
A1	—	A20	N.C	Not connected
A2	→	A19	SPKON	Speaker on signal
A3	—	A18	GND	Ground
A4	←	A17	OPTION2	Option board detection signal 2
A5	←	A16	OPTION1	Option board detection signal 1
A6	←	A15	OPTION0	Option board detection signal 0
A7	→	A14	RESET	Reset signal
A8	←	A13	SELECT	Select signal
A9	←	A12	PERROR	Print error signal
A10	←	A11	BUSY	Busy signal
A11	→	A10	nACK	ACK signal
A12	—	A9	PD7	Data signal

TWINS board (J39) ↔ ISDN G4 board (J1) (FAX-L1000 ISDN KIT)

J39		J700	Signal name	Description
A13	—	A8	PD6	Data signal
A14	—	A7	PD5	Data signal
A15	—	A6	PD4	Data signal
A16	—	A5	PD3	Data signal
A17	—	A4	PD2	Data signal
A18	—	A3	PD1	Data signal
A19	—	A2	PD0	Data signal
A20	→	A1	nSTROBE	Strobe signal
B1	→	B20	nAUTOFD	Auto feed signal
B2	←	B19	nFAULT	Fault signal
B3	→	B18	nINIT	Initialize signal
B4	→	B17	nSELECTIN	Select in signal
B5	—	B16	GND	Ground
B6	—	B15	GND	Ground
B7	—	B14	GND	Ground
B8	—	B13	GND	Ground
B9	—	B12	N.C	Not connected
B10	—	B11	N.C	Not connected
B11	—	B10	N.C	Not connected
B12	—	B9	N.C	Not connected
B13	←	B8	N.C	Not connected
B14	←	B7	N.C	Not connected
B15	—	B6	GND	Ground
B16	—	B5	PSPOUT	Speaker signal
B17	←	B4	N.C	Not connected
B18	→	B3	N.C	Not connected
B19	←	B2	CICNT	CICNT
B20	—	B1	N.C	Not connected

TWINS board (J43) ↔ ISDN G4 board (J3) (FAX-L1000 ISDN KIT)

J43		J3	Signal name	Description
1	—	8	N.C	Not connected
2	—	7	N.C	Not connected
3	→	6	24V	FAX-L1000 ISDN KIT drive voltage
4	—	5	GND	Ground
7	→	2	12V	Logic drive voltage
8	—	1	GND	Ground

TWINS board (J43) ↔ G4 Relay board (J1) (FAX-L1000 ISDN KIT)

J43		J1	Signal name	Description
1	→	1	5V	Logic drive voltage
6	—	2	GND	ground

Chapter 5

Appendix

1. INSTALLATION

Here is the procedure for installing this fax.

Contents

1.1 Setting up the Fax

- Where to set up the fax
- Space around the fax
- Power requirements

1.2 Unpacking

1.3 Removing the Shipping Material

1.4 Assembling the Fax

- Installing the toner cartridge
- Attaching trays
- Installing paper feed unit (PF-52)
- Loading paper in paper cassettes 1 and 2
- Connecting the handset (option)
- Connecting the telephone line
- Connecting an extension phone
- Using the MP tray
- Turning on the power
- Processing when trouble occurs

1.5 Checking Operations

- Copy operation
- Communication test

1.6 Moving the Fax Unit



NOTE

This installation section is the same as in the USER'S GUIDE so its layout differs from other pages.

1.1 Setting up the Fax



Caution

CAUTIONS SHOW YOU HOW TO AVOID CONDITIONS OR INCORRECT OPERATIONS THAT COULD CAUSE DAMAGE TO YOUR HARDWARE OR SOFTWARE OR CAUSE PERSONAL INJURY.



This icon denotes feeding a document.

Where to Set Up the Fax

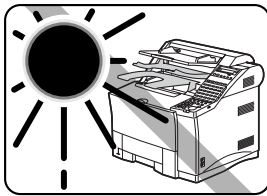

- Avoid direct sunlight. If you have to place the fax near a window, install heavy curtains or blinds to protect the fax from direct sunlight.

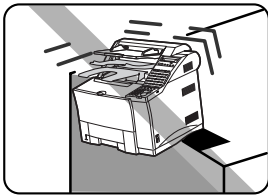

- Choose a flat, stable surface free of vibration.

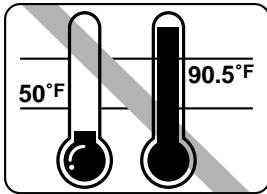

- Avoid a location subject to extreme temperature fluctuation. Use in a location within a temperature range of 50°F to 90.5°F (10°C to 32.5°C).

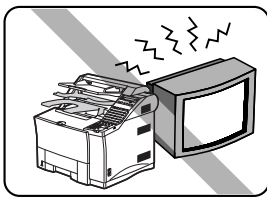

- Do not set up the fax near a television, radio, or heavy equipment like copy machines, air conditioners, computers, or large printers that can generate strong electromagnetic fields. Large equipment can generate electronic noise that can interfere with the operation of the fax.

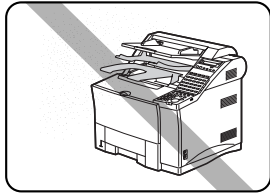

- Choose a location that is clean and free from dust and moisture.

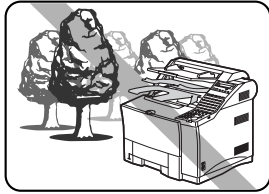

- Do not use or store the fax outdoors.

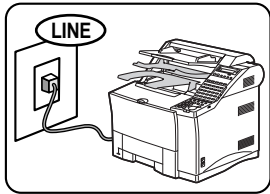

- Place the fax unit near a telephone line. You must have an RJ11-C wall jack installed. If you need assistance, contact your authorized Canon dealer or service representative, or your local telephone company.

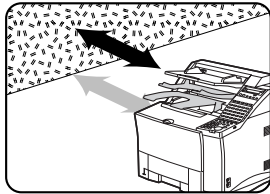

- To avoid damage to the fax unit from overheating, do not block the exhaust vent. Install the fax unit approximately 4 in. (10 cm) away from walls or other equipment.

Space Around the Fax

To ensure proper ventilation and easy operation, set up the fax in an area that meets the minimum requirements for clearance as illustrated below.



TO AVOID DAMAGE TO THE FAX UNIT FROM OVERHEATING, DO NOT BLOCK THE EXHAUST VENT. INSTALL THE FAX UNIT APPROXIMATELY 10 CM AWAY FROM WALLS OR OTHER EQUIPMENT.

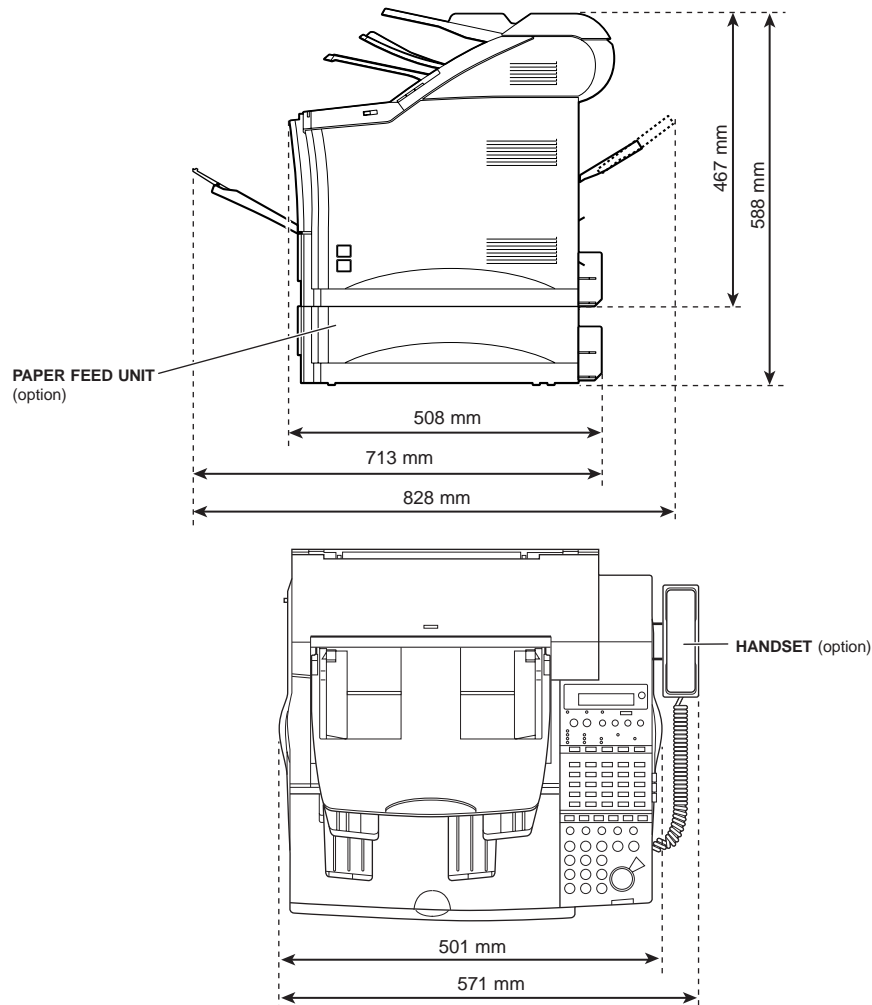

Power Requirements

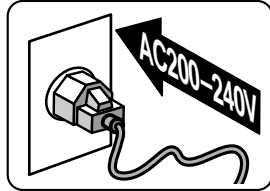

- ❑ Place the fax near a standard 200 – 240 V AC power outlet. This fax unit is intended for domestic use. Do not attempt to use it outside the country where you purchased it.

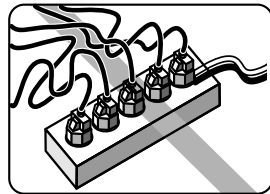

- ❑ Do not plug the power cord into an extension cord connector or power strip shared with other plugs.

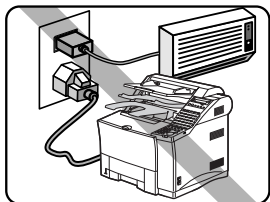

- ❑ Do not plug the fax into a power outlet shared with an air conditioner, personal computer, electric typewriter, copier, or other equipment that generates electrical noise.

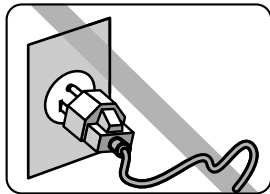

- ❑ Check the plug frequently and make sure that it is firmly plugged into the socket.
- ❑ Do not plug the power cord into an uninterruptable power supply (UPS).

1.2 Unpacking

Unpacking: Have You Got Everything?

As you unpack the fax, save the carton and packing material in case you want to move or ship the fax unit in the future. Ask someone to help you remove all items from the box.



Caution

LIFTING THE FAX UNIT REQUIRES TWO PEOPLE. TO REMOVE THE FAX UNIT FROM THE CARTON BOX, FOLLOW THE GENERAL GUIDELINES AND ILLUSTRATION ON THIS CHAPTER, 1.6 Moving the Fax Unit.

1. Remove the adhesive tapes on the top of the carton box.
2. Take out the document feeder tray, the accessory tray with the document output tray, the accessory tray with the document output tray, documentation, the upper output tray, power cord and telephone line, and the FX6 Toner Cartridge in its protective bag.

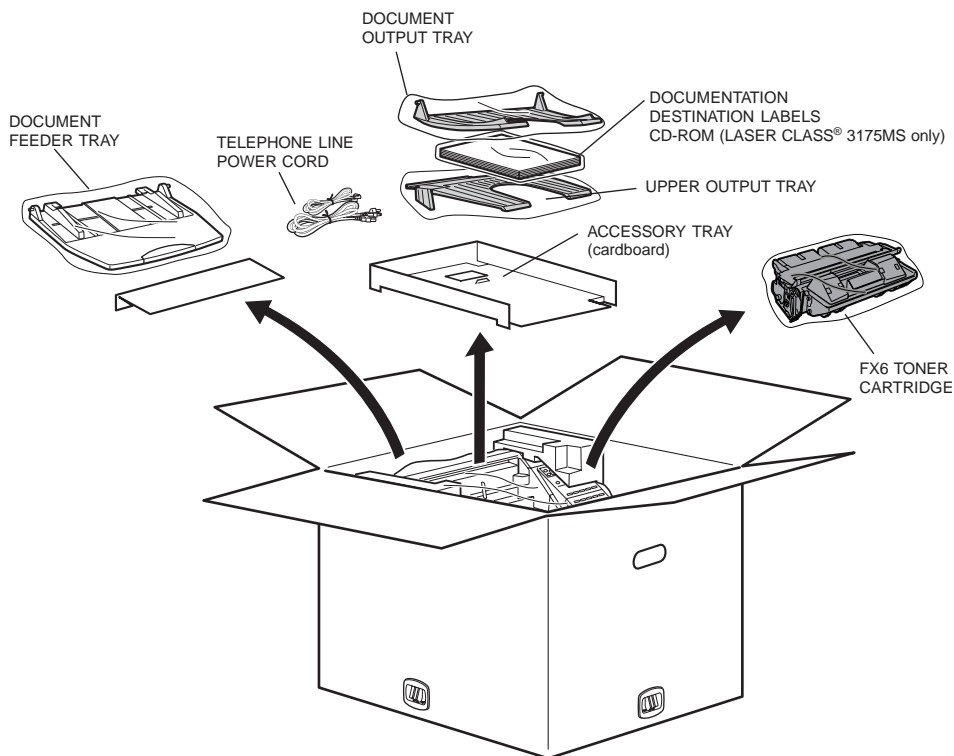

3. Remove the four stoppers on the side of the box by squeezing the center grip.

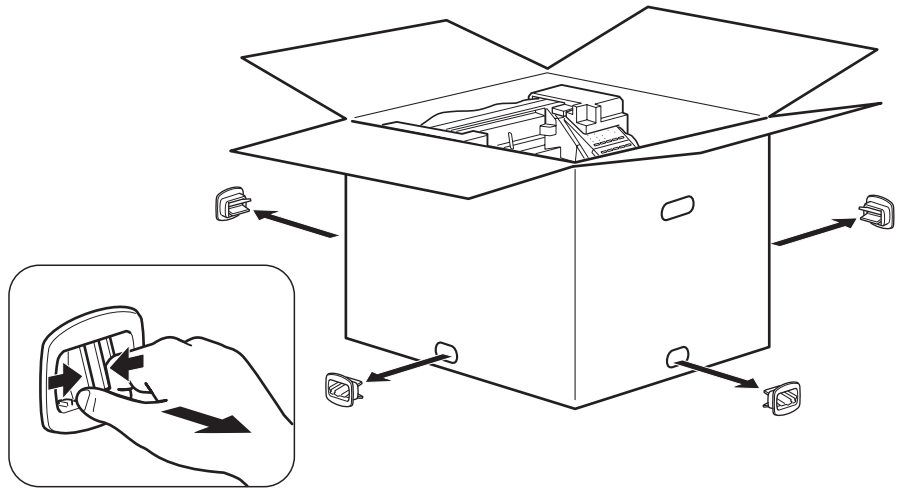

4. Lift and remove the upper carton. Remove the four styrene foam blocks positioned on top of the fax unit. Then lift the fax unit by gripping the handles on the right and left sides.

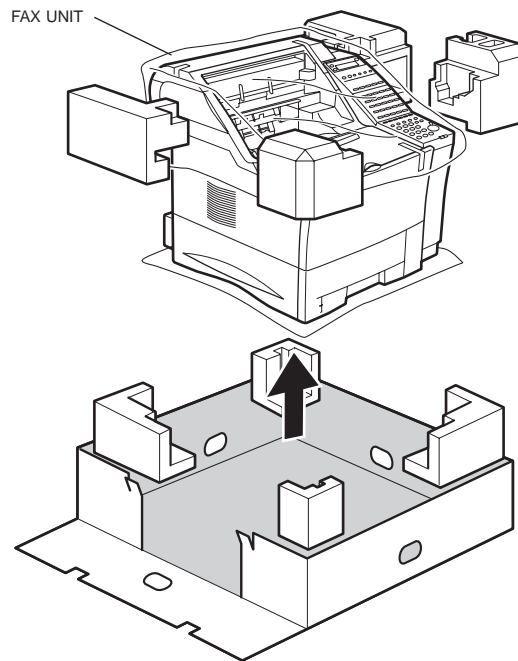

Check each item against this list as you remove it from the box.

- 1 Fax machine
- 1 Document feeder tray
- 1 Document output tray
- 1 Upper output tray
- 1 Paper Cassette 1 (letter-, legal-, A4-size, 500-sheet capacity)
- 1 Power cord
- 1 Telephone line
- 2 Sheets of destination labels
- 1 Sheet of tray labels
- 1 Facsimile User's Guide
- 1 M label (U.K. only)
- 1 FX6 Toner Cartridge

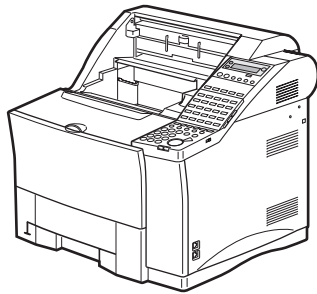

FAX UNIT
(with Paper Cassette 1 installed)

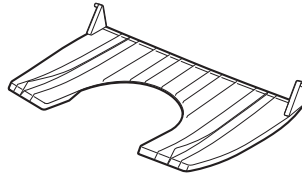

**DOCUMENT
OUTPUT TRAY**

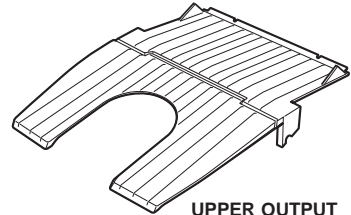

**UPPER OUTPUT
TRAY**

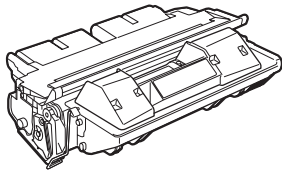

FX6 TONER CARTRIDGE

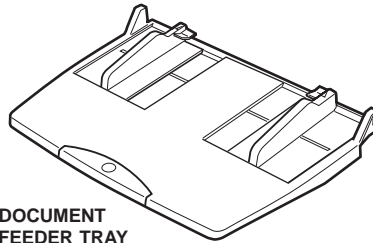

**DOCUMENT
FEEDER TRAY**

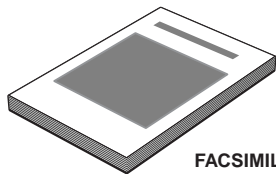

**FACSIMILE
USER'S GUIDE**

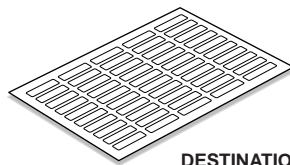

**DESTINATION
LABELS × 2**

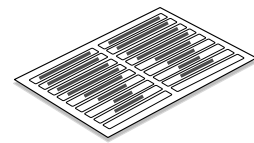

**TRAY
LABELS × 1**

TELEPHONE LINE

POWER CORD

1.3 Removing the Shipping Material

Removing the Shipping Material

All shipping materials must be removed. Shipping materials are attached inside the fax unit and inside the paper cassette to protect delicate parts from vibration during shipping.

Removing the Shipping Tapes

Remove all the shipping tapes from the unit.

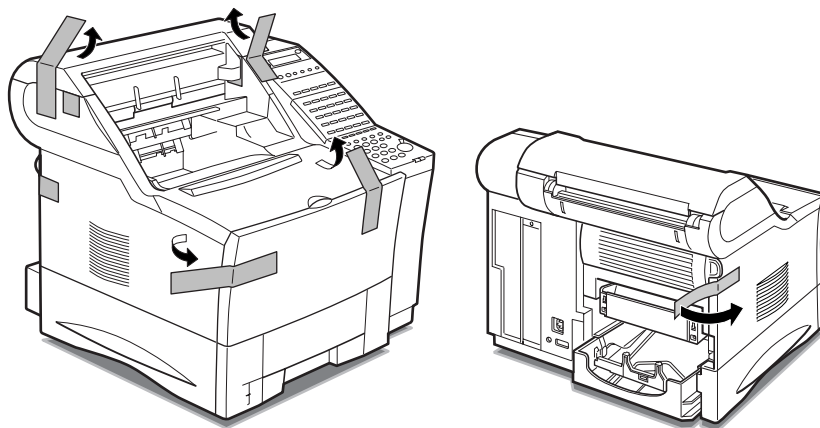

Removing the Packing Materials Inside the Fax Unit

1. Gently lift the ADF cover and remove the styrene foam sheet from inside the feeder area.

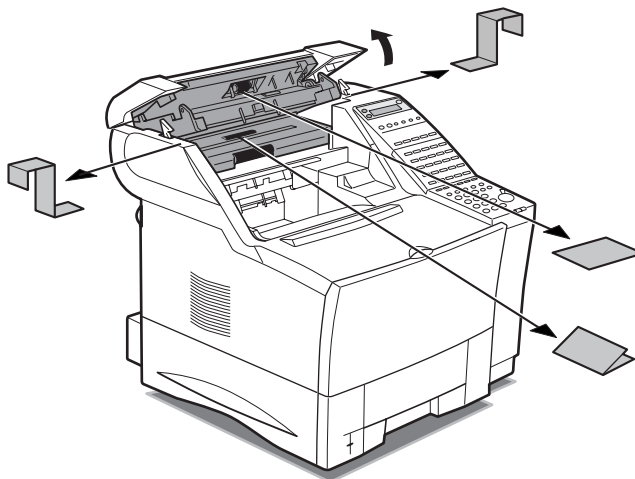

2. Close the ADF cover.
3. Open the printer cover and the MP tray.

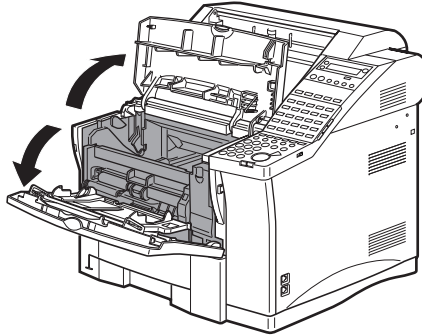

4. Remove the tapes and packing materials.

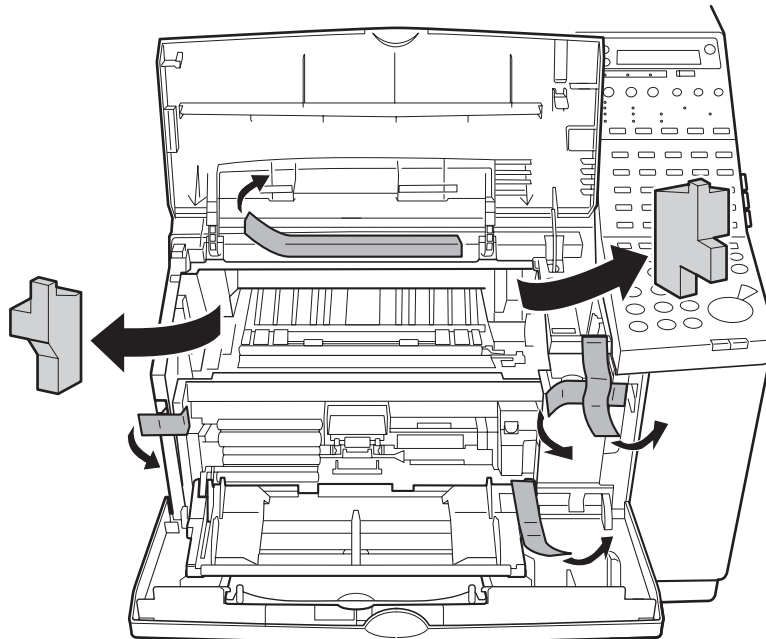

5. Close the printer cover and the MP tray.



- Save all the packing materials. You may want to insert them again if you have to transport the fax unit.
- When removing the packing materials from inside the printer area, be careful not to touch the transfer charging roller. Otherwise, the print quality may deteriorate.

Removing the Packing Materials from Paper Cassette 1

1. Pull out the Paper Cassette 1 and remove it from the fax unit.

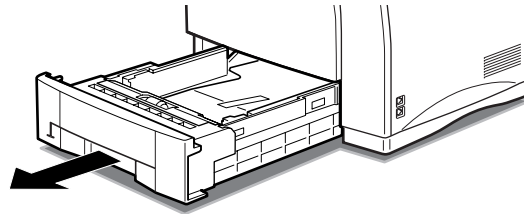

2. Set Paper Cassette 1 down on a flat, stable surface.
3. If tapes are attached to the paper cassette, remove them. Then remove the white spacers under the paper guide clips by first pressing down on the bottom metal plate with one hand and then sliding the white spacers inwards with the other hand.

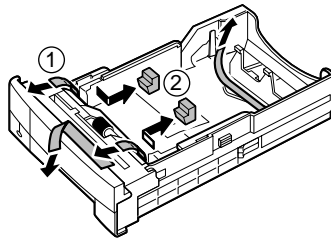

4. Insert Paper Cassette 1 in the fax unit.

Removing the Protective Plastic Sheet

The LCD on the operation panel is covered with a plastic sheet to protect it during shipping. This protective material should be removed before you use the fax unit.

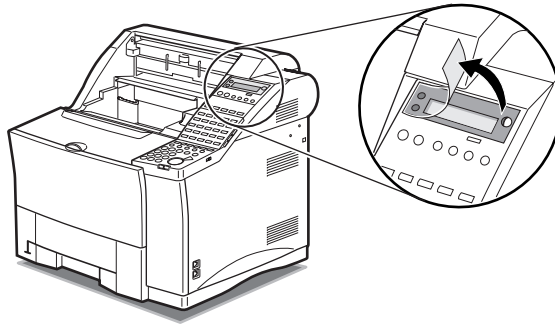

1.4 Assembling the Fax

Assembling the Fax

Follow the instructions in this section to assemble the fax and prepare it for full operation.

Installing the Toner Cartridge

Install only a Canon FX6 Toner Cartridge in your fax machine.



INSTALLING ANY OTHER TYPE OF CARTRIDGE IN THIS FAX UNIT COULD DAMAGE THE FAX UNIT AND VOID YOUR WARRANTY. LEAVE THE TONER CARTRIDGE IN ITS PROTECTIVE BAG UNTIL YOU ARE READY TO INSTALL THE CARTRIDGE. HANDLE THE TONER CARTRIDGE CAREFULLY.

1. Open the printer cover.

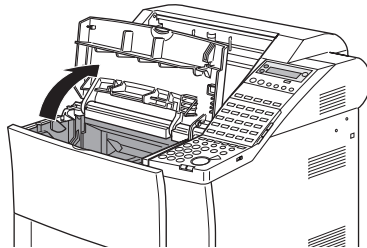

2. Remove the toner cartridge from its protective bag.

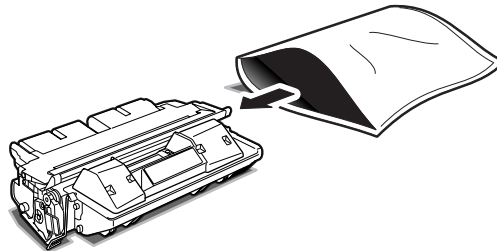

Save the protective bag. You can use it later to cover the cartridge if you have to remove it from the fax machine.



Note

Save the protective bag and all other shipping material. You will need this material later when you dispose of the cartridge after it has run out of toner.

3. Hold the cartridge by the ends and rock it gently five or six times to distribute the toner evenly inside the cartridge.

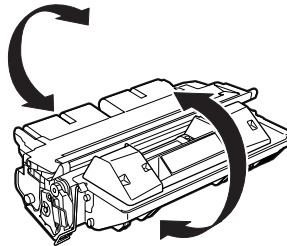

4. Place the new cartridge on a stable, flat, clean surface, and snap the tab to detach it from the cartridge.

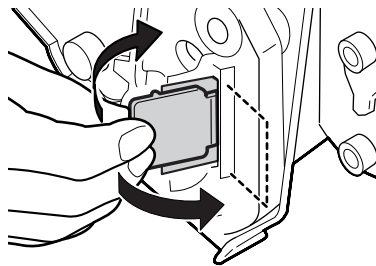

5. As you steady the cartridge with one hand, remove the seal by gently pulling the plastic tab with your other hand. Use a firm, even pull to avoid breaking the seal.

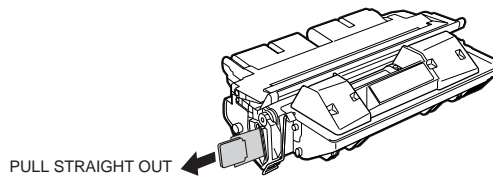

Note

- Do not pull the tab upwards or downwards; the tape may break.
- If the tab breaks off from the tape, pull the tape out by pulling on the end of the tape where the tab was originally attached.
- Wash off any toner from your hands or clothing immediately with cold water.

6. To avoid pinching your fingers between the toner cartridge and fax unit, grip the cartridge as shown below.

KEEP THE DRUM SLOT FREE OF DUST AND OTHER FOREIGN OBJECTS.

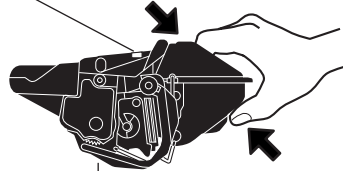

DO NOT TOUCH THE PROTECTIVE SHUTTER ON THE BOTTOM OF CARTRIDGE.

7. Load the cartridge in the direction indicated by the arrow. Gently slide the cartridge into the printer area until it is down inside the fax unit and level.

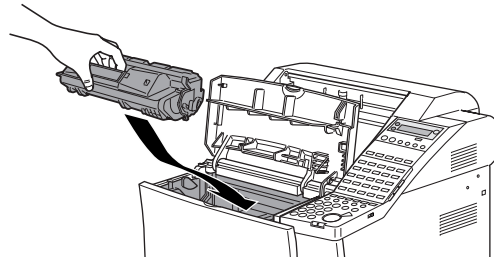

8. Shut the printer cover.

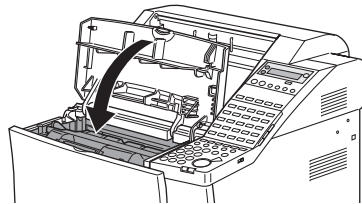

- The fax unit will not operate if the printer cover is not closed completely.

CHECK PRINTER COVER

If you see the message above and the Error lamp blinks red when the fax unit is plugged in, open the cover again and make sure the toner cartridge is level. Then shut the printer cover again.

Attaching the Document Output Tray and the Upper Output Tray

1. Attach the upper output tray to the front of the fax unit. Slide the end of the upper output tray down into the fax unit at an incline, lifting the end nearest you.

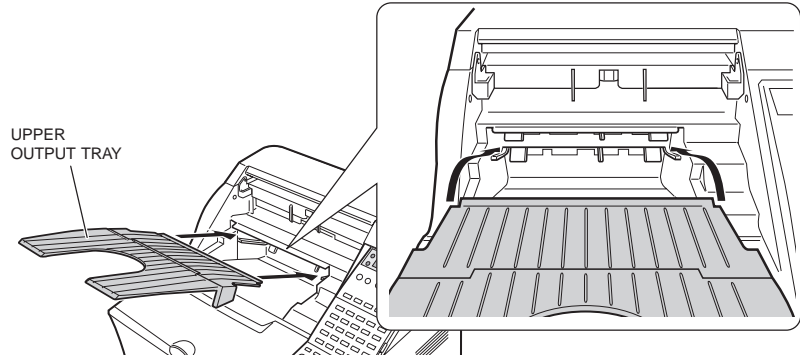

Note

- Do not use the fax without first attaching the upper output tray correctly. A paper jam may occur.
- When removing the upper output tray, lift the end nearest you slightly and pull the tray forward.

2. Attach the document output tray to the front of the fax unit, just above the upper output tray.

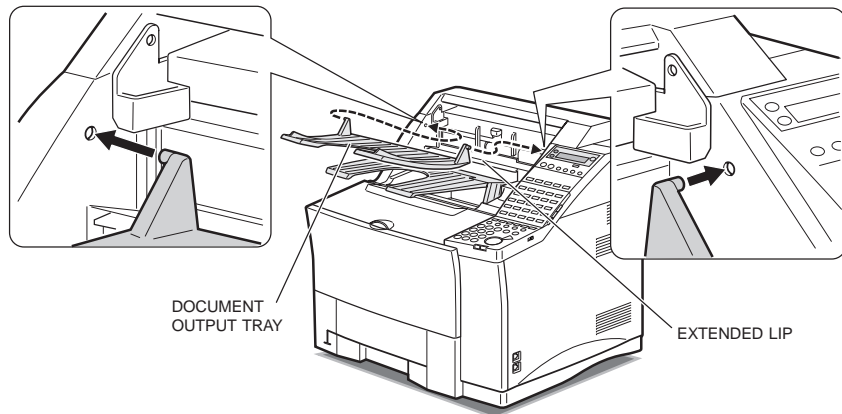



Note

Make sure the knobs on each side of the tray fit into the holes on the side of the fax unit. Back of the tray sits on top of the extended lip of the fax unit.

Attaching the Document Feeder Tray

Slide one side in position first and then the other side.

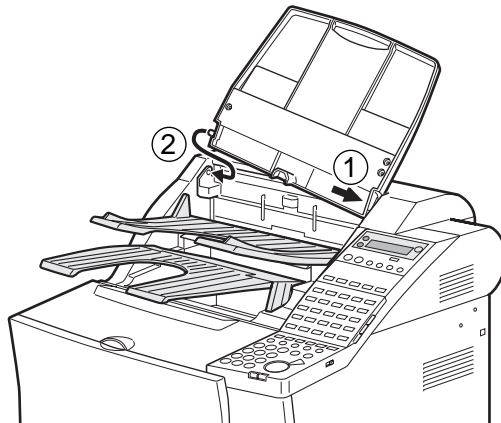

- ❑ Attach the supplied tray labels as shown in the illustration below. We also recommend attaching the tray labels onto the upper and lower output trays according to the settings you make on the SELECT OUTPUT TRAY menu to classify the outputs. You can use the blank labels to meet your specific needs.

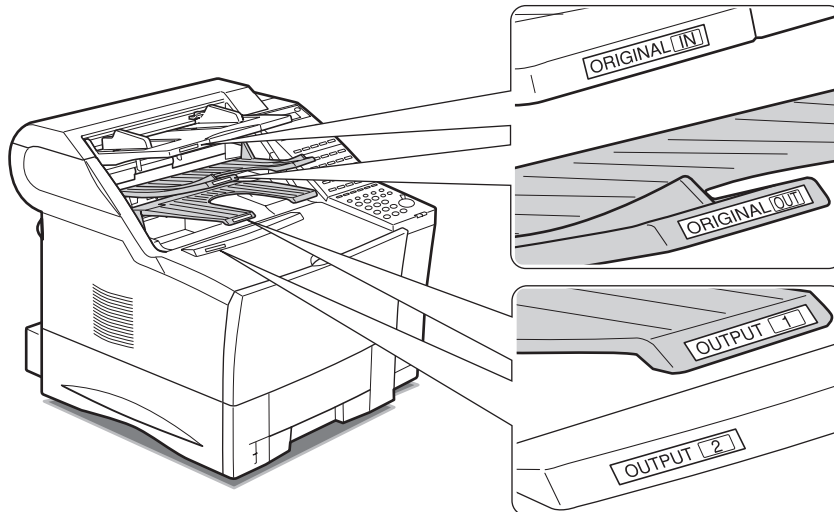

Installing Paper Feed Unit (PF-52) (option)

1. Take out Paper Feed Unit (PF-52) from its carton box.

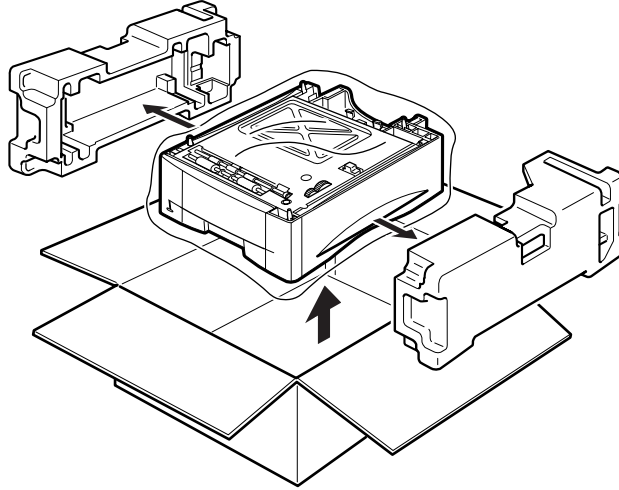

2. Remove the tape at the front of Paper Feed Unit (PF-52).

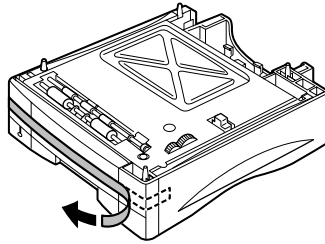

3. Pull out the paper cassette.

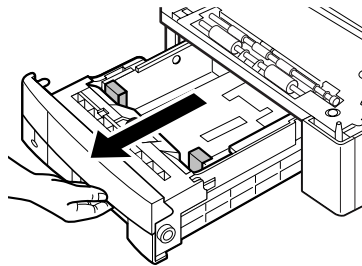

4. If tapes are attached to the paper cassette, remove them. Then remove the spacers under the paper guide clips by first pressing down on the bottom metal plate with one hand and then sliding the white spacers inwards with the other hand.

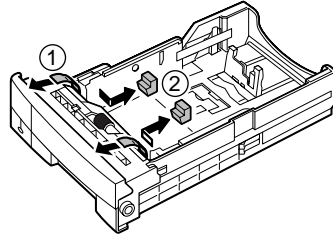

5. Remove the tapes and packings at the rear of the paper cassette.

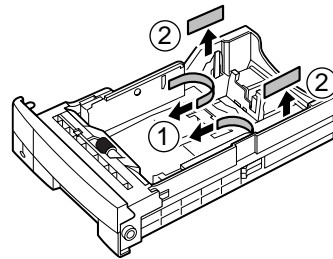

6. If a spacer is attached, remove it from the paper cassette while pressing the bottom plate.

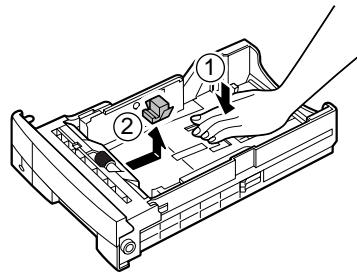

7. Replace the cassette into Paper Feed Unit (PF-52) and place it in the location you wish to use the fax after the cassette has been installed.

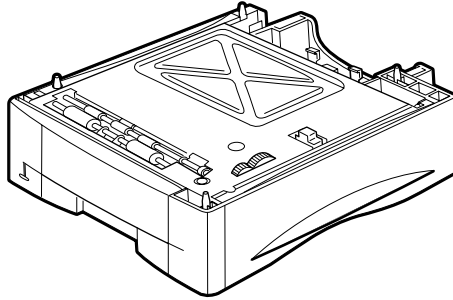

Note

You will need to move the fax unit if you want to use it in the same location it now occupies.

8. Lift up the fax unit and hold it over Paper Feed Unit (PF-52).



Caution

LIFTING THE FAX UNIT REQUIRES TWO PEOPLE. TO MOUNT THE FAX UNIT ONTO PAPER FEED UNIT (PF-52), FOLLOW THE GENERAL GUIDELINES AND ILLUSTRATION ON THIS CHAPTER, 1.6 Moving The Fax Unit.

ALWAYS LIFT THE FAX UNIT BY THE LIFTING HANDLES AT THE BOTTOM, TO AVOID TRAPPING YOUR FINGERS BETWEEN THE FAX UNIT AND PAPER FEED UNIT (PF-52).

WHENEVER YOU MOVE THE FAX, BE SURE TO LIFT THE FAX UNIT AND PAPER FEED UNIT (PF-52) SEPARATELY. DO NOT TRY TO LIFT THEM TOGETHER.



Note

If the fax unit is heavy to lift, remove Paper Cassette 1 and toner cartridge before placing it on Paper Feed Unit (PF-52).

9. Make sure the front of the fax unit is facing the same direction as the front of Paper Feed Unit (PF-52). Slowly lower the fax unit onto the four positioning poles on the corners of Paper Feed Unit (PF-52).

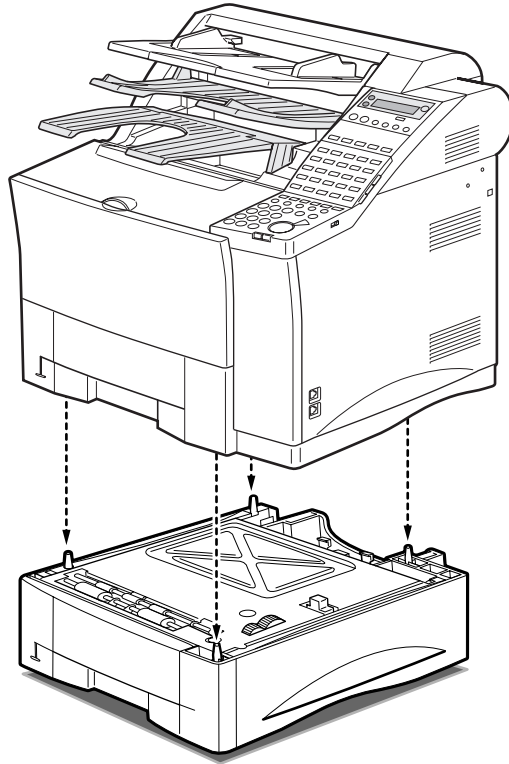

Loading Paper in Paper Cassettes 1 and 2

Before you load paper, follow these general guidelines:

- ❑ The paper cassettes can be adjusted to hold various sizes of paper. Paper Cassette 1 holds letter-, legal- or A4-size paper, and Paper Cassette 2 holds letter-, legal-, A4-, executive- or B5-size paper.



Note

You can load executive- or B5-size paper in Paper Cassette 2 only when you use it for the printer function. When you use it as a paper supply for fax, you can load letter-, legal- or A4-size paper only.

- ❑ For high-quality printings, we recommend using Canon standard 17-24 lb. (64-90g/m²) weight paper.
- ❑ Use of print media not meeting the paper's requirements may cause severe paper jams or result in excessive mechanical wear of the fax.
- ❑ Do not use the following paper in the paper cassettes:
 - Moist paper
 - Paper that is wavy, curled or damaged
 - Folded, clipped or stapled paper
 - Paper containing materials that melt, vaporize, offset, discolor or emit dangerous fumes at a temperature of 374°F (190°C) or higher
- ❑ To avoid paper curling, do not open paper packs until you are ready to load the paper in the fax unit. Store unused paper from opened packs in a cool, dry location.
- ❑ Let the paper run out before you refill the paper cassettes. Avoid mixing new paper with paper remaining in the paper cassettes.



Note

- Do not load different sizes of paper in the paper cassettes at the same time.
- If a printed page comes out of the fax all curled up, you can correct the problem by turning over the paper stack in the paper cassettes so that the bottom sheet in the stack is now at the top.
- If the leading edge of the paper is curled, straighten it out as much as possible before loading it into the paper cassettes.
- Do not set the paper-size guides so tight that the paper stack bends.
- Do not set the paper-size guides so loose that the paper stack is not evenly aligned.
- Do not set the paper-size guides so loose that there is room between the guides and the paper.

1. Pull out the paper cassettes from the fax unit.

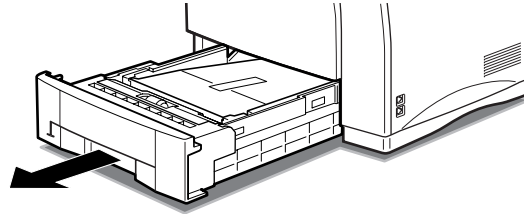

2. Check if the selectors inside the paper cassettes are set for the size of the paper you are loading.

If the setting is correct, go on to step 3.

-if not-

Set the paper cassettes to fit the sizes of the paper you are loading.

To change the paper size for Paper Cassette 1

Adjust the paper size side guides in the following way:

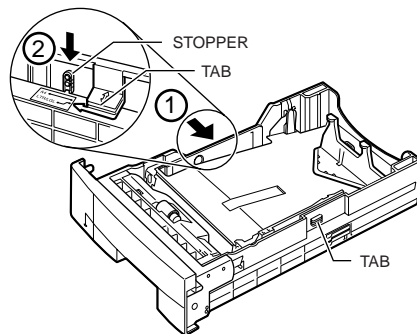

WHEN YOU SET TO A4 SIZE.

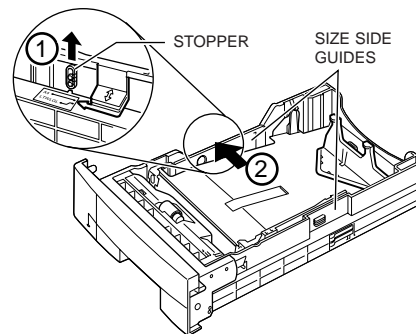

WHEN YOU SET TO LETTER OR LEGAL SIZE.

- To select A4 size, push the tabs jutting out from the edge of the cassette inwards and slide the stopper downwards to lock the guides in position.
- To select letter and legal size, slide the stopper up and push the size side guides outwards.

Lift the stopper in the center of the paper size rear guide slightly, and slide it to the mark indicating the desired paper size.

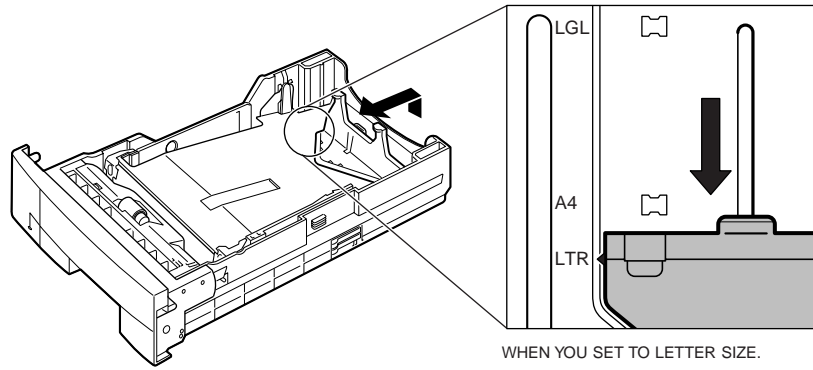

To change the paper size for Paper Cassette 2 (option)

To adjust the paper size side guides, release them by pinching the stopper on the left guide and slide them inwards or outwards according to the paper size you are loading.

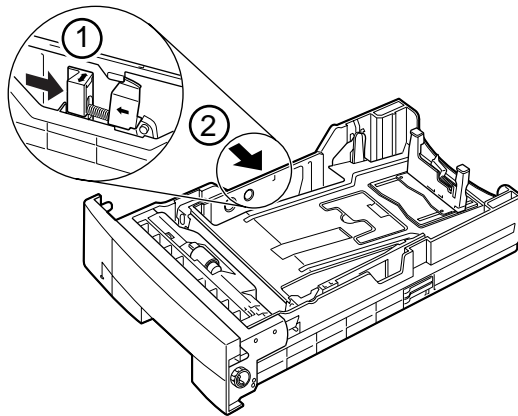

Push up the stopper of the paper size rear guide, and slide it to the mark indicating the desired paper size.

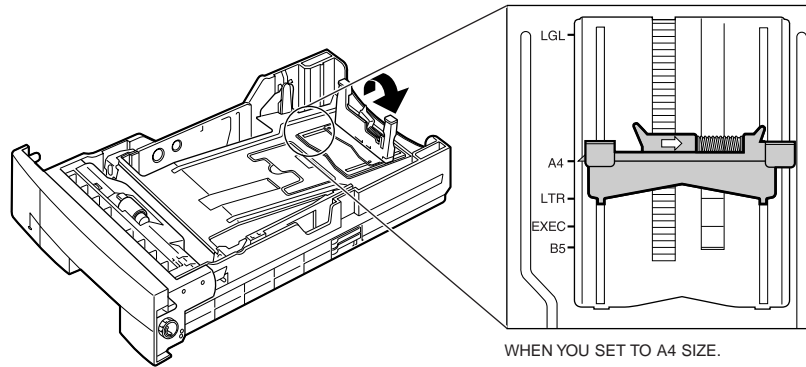

Note

You can load executive- or B5-size paper in Paper Cassette 2 only when you use it for the printer function. When you use it as a paper supply for fax, you can load letter-, legal- or A4-size paper only.

Turn the dial on the right-front side of the cassette and adjust it to the size of paper you are loading.

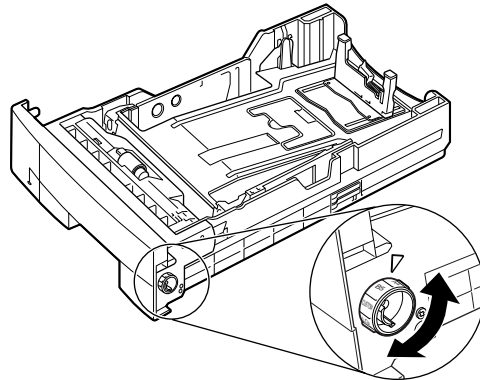

Note

- Make sure the mark on the paper size setting dial corresponds with the size of the installed paper, otherwise a paper jam may occur.
- Do not set the paper size dial on this unit to CUSTOM. This setting is not supported by this fax.

3. Before you load a stack of paper into the paper cassettes, tap the leading edge of the paper stack on a flat surface so that the edges are evenly aligned.

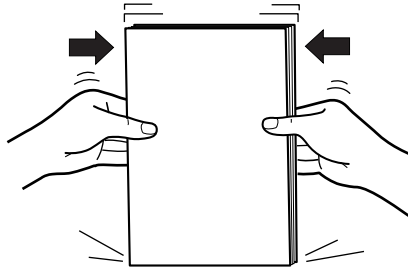

4. Place the stack of paper in the paper cassettes with the print side facing down. Insert the stack of paper so that it fits neatly to the back of the paper cassettes.

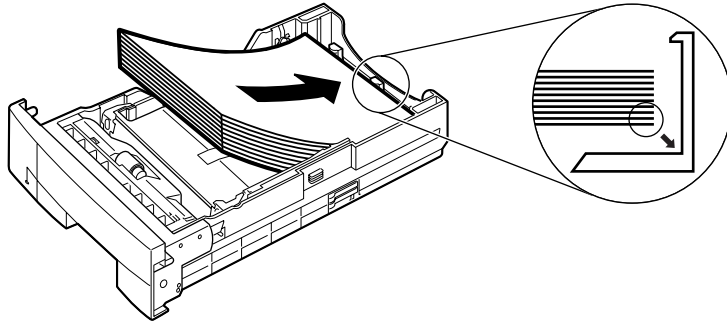

Note

When loading 500 sheets into the paper cassettes, divide the stack in two evenly-sized stacks, then load each stack separately.

5. Press down on the front of the paper stack to make sure the corners are below the paper size guide clips. Then press the stack down again to make sure it is below the paper limit marks on the side of the paper cassettes and the paper size guides hook at the back of the cassettes.

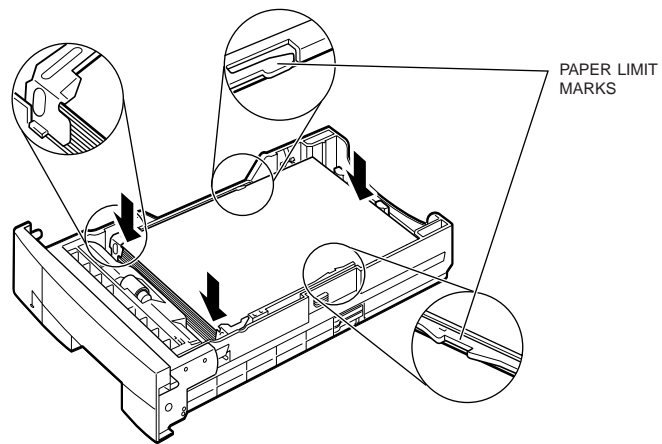

6. Press the paper stack down to make sure it has a clearance of approximately 0.04 in. (1 mm) from the hook of the paper size rear guide.

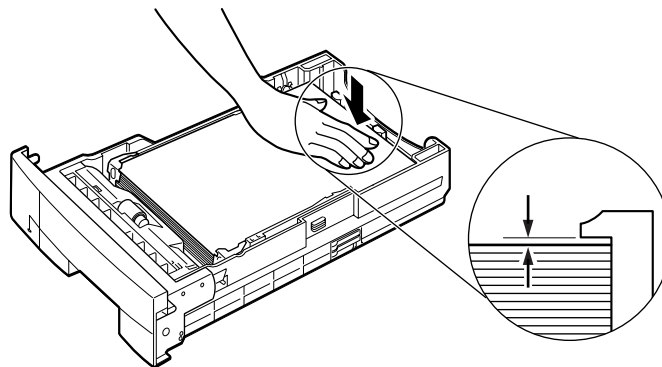

7. Reinsert the cassette into the fax unit: Align the cassette with the rails on the fax unit, then lift slightly to insert the cassette. Slide it all the way into the fax unit.

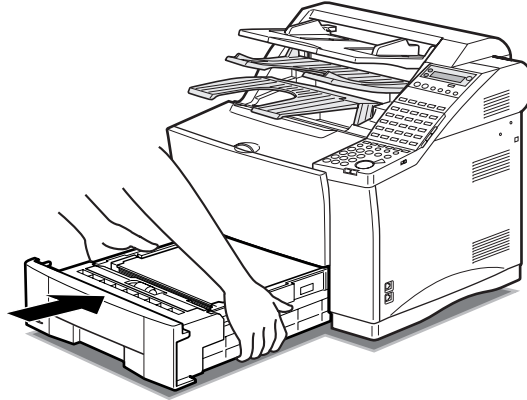

Note

Make sure you insert the cassette all the way into the fax unit until it locks into place.

- The paper volume status bars on the paper cassettes indicate the level of the current paper supply. When you see the paper volume status bar drop, make sure you have a supply of paper on hand to fill the cassettes. When you see the SUPPLY REC. PAPER message on the LCD display, re-fill the cassettes.

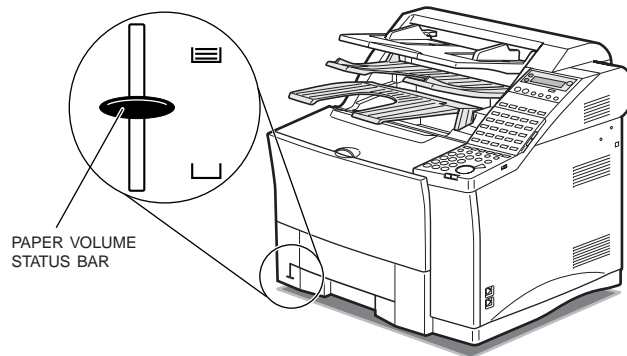

Connecting an Extension Phone

To connect an extension phone to the fax, you have to use the extension phone jack.



Only one jack is provided to be used with the optional handset or an extension phone. A separate jack is not provided for an extension phone.

Connect the extension phone cord to the extension phone jack marked with the handset icon ().

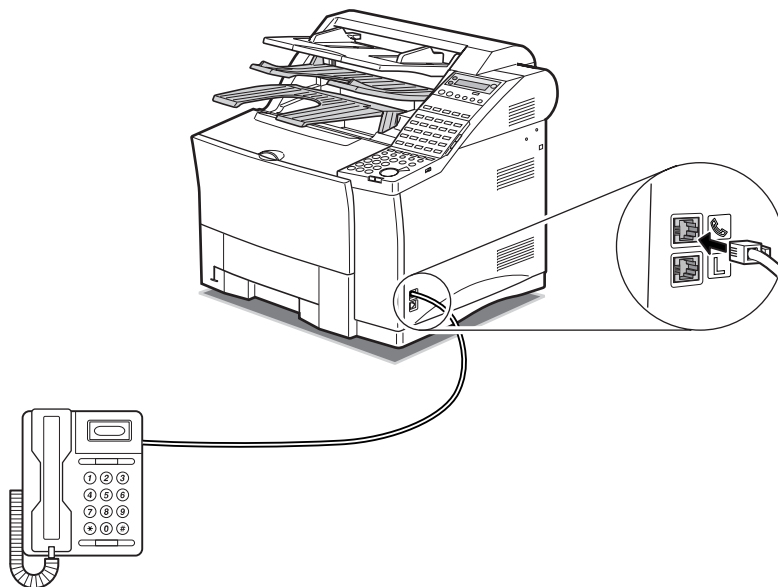

- ❑ Users in the U.K. only
When connecting an extension phone, be sure to connect the B.T. adapter. Contact your Canon Supplier for more information.
B.T. adapter is available as an option.

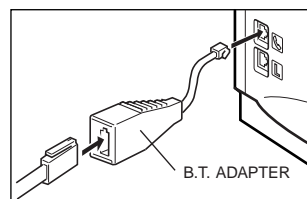

U.K. ONLY

Using the MP Tray

The MP (multi-purpose) tray can hold letter-, legal- or A4-size paper. The capacity is approximately 100 sheets of cut-sheet paper (80 g/m²). To use the MP tray as one of the input trays, you need to set USE MP TRAY to ON in the FAX'S PRINTER SET menu.

To use the MP tray after installation of the FAX-L1000 Printer Kit, follow the guidelines below. Otherwise, the paper-size-matching error occurs and the message "CHECK PAPER SIZE" appears on the display.

- Even when you use the MP tray for the fax function, it is necessary to set the same paper size on the printer menus as on the fax menus. For details about setting the paper size of the MP tray on the printer menus, refer to "Printing from the Multi-Purpose Tray" in the Printer User's Guide supplied with the optional FAX-L1000 Printer Kit.
- If you use the MP tray for the printer function and load paper of sizes other than letter, legal or A4, it is necessary to set USE MP TRAY to OFF on the FAX'S PRINTER SET menu.



Note

The sizes and kinds of print media you can set on the MP tray differ when you use it as an input tray for the printer function. For details on the print media specifications for the printer function, refer to the "Print Media Specifications" section in Appendix D of the Printer User's Guide.

When not in use, the tray can fold up into the fax unit.

Loading the MP Tray

Before you load the paper, follow these general guidelines:

- For high-quality printings, we recommend using Canon standard 64-90g/m² weight paper.
- Use of print media not meeting the paper's requirements may cause severe paper jams or result in excessive mechanical wear of the fax.
- Do not use the following paper in the MP tray:
 - Moist paper
 - Paper that is wavy, curled or damaged
 - Folded, clipped or stapled paper
 - Paper with cut-outs or perforations (not recommended)
 - Paper containing materials that melt, vaporize, offset, discolor or emit dangerous fumes at a temperature of 190°C or higher



- Avoid pressing or applying excessive force on the MP tray as this may cause damage.
- The paper stack must not exceed the paper limit mark.
- Do not load different sizes of paper on the MP tray at the same time.
- Do not add paper to the MP tray if paper is already loaded; incorrect paper feed or a paper jam may occur. Only add paper when the MP tray is empty.
- If a printed page comes out of the fax all curled up, you can correct the problem by turning over the paper stack in the MP tray so that the bottom sheet in the stack is now at the top.
- If the leading edge of the paper is curled, straighten it out as much as possible before loading it into the tray.
- Do not set the paper guides so tight that the paper stack bends.

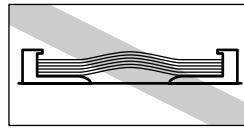

- Do not set the paper guides so loose that the paper stack is not evenly aligned.

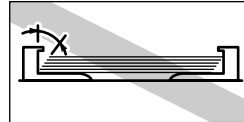

- Do not set the paper guides so loose that there is room between the guides and the paper.

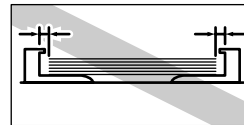

- Do not place the paper into the tray at an angle.

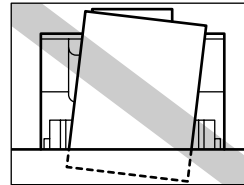

- Do not load fanned out paper. Make sure the edges of the paper stack are evenly aligned when loading.

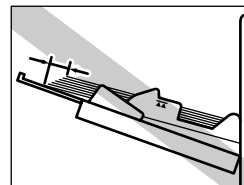

1. Pull the MP tray out using the handle on the panel.



2. Pull out the extension tray using the center grip.

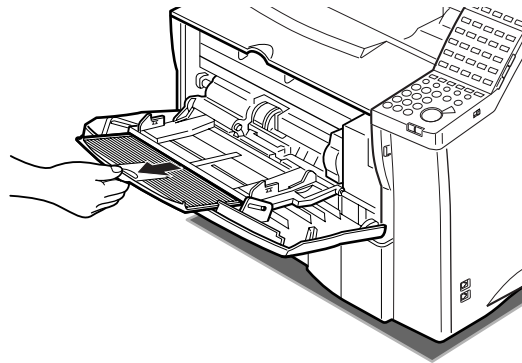

3. The MP tray holds approximately 100 sheets of paper. Before you load paper on the MP tray, tap the edges of the stack to make sure the leading edge and sides of the stack are even.

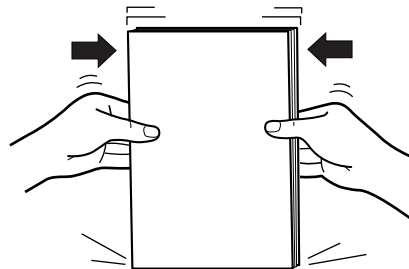

4. Insert the paper stack as far as it will go into the fax unit, with the print side facing up and the top of the paper going into the fax unit first. Then adjust the paper guides to the size of the paper.

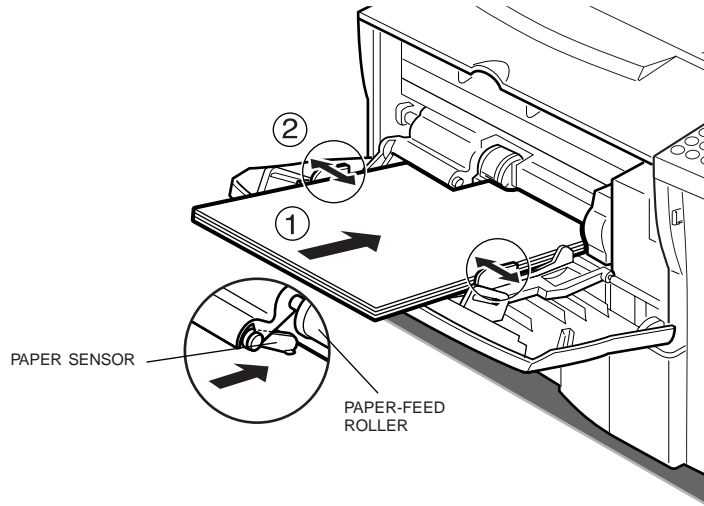

- Make sure that the leading edge of the paper is inserted all the way into the MP tray so that it is below the paper-feed roller. The paper sensor for the MP tray is located to the left of the paper feed roller, when viewed from the front of the fax unit. Please note the following points when loading small-size paper in the MP tray. (If the paper is not loaded correctly, the paper will not be detected by the fax and a message will appear asking you to load paper in the MP tray.)
- Make sure that the paper stack is not higher than the load-limit marks (▲▲) on the paper guides.

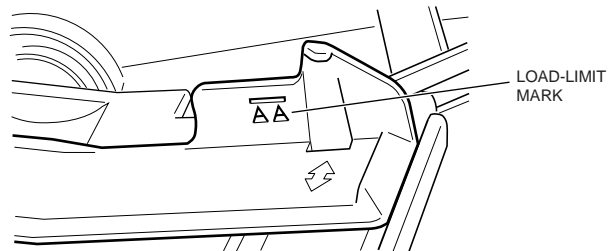



Note

- Make sure that the paper guides are set correctly. To print with the MP tray, you also need to select the paper size in the USE MP TRAY menu.
- Make sure that the paper is loaded correctly and that the leading edge is fully inserted into the fax unit.
- Make sure that the paper sensor is resting on top of the paper. (The paper sensor must rest on top of the paper, not just touch the edge of the paper.)

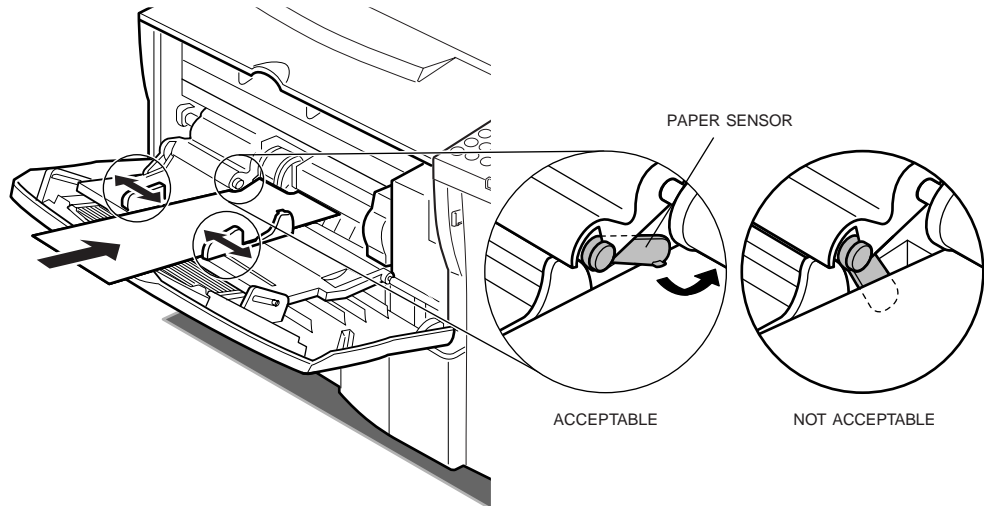

- To avoid damaging the MP tray, close it when not in use. Remove and store any remaining print media. Slide the extension tray in before closing the MP tray.

Turning on and off USE MP TRAY and Setting the Paper Size in the USE MP TRAY Menu

To use the MP tray as one of the input trays, you need to set USE MP TRAY to ON in the FAX'S PRINTER SET menu.

Also, to use the MP tray for the fax function after installation of the optional FAX-L1000 Printer Kit, it is necessary to set the same paper size on the printer menus as on the fax menus. For details about setting the paper size of the MP tray on the printer menus, refer to "Printing from the Multi-Purpose Tray" in the Printer User's Guide supplied with the optional FAX-L1000 Printer Kit.

Follow this procedure to turn on and off USE MP TRAY and to select the paper size in the fax menus.



Data
Registration

1. Open all three of the One-touch Speed Dialing panels. Then press **Data Registration**.

REGISTRATION
1. DATA REGISTRATION

Set

2. Press **Set**.

DATA REGISTRATION
1. USER SETTINGS



3. Press the search buttons until you see the display below.

DATA REGISTRATION
5. FAX'S PRINTER SET

Set

4. Press **Set**.

FAX'S PRINTER SET
1. USE MP TRAY



5. Press **Set**.



6. Press the search buttons to display ON.



Note

If you use the MP tray for the printer function and load paper of sizes other than letter, legal or A4, it is necessary to set USE MP TRAY to OFF on the FAX'S PRINTER SET menu.



7. Press **Set**.



8. Press the search buttons to select the paper size you are loading onto the MP tray.

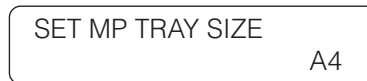

9. Press **Set**.



10. Press **Stop** to return to standby.

Turning on the Power

1. Connect the power cord to the power socket on the rear of the fax unit.
2. Connect the other end of the power cord to the power source.



THE FAX MUST BE CONNECTED TO A PROPERLY GROUNDED, THREE-PRONG 200 – 240 V AC OUTLET.

After you connect the power cord to the power source, the fax LCD display will light. There is no power switch on the fax unit.

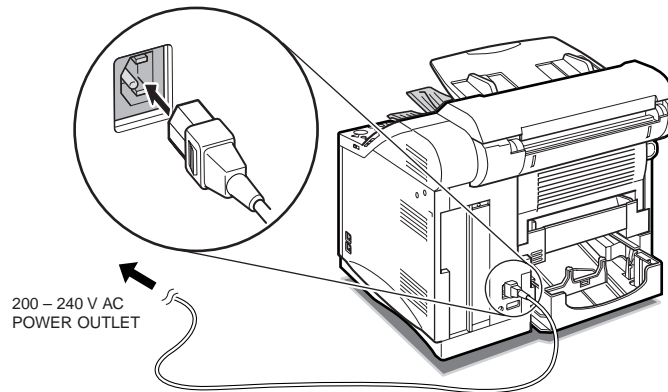

It will take a few seconds for the unit to warm up.

PLEASE WAIT

The unit has warmed up and is ready to use when you see the date and time display.

22/09 2000 FRI 12:20

When the date is displayed on the LCD, the fax is in the *standby mode* and ready for normal operation. If the Error lamp starts blinking red, wait for one of the following messages to appear.

INSTALL CARTRIDGE	You have not yet installed the toner cartridge. Install the FX6 toner cartridge.
REPLACE CARTRIDGE	The toner cartridge has run out of toner. Replace the toner cartridge.
CHECK PRINTER COVER	The printer cover is not closed completely. If it does not close easily, do not force it. Remove the toner cartridge, and insert it again. Make sure it is sitting level inside the fax machine then close the printer cover again.
SUPPLY REC. PAPER	At least one of the paper cassettes is empty or not seated correctly inside the fax machine. Remove each cassette. Make sure the stacks of paper are below the tabs and insert the paper cassettes in again. Push the paper cassettes all the way in until they lock in place.

- ❑ When ENERGY SAVER is ON, the fax switches to the energy saver mode in a specified length of time. The Energy Saver indicator lights red and ENERGY SAVER appears in the LCD display.

ENERGY SAVER



To restore to the standby mode, press the **Energy Saver** button.

Processing When Trouble Occurs

Very rarely, during use the display may go out, all the keys stop working, or some other trouble occur because of intense noise or a strong shock. If such trouble occurs, perform an All Clear operation. During installation, we recommend that you perform an All Clear operation. Below is the procedure for performing an All Clear operation.



When perform an All Clear operation, all the registered data is erased and all the service data is initialized.

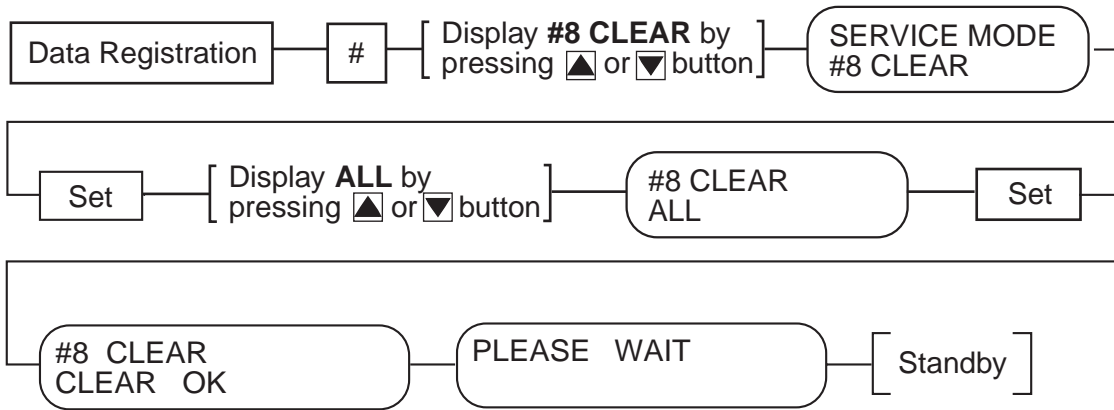

Figure 5-1 All Clear

1.5 Checking Operations

Copy operation

Check that normal images are printed.

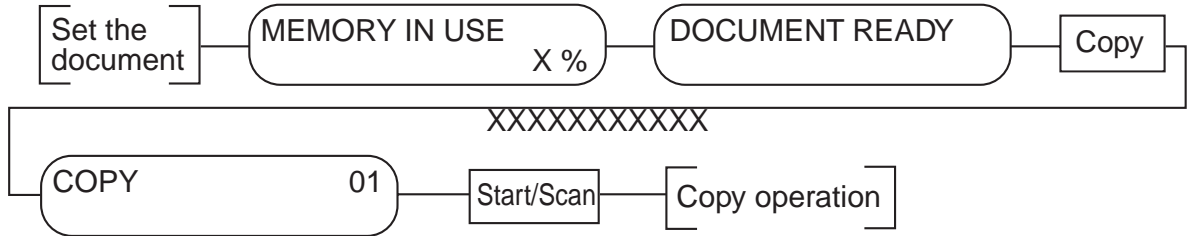

Figure 5-2 Copy Operation

Communication Test

Transmit to, and receive from other faxes, and check that images are sent normally for transmission, and are printed normally for reception.

Here is a procedure for a general communication test.

- (1) Pickup the handset or press the HOOK button, and check that you can hear the dial tone. If you cannot, check the line connections.
- (2) Dial the other fax and check that the line is connected. If you cannot connect with the other fax, check the line settings (tone/pulse).
- (3) Transmit and receive a document and check the operation and the image.

1.6 Moving the Fax Unit

Moving the Fax Unit

The fax unit is heavy. Be sure to follow these general guidelines when lifting the fax to move it or to install the optional Paper Feed Unit (PF-52), etc.

- Moving the fax unit requires two people.
- When you lift the fax, hold it by the handles on the right and left sides. Never try to lift the fax by gripping paper cassettes by the front and back sides.
- Grip firmly the handles by the parts close to the back of the fax unit as shown in the figure below, because the fax unit is heavier at the back.
- When you lift the fax, be sure not to tilt it forward because the paper cassette may slide out of the fax unit.
- Be sure to remove Paper Feed Unit (PF-52), if installed, before moving the fax and lift them separately.

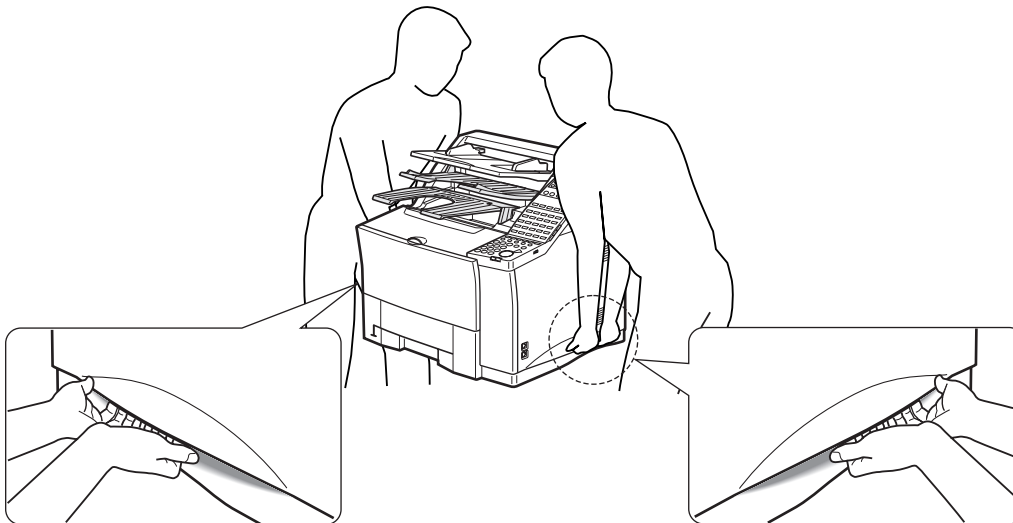

2. SERVICE TOOLS

2.1 Printer Driver Tester

2.1.1 Outline

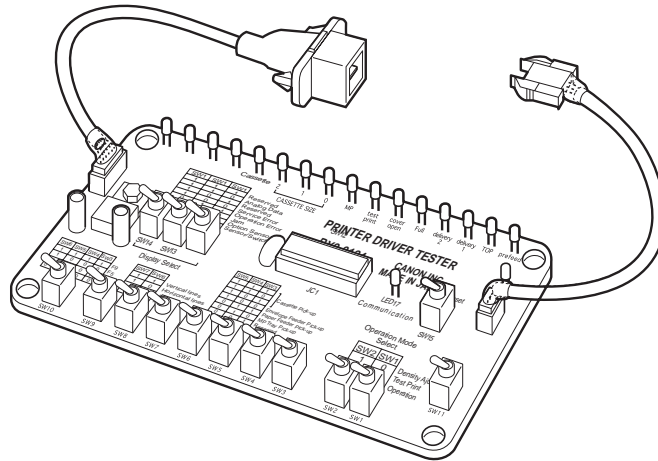

Figure 5-3 Printer Driver Tester

Printer driver tester is a special tool that operates the printer to check printer operations. It is also used with the thickness gauge to adjust installation position of the envelope multiple feed sensor of the envelope feeder. Its four main functions are as follow.

- a) Operates the printer to print all-black, vertical lines, horizontal lines, or all-white images.
- b) Monitors the state of the sensors in the printer and operates the printer.
- c) Displays error status sent from the engine controller (ECNT board) to the video controller with the LEDs on the tester when a malfunction occurs in the printer.
- d) Adjusts installation position of the envelope multiple feed sensor with a special tool, thickness gauge. (See *this Chapter 3.4.6 Installation Position Adjustment of Envelope Multiple Feed Sensor*)

2.1.2 Explanation of LEDs and Switches

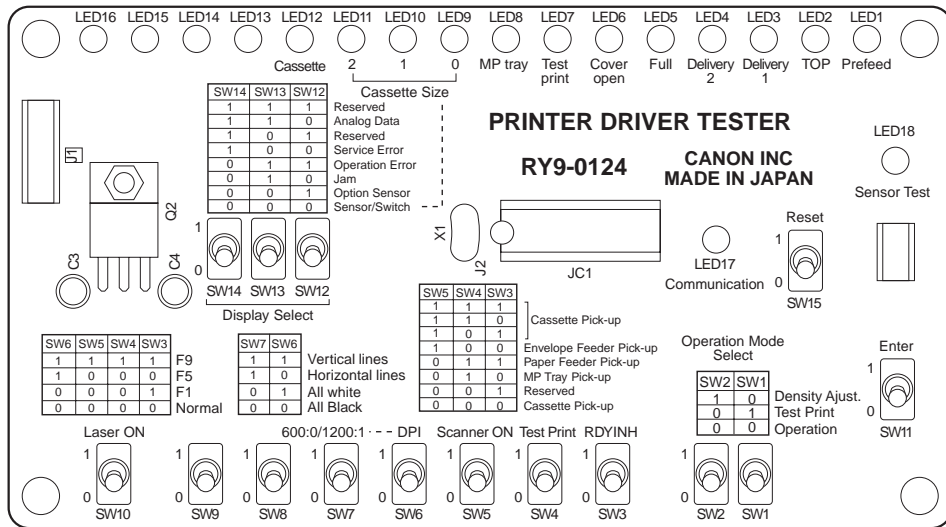

Figure 5-4 LEDs and Switches

LED1 to LED16

Monitors the state of the sensors and various status sent from the printer with the 16 LEDs.

LED17 (Communication)

Lights up when communicating with the printer.

LED18 (Sensor Test)

Used to adjust position of the envelope multiple feed sensor.

SW1 and SW2 (Operation Mode Select)

Set operation mode.

SW3 to SW9

Set various data sent to the printer.

SW10 (Laser ON)

Emits laser from the laser diode.

SW11 (Enter)

Enters the data set by SW3 to SW9.

SW12 to SW14 (Display Select)

Set display mode.

SW15 (Reset)

Resets the printer driver tester.

2.1.3. Operation

a) Connecting to the printer

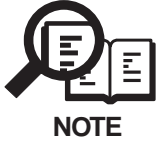

Before handling the printer driver tester, make sure to touch metallic parts of the printer to discharge electrical static as it may cause malfunctions or failures in the printer and the tester.

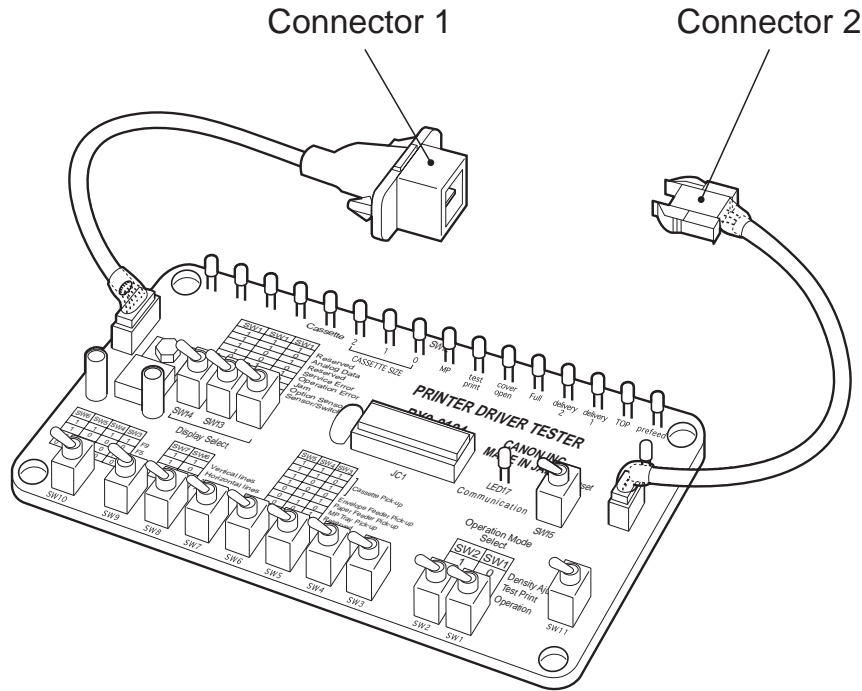
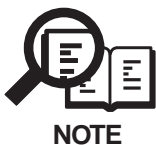

Figure 5-5 Connect Printer Driver Tester

- (1) Disconnect the power cord.
- (2) Connect the connector 1 of the tester to the envelope feeder connector in the printer. The seal on the connector 1 should be facing up when connected to the envelope feeder connector. Connect it to the duplexing unit connector on the back to check the envelope feeder operation. The seal on the connector 1 should be facing right (the left cover side) when connected to the duplexing unit connector.
- (3) Connect the power cord and operate the tester when the printer enters the standby mode.



Note that the connector of the tester fits into the connector on the wrong side. If the LEDs on the tester do not light up when conducting the step 2.1.3, reconnect the connector the other way around.

b) Setting the printer operations

Table 5-1 shows printer operations that can be set by combinations of switches on the printer driver tester.

Set the operation mode with SW1 and SW2 and various data with SW3 to SW9 according to the table 5-1. Contents set by SW3 to SW9 are sent to the printer by turning ON SW11, and the printer executes the set operations. Once SW11 has been turned ON, the set contents remain until canceled. If multiple settings are to be made, set them one by one turning ON SW11 each time.

To cancel the setting, set the corresponding switch back to “0” and then turn ON SW11 or disconnect the power cord.

For instance, a test print is executed when turning ON SW11 with SW1 and SW2 set to “0” and SW4 to “1”. The test print is continued until the setting is canceled by turning ON SW11 with SW4 set to “0”.

Table 5-1 Printer Operation Setting

	Operation selection	Test print selection				Density selection				
SW1	0	1				0				
SW2	0	0				1				
SW3	Ready inhibit (Note)	SW5	SW4	SW3	Paper pick-up source	SW6	SW5	SW4	SW3	Density
		0	0	0	Cassette	0	0	0	0	Normal mode
		0	0	1	—					
SW4	Test print	0	1	0	Multi-purpose tray	0	0	0	1	F1
		0	1	1	Paper feeder					
		1	0	0	Envelope feeder					
SW5	Scanner motor ON	1	0	1	Cassette	1	0	0	0	F5
		1	1	0	Cassette					
		1	1	1	Cassette	1	1	1	1	F9
		1	1	1	Cassette					
SW6	Switch resolution 600dpi: "0" 1200dpi: "1"	SW7	SW6	Test pattern		Change density directly with the above 4 bit data.				
		0	0	Vertical lines						
		0	1	Horizontal lines						
SW7	—	1	0	All-white		—				
		1	1	All-black						
SW8	—	Duplex test print				—				
SW9	—	—				—				



NOTE

To set the printer to enter ready inhibit mode at power-ON, set the mode using the switches and then turn ON the printer while holding SW11 to "1".

c) Monitoring the printer condition

Select items to monitor from the table 5-2 and 5-3. Make settings with SW12 to SW14 and monitor the printer condition with LED1 to LED16.

Table 5-2 Printer Condition (1)

	Sensor/switch information (Printer)	Sensor/switch information (Option)	Jam display
SW12	0	1	0
SW13	0	0	1
SW14	0	0	0
LED1	Pre-feed sensor Paper present	Paper feeder connected	Pick-up delay jam
LED2	Top of page sensor Paper present	Paper size detection switch (Lower) ON	Pick-up stationary jam
LED3	Fixing unit paper delivery sensor 1 Paper present	Paper size detection switch (Middle) ON	Delivery delay jam
LED4	Fixing unit paper delivery sensor 2 Paper present	Paper size detection switch (Upper) ON	Delivery stationary jam
LED5	Face-down tray paper full sensor Paper present	Paper feeder Paper present	Reverse delay jam
LED6	Door open detection switch ON	Envelope feeder connected	Reverse stationary jam
LED7	Test print switch ON	Envelope feeder Envelope present	Duplexing unit pick-up delay jam
LED8	Multi-purpose tray paper sensor Paper present	—	—
LED9	Paper size detection switch (Lower) ON	Duplexing unit connected	—
LED10	Paper size detection switch (Middle) ON	Reversed paper sensor Paper present	—
LED11	Paper size detection switch (Upper) ON	Duplexing unit pick-up sensor Paper present	—
LED12	Cassette Paper present	Face-up sensor	—
LED13	—	—	—
LED14	—	—	—
LED15	—	—	—
LED16	—	—	—

Table 5-3 Printer Condition (2)

	Status information 1	Status information 2	Analog data
SW12	1	0	0
SW13	1	0	1
SW14	0	1	1
LED1	No paper in the specified pick-up source	Scanner failure	A/D data of VR501 (Note 7) bit 0 (LSB)
LED2	No toner cartridge	Main motor failure	A/D data of VR501 bit 1
LED3	Test print	Fan motor failure	A/D data of VR501 bit 2
LED4	Door open	Duplex fan motor failure	A/D data of VR501 bit 3
LED5	Paper jam	Fixing unit failure (Warm-up error)	A/D data of VR501 bit 4
LED6	Sleep	Fixing unit failure (Abnormally low temperature)	A/D data of VR501 bit 5
LED7	Wait	Fixing unit failure (Abnormally high temperature)	A/D data of VR501 bit 6
LED8	—	Fixing unit failure (Detection circuit failure)	A/D data of VR501 bit 7 (MSB)
LED9	No toner warning	—	—
LED10	Face-down tray paper full warning	—	—
LED11	BD error	Pick-up unit illegal operation (Note 1)	—
LED12	Paper size mismatch	Delivery unit illegal operation (Note 2)	—
LED13	Paper feed failure	Cassette illegal operation (Note 3)	—
LED14	—	Duplexing unit illegal connection (Note 4)	—
LED15	—	Paper feeder illegal connection (Note 5)	—
LED16	Multiple envelopes fed from envelope feeder	Envelope feeder illegal connection (Note 6)	—



NOTE

1. The specified pick-up source was eliminated from the pick-up unit configuration.
2. Any of the following four has taken a place.
 - The specified delivery unit was eliminated from the delivery unit configuration.
 - Face-up tray was opened when the duplex delivery has been selected.

- Two sheets of paper are fed to the duplexing unit when the duplex delivery has been selected.
 - The duplexing unit was eliminated from the delivery unit configuration when the option delivery slot has been selected.
3. The cassette is not set in the printer when the paper feeder is selected as the paper pick-up source.
 4. The duplexing unit is not connected correctly.
 5. The paper feeder is not connected correctly.
 6. The envelope feeder is not connected correctly.
 7. Monitored value set by VR501 on the engine controller. The value is expressed by 8 bit data (256 steps).
The value of the data becomes +40 (-40) when the start position of the laser is moved backward (forward) by 1 mm via VR501.
-

3. OPTION

3.1 Option Memory VII (4M-BYTE)

3.1.1 Safety and precautions

Damage due to electrostatic discharge

Electrostatic charge in the human body is the cause of damage to electronic parts as well as changes in their characteristics. When attaching / removing memory boards, be sure to take measures against electrostatic discharge by using a wrist strap, etc. If memory boards are handled when an electrostatic charge is present, the electronic parts will be damaged.



REFERENCE

Countermeasures for Electrostatic Discharge

For details regarding countermeasures for electrostatic discharge, please refer to *Chapter 1, 2.3.1 Damage due to electrostatic discharge*.

3.1.2 Service operations

a) External view

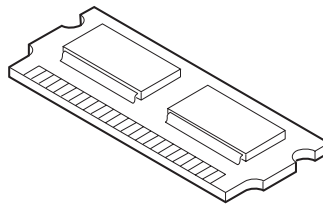

4M-Byte

Figure 5-6 External View



NOTE

Memory board extension can be done in combinations of 1 or 2 memory boards, resulting in 4M (4M x 1 board) and 8M (4M x 2 boards) of memory. Prepare needed memory boards according to the amount of memory to be extended.

b) Installation

b-1) Unpacking

Check that the box contains the memory board.

b-2) Preparation

Perform the operations below before attaching the memory boards.

- (1) Output all image data if there is any remaining in image memory.



When attaching memory boards, it is necessary to disable memory backup, so the complete contents of image memory will be cleared. Output all image data if there is any remaining in image memory.

- (2) Disconnect the power cord of the fax unit at the power source.
- (3) Disconnect the modular jack cord (telephone line) from the fax.
- (4) Remove the one screw and remove the right cover.

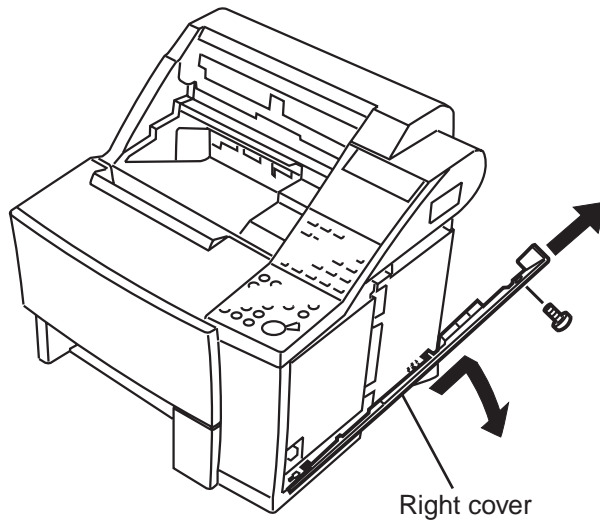

Figure 5-7 Preparations for Installation 1

- (5) Remove the six screws and remove the shield cover.

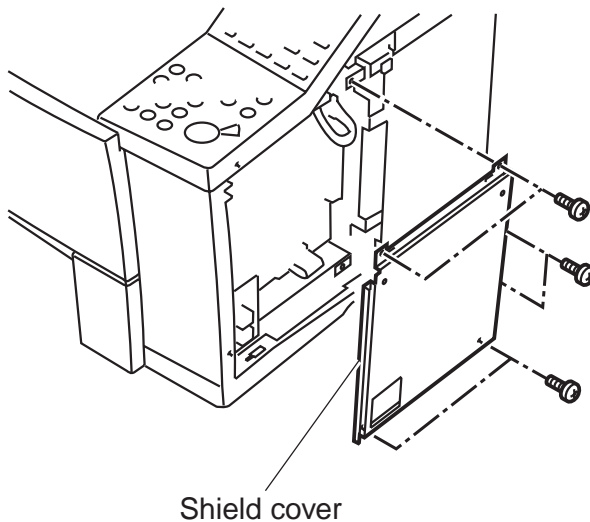

Figure 5-8 Preparations for Installation 2

b-3) Attaching memory boards

- (1) To disable memory backup, remove the jumper plug on the SCNT board jumper switch (JP1).



When the jumper plug is attached to the SCNT board jumper switch (JP1) even when the power is turned off, the voltage of the Vanadium-Lithium secondary battery is still being output to the memory extension connector (J1). If a memory board is loaded in this condition, the memory IC will suffer damage, so be sure to remove the jumper plug.

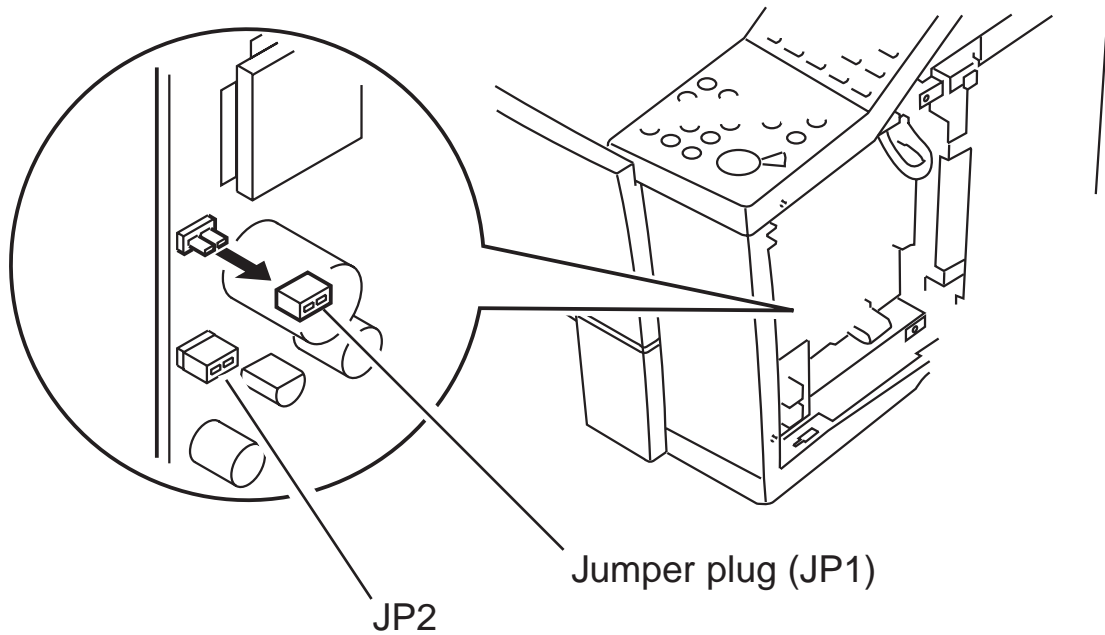

Figure 5-9 DRAM Boards Installation (1)

- (2) To install the first DRAM board, follow the steps ① and ② shown below.
To install the second DRAM board, follow the steps ③ and ④ shown below.

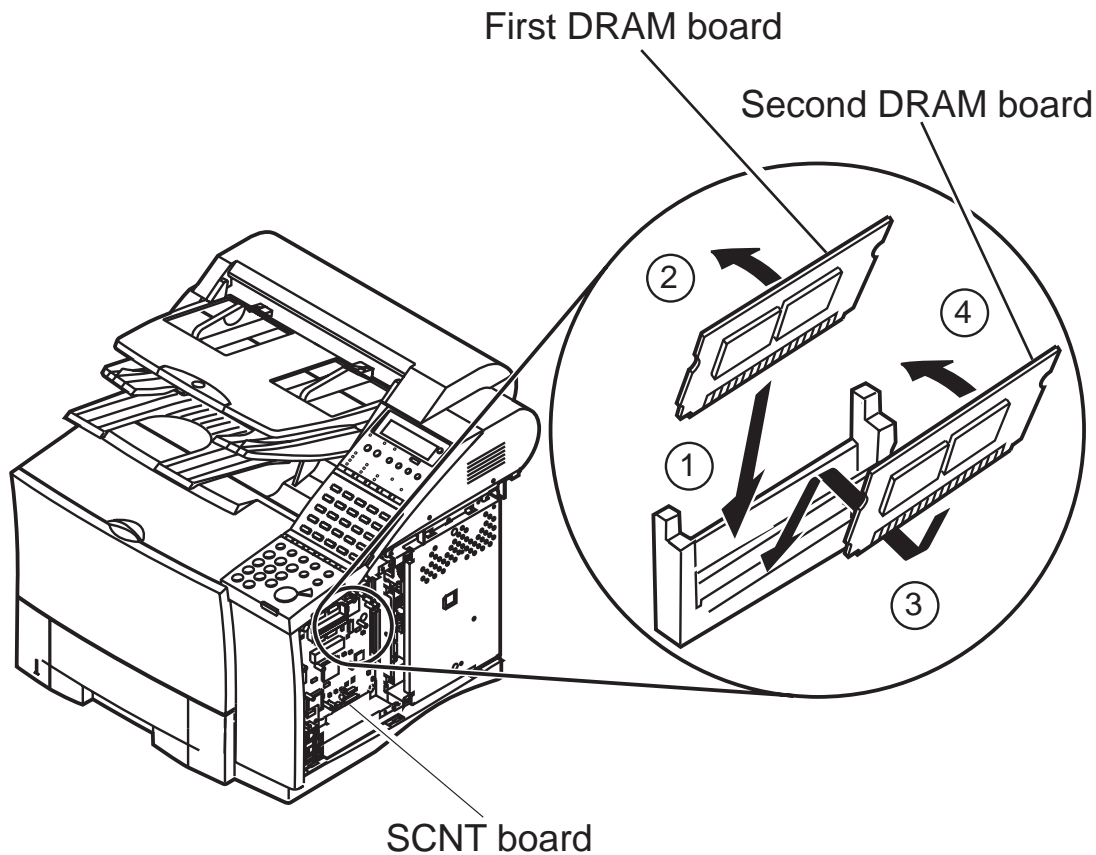

Figure 5-10 DRAM Boards Installation (2)



Insert the DRAM board into the socket in the direction indicated by arrow ① or ③, then push it in the direction indicated by arrow ② or ④ until it is fixed in place.

- (3) Install jumper plug JP1 on the SCNT board.
- (4) Fasten the shield cover in place with the four screws.
- (5) Fasten the right cover in place with the one screw.
- (6) Connect the modular jack cord (telephone line) to the fax.
- (7) Plug in the fax.

b-4) Check after DRAM boards installation

After installing the DRAM boards, carry out the following procedure to ensure that the DRAM boards are properly identified by the fax.

- (1) Referring to the flow chart, enter test mode D-RAM test [1].

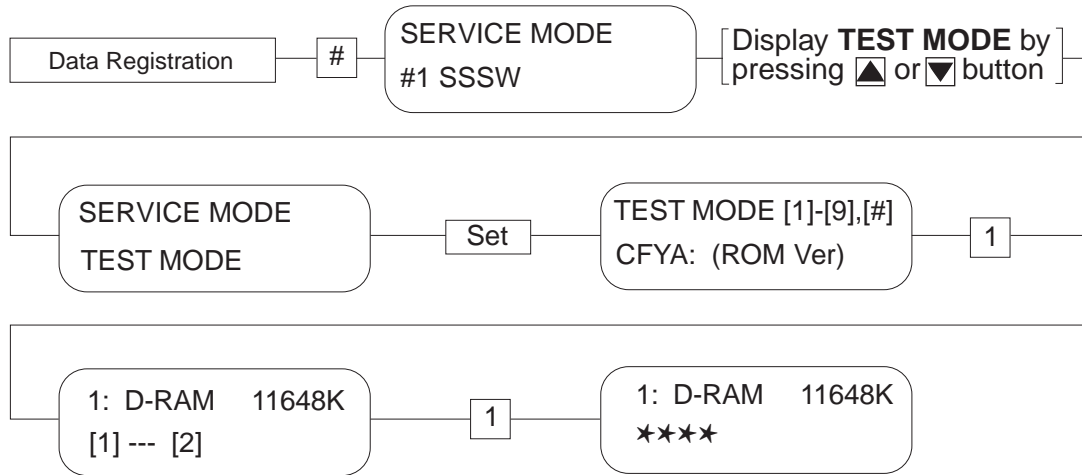

Figure 5-11 Flowchart of D-RAM test 1

- (2) When D-RAM test [1] is entered, check the D-RAM write-in and read-out. Confirm that the display shows the extended memory capacity value, and that the check completes with “no error”.

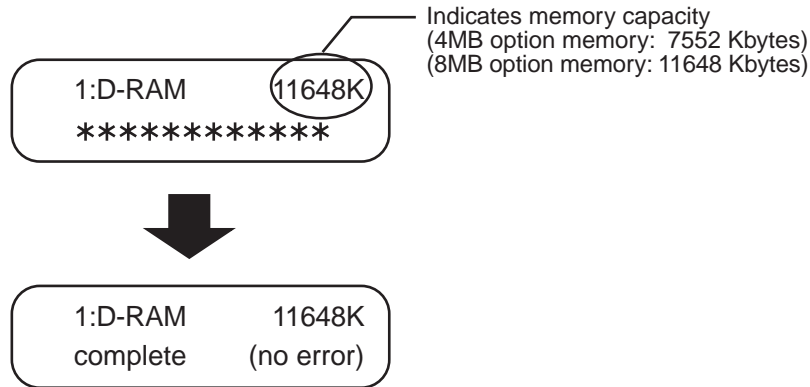

Figure 5-12 D-RAM Board Installation Check

- (3) After confirming this, push the Stop button, then push the Clear button, which will put the machine into a standby condition.
- (4) If the process does not complete normally, return to *b-3) Attaching memory boards*, re-attach the memory board, and then re-check with the D-RAM test.

b-5) Removing the memory board

When removing the memory board, perform the steps in *b-3) Attaching memory boards* in reverse order. Be sure to remove the memory board only after turning the power off and removing the jumper plug on SCNT board jumper switch (JP1).



If the memory board is removed with the jumper plug attached to the SCNT board jumper switch, the memory board will suffer damage.

3.1.3 Technical information

a) Configuration and construction

1. Product name OPTION MEMORY VII (4MB)

2. External view

4Mbyte

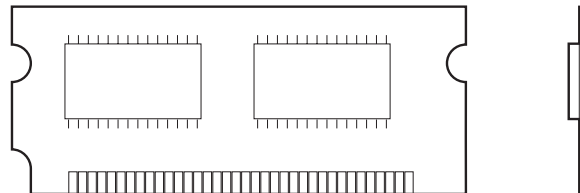

Figure 5-13 DRAM Board (4MB)

b) Specifications

Type of memory	DRAM
Capacity	2Mbyte × 2

3.1.4 Maintenance and service

a) Troubleshooting

The fax does not recognize the DRAM boards even when the test mode D-RAM test is executed.

- Solutions:**
- (1) Check that the DRAM boards are securely connected.
 - (2) Replace the DRAM board.
 - (3) Replace the SCNT board.

b) Signal description

SCNT board (J1) ↔ Memory board

J1	Memory	Signal name	Description
A1	— 1	DGND	Ground
A2	— 2	VD0	Data signal
A3	— 3	VD1	Data signal
A4	— 4	VD2	Data signal
A5	— 5	VD3	Data signal
A6	— 6	VD4	Data signal
A7	— 7	VD5	Data signal
A8	— 8	VD6	Data signal
A9	— 9	VD7	Data signal
A10	→ 10	+VB	Logic drive voltage
A11	— 11	N.C	Not connected
A12	— 12	AX0	Address/data signal
A13	— 13	AX1	Address/data signal
A14	— 14	AX2	Address/data signal
A15	— 15	AX3	Address/data signal
A16	— 16	AX4	Address/data signal
A17	— 17	AX5	Address/data signal
A18	— 18	AX6	Address/data signal
A19	— 19	AX10	Address/data signal
A20	— 20	N.C	Not connected
A21	→ 21	VD8	Data signal
A22	— 22	VD9	Data signal
A23	— 23	VD10	Data signal
A24	— 24	VD11	Data signal
A25	— 25	VD12	Data signal
A26	— 26	VD13	Data signal
A27	— 27	VD14	Data signal
A28	— 28	AX7	Address/data signal
A29	— 29	N.C	Not connected
A30	→ 30	+VB	Logic drive voltage
A31	— 31	AX8	Address/data signal
A32	— 32	AX9	Address/data signal

SCNT board (J1) ↔ Memory board

J1	Memory	Signal name	Description
A33	— 33	N.C	Not connected
A34	— 34	N.C	Not connected
A35	— 35	VD15	Data signal
A36	— 36	N.C	Not connected
A37	— 37	VD0	Data signal
A38	— 38	VD1	Data signal
A39	— 39	DGND	Ground
A40	→ 40	nCASL	Column address/low-order byte access
A41	→ 41	nCASL	Column address/low-order byte access
A42	→ 42	nCASH	Column address/high-order byte access
A43	→ 43	nCASH	Column address/high-order byte access
A44	→ 44	nRAS2	Row address strobe signal No.2
A45	— 45	N.C	Not connected
A46	— 46	N.C	Not connected
A47	→ 47	nFWE	XWE signal to DRAM
A48	— 48	N.C	Not connected
A49	— 49	VD2	Data signal
A50	— 50	VD3	Data signal
A51	— 51	VD4	Data signal
A52	— 52	VD5	Data signal
A53	— 53	VD6	Data signal
A54	— 54	VD7	Data signal
A55	— 55	N.C	Not connected
A56	— 56	VD8	Data signal
A57	— 57	VD9	Data signal
A58	— 58	VD10	Data signal
A59	— 59	VD12	Data signal
A60	— 60	VD11	Data signal
A61	→ 61	+VB	Logic drive voltage
A62	— 62	VD13	Data signal
A63	— 63	VD14	Data signal
A64	— 64	VD15	Data signal
A65	— 65	N.C	Not connected
A66	— 66	N.C	Not connected
A67	— 67	N.C	Not connected
A68	— 68	N.C	Not connected
A69	— 69	N.C	Not connected
A70	— 70	N.C	Not connected
A71	— 71	N.C	Not connected
A72	— 72	DGND	Ground



NOTE

The J1 connector on the SCNT board has two rows A and B and has a total of 144 pins. Since rows A and B have similar pin layout , only different pins are shown below:

B34 :nRAS2 B44 :nRAS1

3.2 Verification Stamp Unit

3.2.1 Service operations

a) External View

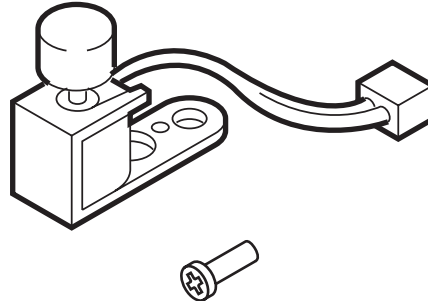

Figure 5-14 External View

b) Installation

b-1) Unpacking

Check that the box contains the stamp unit and one screw.

b-2) Attachment to the main unit

- (1) Disconnect the power cord of the fax unit at the power source.
- (2) While holding the upper reader frame and the middle reader frame open with one hand, use one finger of your other hand to gently push in the stopper to separate it from the stub on the fax machine, and open the upper reader frame and the middle reader frame.

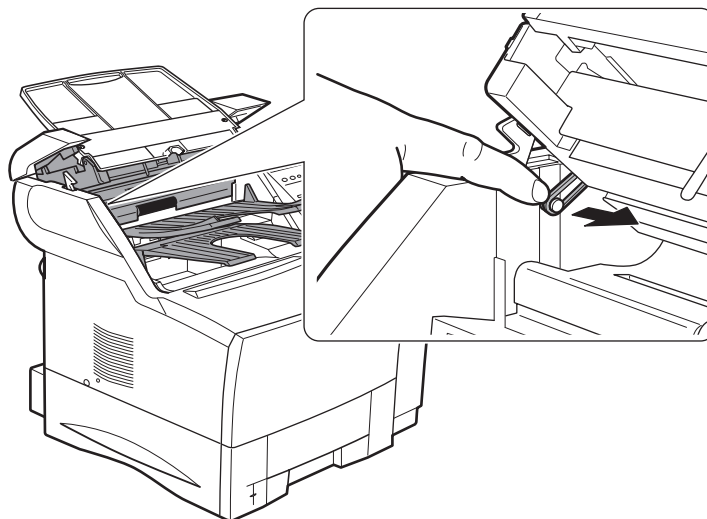

Figure 5-15 Attachment to the Main Unit 1

- (3) Remove the three screws, and remove the lower reader cover.

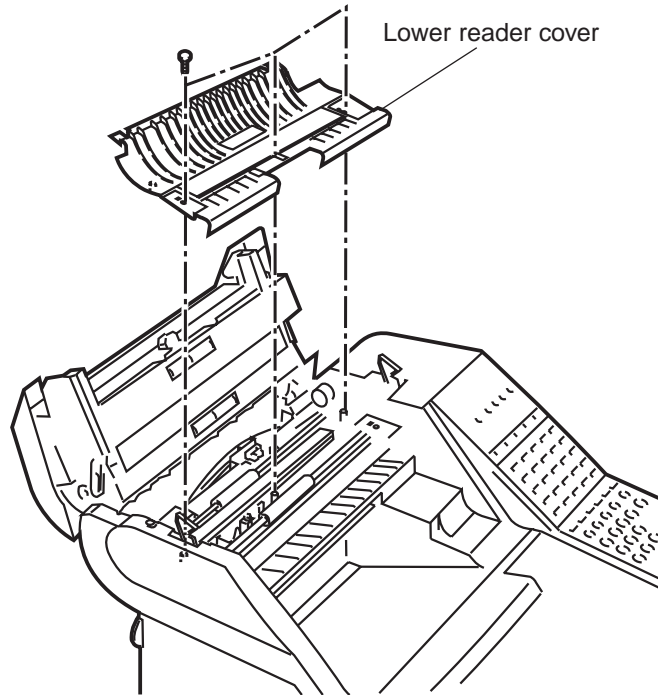

Figure 5-16 Attachment to the Main Unit 2

- (4) Connect the stamp unit connector cable to the main unit, and fasten the stamp unit with the one screw as shown below.

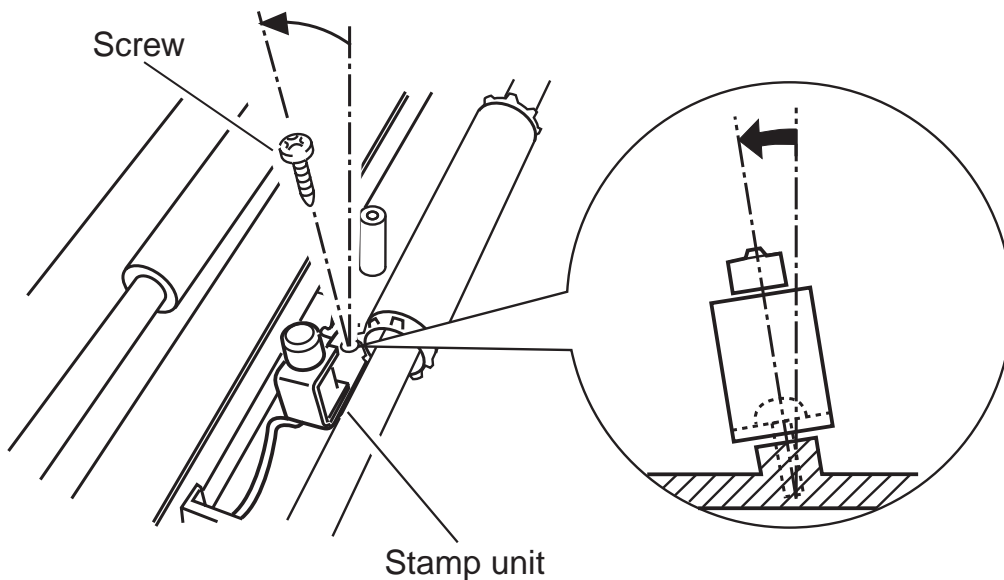

Figure 5-17 Attachment to the Main Unit 3



NOTE

As shown in the Figure, angle the boss slightly, insert the screw, and fix the stamp unit into place.

- (5) Remove the cap from the stamp unit.

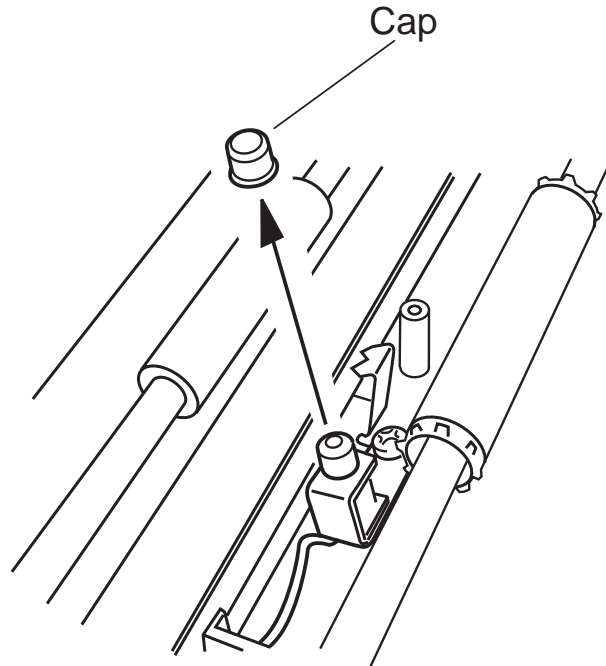

Figure 5-18 Attachment to the Main Unit 4

- (6) Fasten the lower reader cover in place with the three screws.
- (7) Place the end of the stopper over the end of the stub so it locks in place, and close the upper reader frame.

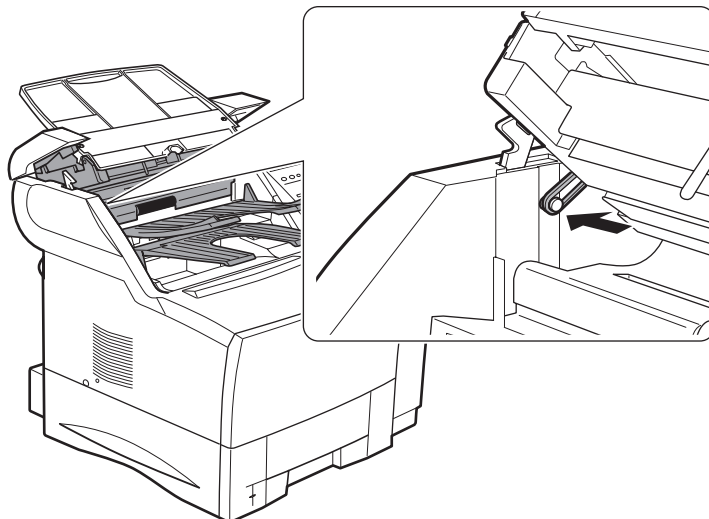

Figure 5-19 Attachment to the Main Unit 5

- (8) Connect the power cord of the fax unit at the power source.

(9) In the service mode, set #1SSSW SW06 Bit3 to 1.

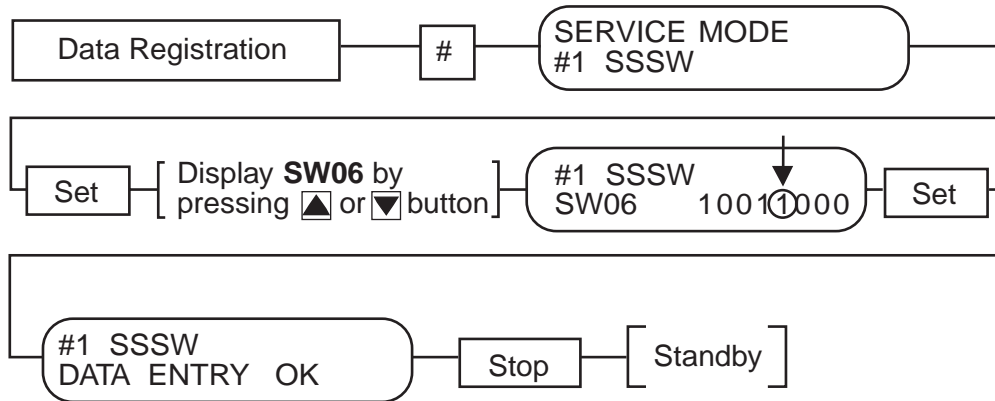

Figure 5-20 Flowchart of Changing SSSW

b-3) Operation check

After setting 8. TX STAMP of USER DATA TX SETTINGS to “ON”, or after pressing the Stamp button on the operation panel and turning the stamp function “ON” using the search button, fax a document to verify that a stamp is put at the bottom of the document scanning surface during scanning.

3.2.2 Maintenance and service

a) Signal description

STAMP unit ↔ SCNT board (J8)

Stamp		J8	Signal name	Description
1	←	1	STAMP+24V	STAMP+24V
2	←	2	STAMPGND	STAMP ground

3.3 Paper Feed Unit PF-52

3.3.1 Safety and precautions

a) Personal precautions

During servicing, if you have to operate the sensor arm, be careful to keep hair, clothes, accessories, etc. from becoming wrapped up in moving and rotating parts.

- The cassette pickup roller, cassette separation roller, and cassette feed roller are rotated by the main motor.
- The cassette pickup solenoid controls the cassette pickup roller.

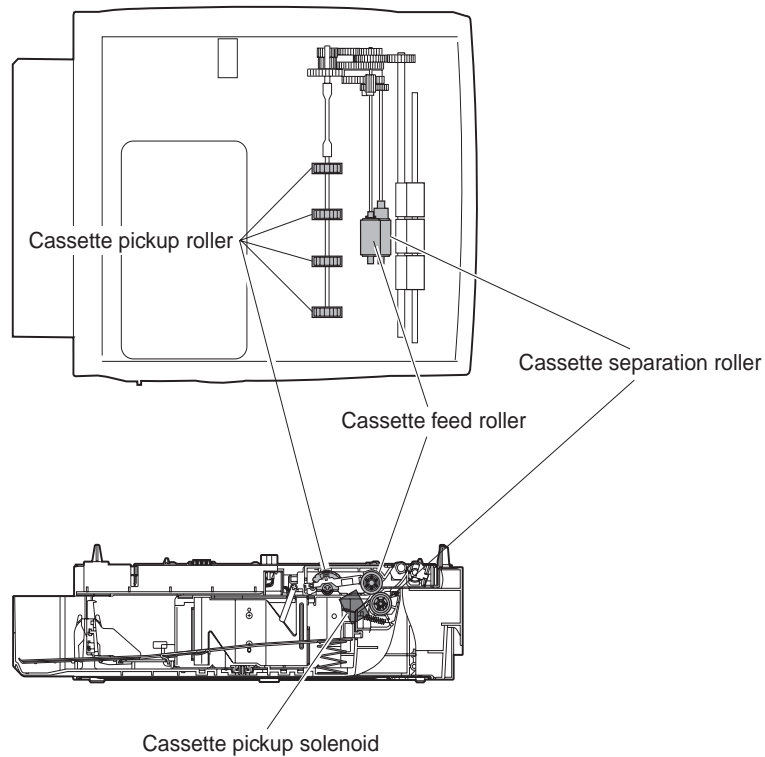

Figure 5-21 Moving and Rotating Parts

3.3.2 Service operations
a) External Views

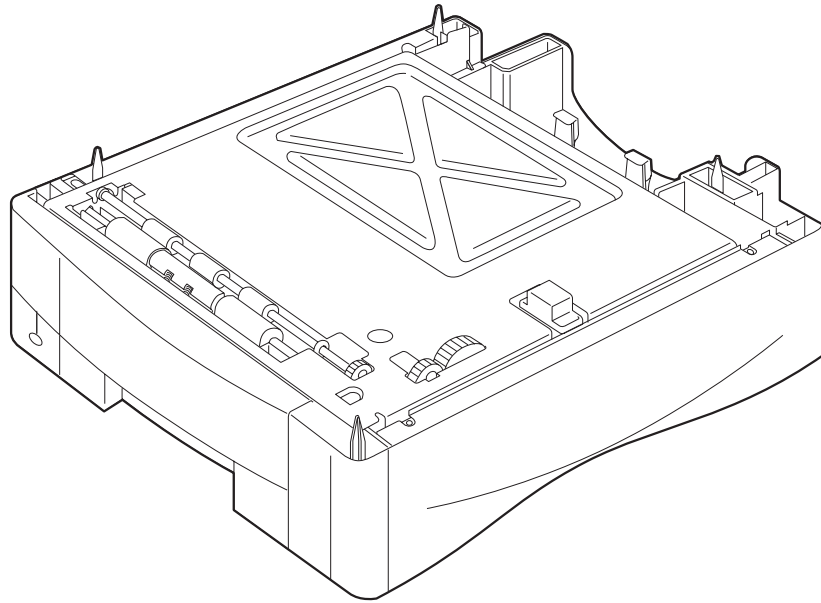

Figure 5-22 External View

b) Installation

b-1) Unpacking



REFERENCE

Please refer to item Installing Paper Feed Unit (PF-52) in *this Chapter, 1.4 Assembling the Fax*, for installation.

b-2) Attachment to the main unit



REFERENCE

Please refer to item Installing Paper Feed Unit (PF-52) in *this Chapter, 1.6 Moving the Fax Unit*, for installation.

b-3) Cassette installation

- (1) When you plug the power cord into a socket, “SUPPLY REC. PAPER” is displayed and the Alarm lamp blinks. Check that the cassette pickup roller is at its initial position.

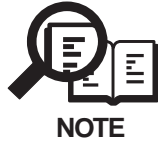

After connecting the paper feed unit PF-52 and install the toner cartridge, when you plug the power cord, the main unit automatically detects that the feed unit is connected and the cassette pickup roller is set to its initial position. This initial position is as shown in below.



After connecting the feed unit, if you load the cassette when the cassette pickup roller is not in its initial position, then the cassette will strike the roller and may break it. Always check that the roller is in its initial position before loading the cassette.

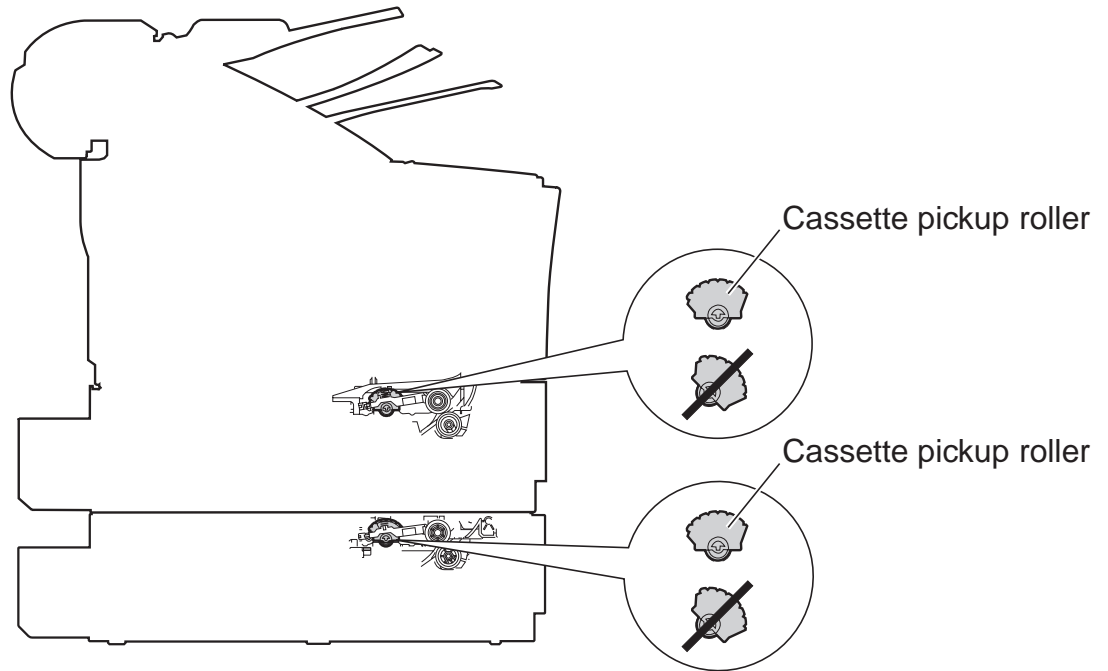

Figure 5-23 Pickup Roller Initial Position

b-4) Operation Check

Empty all the recording paper other than that in the cassette 2, make a copy, and check that the recording paper is picked up correctly.

3.3.3 Technical information

a) Configuration and construction

External structure

Item	Dimensions and weight	Remarks
Dimensions	15.35" (W) × 19.41" (D) × 4.96" (H) (390 × 493 × 126 mm)	With cassette
Weight	approx. 15.4 lbs (7 kg)	

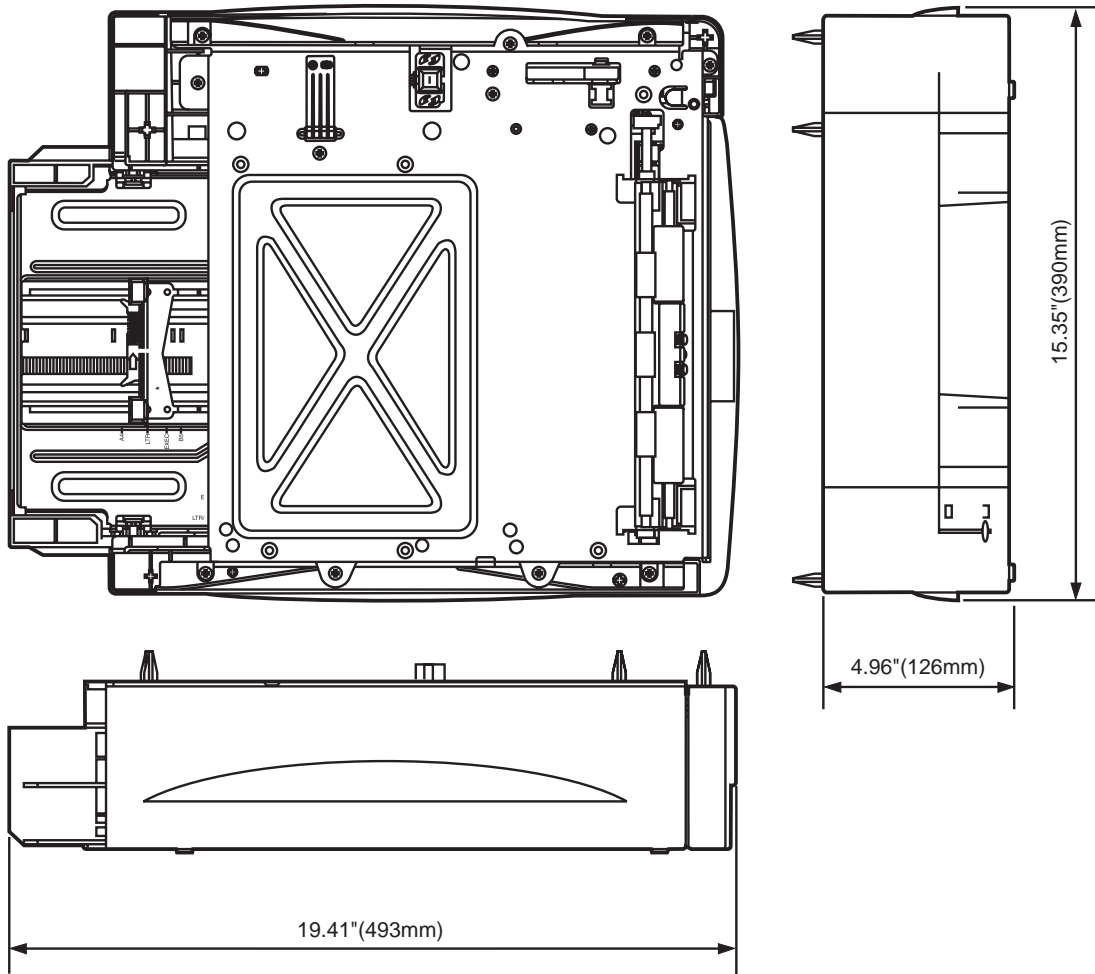

Figure 5-24 External View

b) Specifications

Recording paper dimensions

Letter	8.50"(W) × 10.98"(L) (216 × 279 mm)
Legal	8.50"(W) × 14.00"(L) (216 × 356 mm)
A4	8.27"(W) × 11.69"(L) (210 × 297 mm)
B5-JIS	7.17"(W) × 10.12"(L) (182 × 257 mm)
Executive	7.25"(W) × 10.50"(L) (184 × 267 mm)
Weight	64~90 g/m ²

Recording paper cassette capacity

500 sheets (max.), or 2.20" (56mm) in height; of weight 80g/m² paper.

Recommended recording paper

Canon Copier LTR/LGL Premium Paper

Weight	75 g/m ²
Paper size	Letter, Legal
Manufactured by	BOISE CASCADE

KANGAS

Weight	80 g/m ²
Paper size	A4
Manufactured by	KANGAS

NEUSIEDLER Canon Paper

Weight	80 g/m ²
Paper size	A4
Manufactured by	NEUSIEDLER

3.3.4 Operations

a) Functions

a-1) Recording paper pickup function

The paper feeder is driven by the main motor of the fax via the gear.

When the nPRNT signal is sent to the ECNT board from the SCNT board, the main motor of the printer starts rotation. When the main motor reaches its prescribed speed, the paper feeder driver PCB receives the pick-up command from the ECNT board, and the paper feeder pick-up solenoid is turned ON. As a result, the pick-up roller, feed roller, and separation roller are driven by the main motor rotation.

a-2) No recording paper detection function

The cassette recording paper sensor in the option feeder detects whether or not there is recording paper in the cassette.

a-3) Recording paper size and no cassette detection function

The paper size in the cassette and whether the cassette is installed are detected by the three switches (SW800, 801, 802) on the paper size detection board 2.

b) Structures

See the description of the *Chapter 3, 2.4 Paper Load Section, b) Structures*.

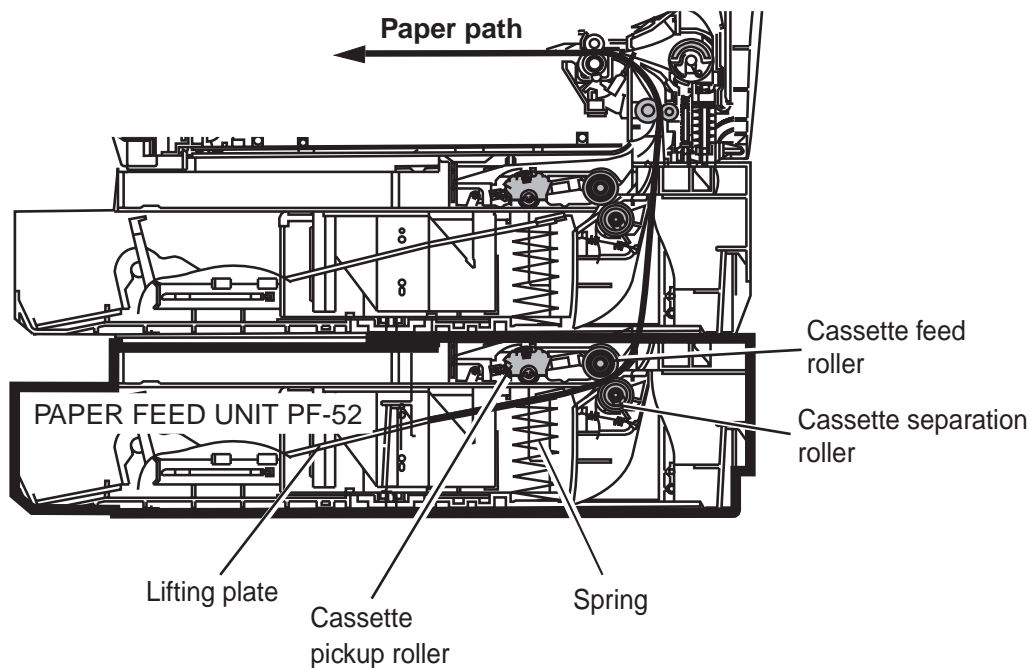

Figure 5-25 Cross-Sectional Diagram

c) Arrangement of switches

Paper size	SW801	SW802	SW803	
No cassette	OFF	OFF	OFF	
LEGAL	OFF	OFF	ON	
Executive	OFF	ON	OFF	(Available for printer function.)
LETTER	OFF	ON	ON	
Other	ON	OFF	OFF	(Available for printer function.)
Custom	ON	OFF	ON	(Available for printer function.)
B5	ON	ON	OFF	(Available for printer function.)
A4	ON	ON	ON	

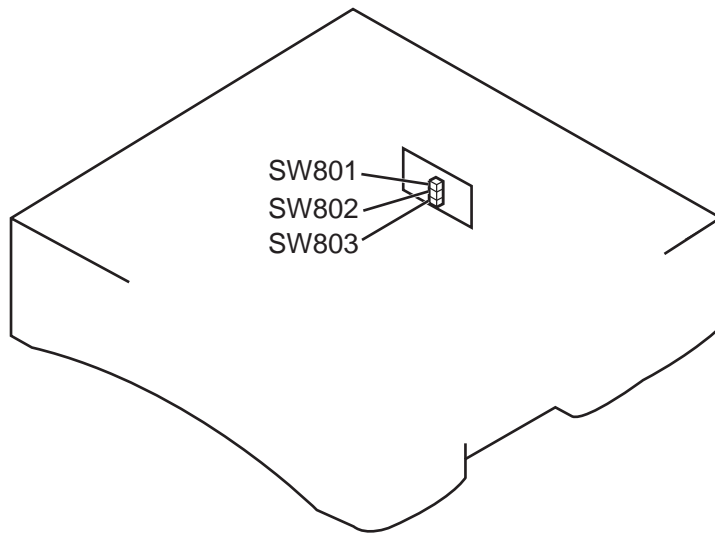

Figure 5-26 Arrangement of Switches

d) Electrical circuit section

The operation sequences of the paper feeder are controlled by the paper feeder driver. A 4-bit microprocessor is used in the paper feeder driver, which controls the sequences of the paper feeder and the serial communication with the engine controller (ECNT board) of this fax.

The engine controller outputs the pick-up command to the paper feeder driver at the necessary timing. The paper feeder driver drives the solenoid in response to the command. The paper feeder driver also sends back the status of the paper feeder to the engine controller.

This fax supplies +24VDC to the paper feeder. The paper feeder driver generates +3.3V for the ICs based on this +24V.

The flow of input/output signals to/from the paper feeder driver PCB is as shown below.

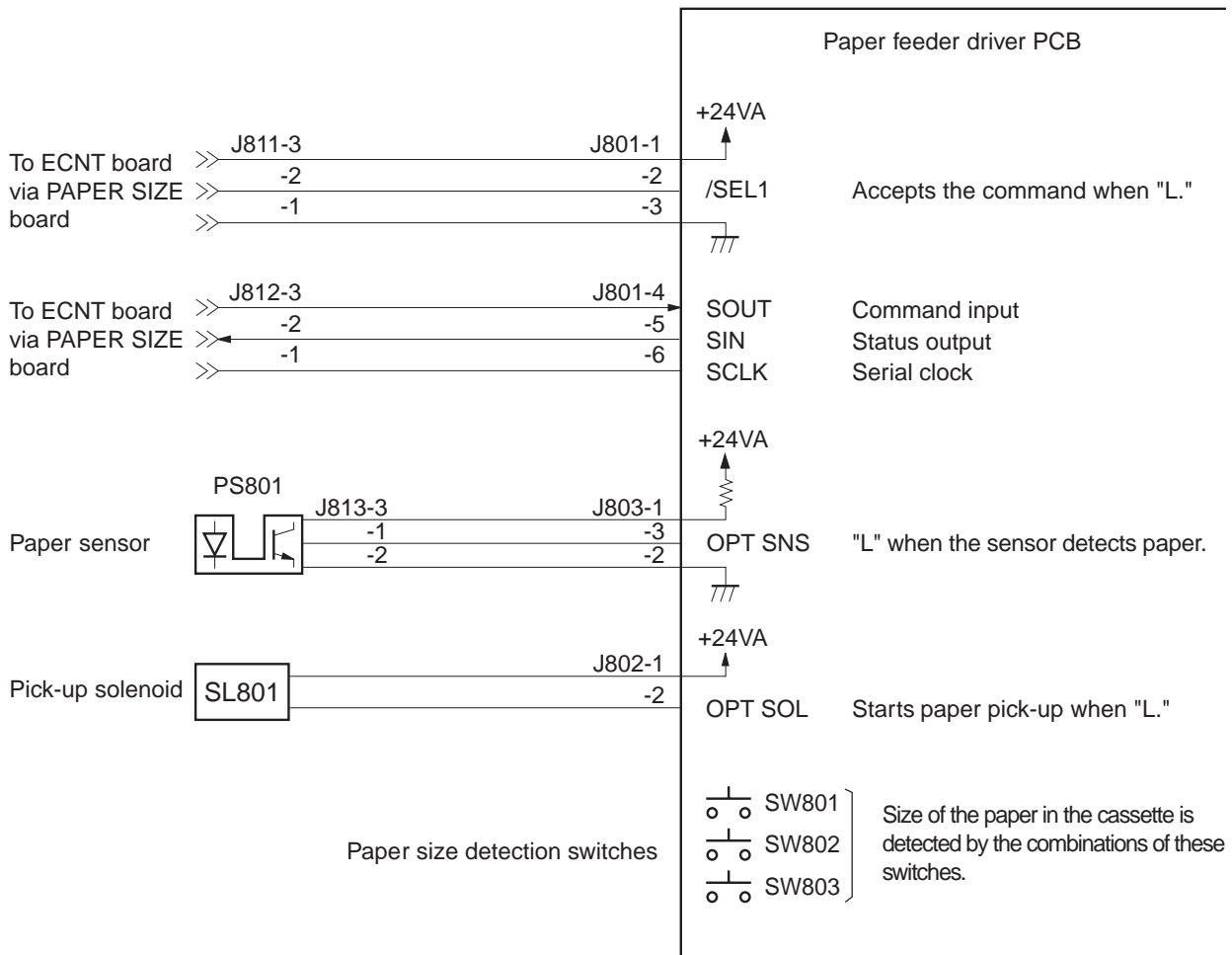

Figure 5-27 Electrical Circuit Section

3.3.5 Maintenance and service

a) Troubleshooting

The fax main unit does not detect that the PAPER FEED UNIT PF-52 is mounted.

- Solutions:**
- (1) Check the connection between the main unit and the paper size detection board 2.
 - (2) Check the connection between J811, J812 on the paper feeder connector and J801 on the paper size detection board 2.
 - (3) Check the connection between J104, J105 on the paper feeder connector and J601 on the paper size detection board 1.
 - (4) Check the connection between J72 on the ECNT board and J603 on the paper size detection board 1.
 - (5) Replace the paper size detection board 2.
 - (6) Replace the paper size detection board 1.
 - (7) Replace the ECNT board.

Recording paper is not picked up.

- Solutions:**
- (1) Check the connection between the main unit and the paper size detection board 1.
 - (2) Check the connection between J811, J812 on the paper feeder connector and J801 on the paper size detection board 2.
 - (3) Check the connection between J104, J105 on the paper feeder connector and J601 on the paper size detection board 1.
 - (4) Clean the rollers (cassette pick-up roller, cassette separation roller and feed roller) if dirty.
 - (5) Replace it if worn or deformed. The cassette separation roller and the cassette feed roller are to be replaced together.
 - (6) Replace the cassette claw if deformed.
 - (7) Check the gears of the main unit and the feed unit, and replace any damaged gears.
 - (8) Check the connection between the pick-up solenoid and J802 on paper size detection board 2.
 - (9) Replace the pick-up solenoid if the resistance between J802-1 and J802-2 is not approx. 110 ohm.
 - (10) Replace the paper size detection board 2.
 - (11) Replace the paper size detection board 1.
 - (12) Replace the ECNT board.

b) Signal description

Paper size detection board 2 (J801) ↔ Paper size detection board 1 (J601)

J801	J601	Signal name	Description
1	→ 6	+24V	Paper feeder unit drive voltage
2	← 5	nSEL1	Paper feed select signal
3	— 4	GND	Ground
4	← 3	SOUT	Serial output data
5	→ 2	SIN	Serial input data
6	← 1	SCLK	Serial clock signal

Paper size detection board 2 (J802) ↔ Cassette pick-up solenoid

J802	Solenoid	Signal name	Description
1	→ 1	+24V	Cassette pick-up solenoid drive voltage
2	→ 2	OPT SPL	Cassette pick-up solenoid drive signal

Paper size detection board 2 (J803) ↔ Cassette recording paper sensor

J803	Sensor	Signal name	Description
1	→ 1	OPT DR	Cassette recording paper sensor drive voltage
2	— 3	GND	Ground
3	← 3	OPT SNS	Cassette recording paper sensor detection signal (H: No recording paper, L: Recording paper)

3.3.6 Recording Paper Size Priority

a) Cassette selection switches

Here are the two cassette selection switch items.

Switch A: divided recording

Enables/disables recording of received images onto recording paper with a length shorter than the received/copied length.

Switch B: margin recording

Enables/disables recording with margins of received images onto recording paper with a length longer than the received/copied length.



NOTE

When the print image can be printed on multiple recording paper sizes, the smallest recording cassette takes priority.

When printing divided across multiple pages, the recording paper size is selected giving priority to the size that will require the fewest pages.

The second and subsequent pages for divided printing use the same size recording paper as the first page. If enough recording paper of that size is not available, memory reception is used.

Recording paper is selected for received/copied images with the following procedure.

- 1) When set to Automatic Reduction with the user data:
The minimum size that can record the print image without data loss from the actual size to the maximum reduction
When set to No Automatic Reduction with the user data:
The minimum size that can record the print image in the data loss range at the actual size
- 2) The minimum size that can record the print image without data loss at the actual size



REFERENCE

For details on the reduction function, see *the FACSIMILE BASIC•INTER SUPPLEMENT 2 (Rev. 0) (supplied separately)*.

b) Reading the recording paper size table

When the recording paper size is determined with reduction, the combination of user data cassette selection switches A and B determine the priority order for the recording paper actually printed and the contents of printing. Below are examples of how to read the recording paper size table that shows this data.

Reception image size: A4

Cassette switches			
A	B	A4/Letter	Letter/Legal
OFF	OFF	1) Automatic reduction (Letter) 2) <u>Memory reception</u> (A4)	1) Automatic reduction (Letter) 2) Memory reception (Legal)

Figure 5-28 Reading the Recording Paper Size Table

① Priority order

The printed recording paper priority is determined by the contents of user data and service data settings.

The recording paper indicated by 2) is selected when there is none of the recording paper indicated by 1). When the recording paper indicated in the print recording paper column all runs out, the reception images are received into memory.

② Print recording paper size

Indicates the size of the recording paper on which the reception images are printed.

③ Contents of printing

Memory reception: Compulsory memory reception
 Automatic reduction: The optimum reduction ratio (70~100%) is obtained from the length of the received image and the received image is reduced to that reduction ratio.
 Actual size: Printed out in actual size.

④ Recording paper cassette size

Indicates the size of the recording paper loaded in the side cassette and the front cassette.

c) Printed recording paper table
Reception image size: A4

Cassette switches			
A	B	A4/Letter	Letter/Legal
OFF	OFF	1) Actual size (A4) 2) Automatic reduction (Letter)	1) Automatic reduction (Letter) 2) Memory reception (Legal)
OFF	ON	1) Actual size (A4) 2) Automatic reduction (Letter)	1) Automatic reduction (Letter) 2) Actual size (Legal)
ON	OFF	1) Actual size (A4) 2) Automatic reduction (Letter)	1) Automatic reduction (Letter) 2) Memory reception (Legal)
ON	ON	1) Actual size (A4) 2) Automatic reduction (Letter)	1) Automatic reduction (Letter) 2) Actual size (Legal)

Reception image size: Letter

Cassette switches			
A	B	A4/Letter	Letter/Legal
OFF	OFF	1) Actual size (Letter) 2) Memory reception (A4)	1) Actual size (Letter) 2) Memory reception (Legal)
OFF	ON	1) Actual size (Letter) 2) Actual size (A4)	1) Actual size (Letter) 2) Actual size (Legal)
ON	OFF	1) Actual size (Letter) 2) Memory reception (A4)	1) Actual size (Letter) 2) Memory reception (Legal)
ON	ON	1) Actual size (Letter) 2) Actual size (A4)	1) Actual size (Letter) 2) Actual size (Legal)

Reception image size: Legal

Cassette switches			
A	B	A4/Letter	Letter/Legal
OFF	OFF	1) Automatic reduction (A4) 2) Automatic reduction (Letter)	1) Actual size (Legal) 2) Automatic reduction (Letter)
OFF	ON	1) Automatic reduction (A4) 2) Automatic reduction (Letter)	1) Actual size (Legal) 2) Automatic reduction (Letter)
ON	OFF	1) Automatic reduction (A4) 2) Automatic reduction (Letter)	1) Actual size (Legal) 2) Automatic reduction (Letter)
ON	ON	1) Automatic reduction (A4) 2) Automatic reduction (Letter)	1) Actual size (Legal) 2) Automatic reduction (Letter)

3.4 Envelope Feeder EF-52

3.4.1 Service operations

a) External Views

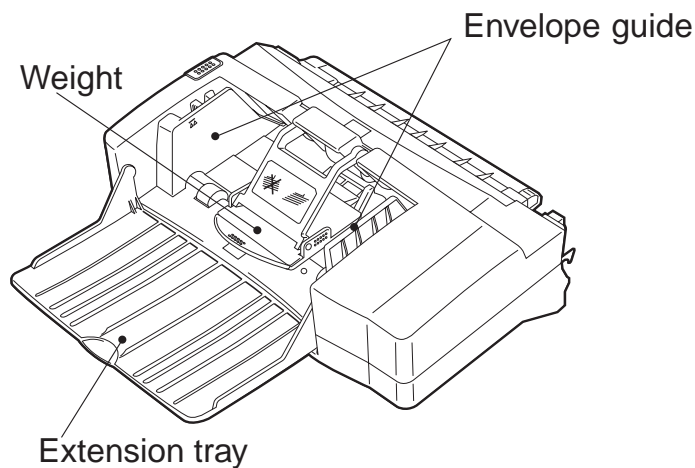

Figure 5-29 External View

b) Installation

b-1) Unpacking

Check that the box contains the envelope feeder.

b-2) Attachment to main unit

- (1) Open the envelope feeder packaging.
- (2) Take off the plastic bag and peel the tape off. Confirm that none of the covers were scratched or deformed during shipment.
- (3) Remove the packing materials from the envelope feeder.
- (4) Open the multi-purpose tray of the fax, remove the envelope entrance cover, and open the envelope feeder gear cover.
- (5) Holding the envelope feeder with both hands, install it into the fax.

3.4.2 Technical information

a) Configuration and construction

External structure

Item	Dimensions and weight
Dimensions	12.91" (W) × 13.94" (D) × 4.45" (H) (328 × 354 × 113 mm)
Weight	approx.4.85 lbs (2.2 kg)

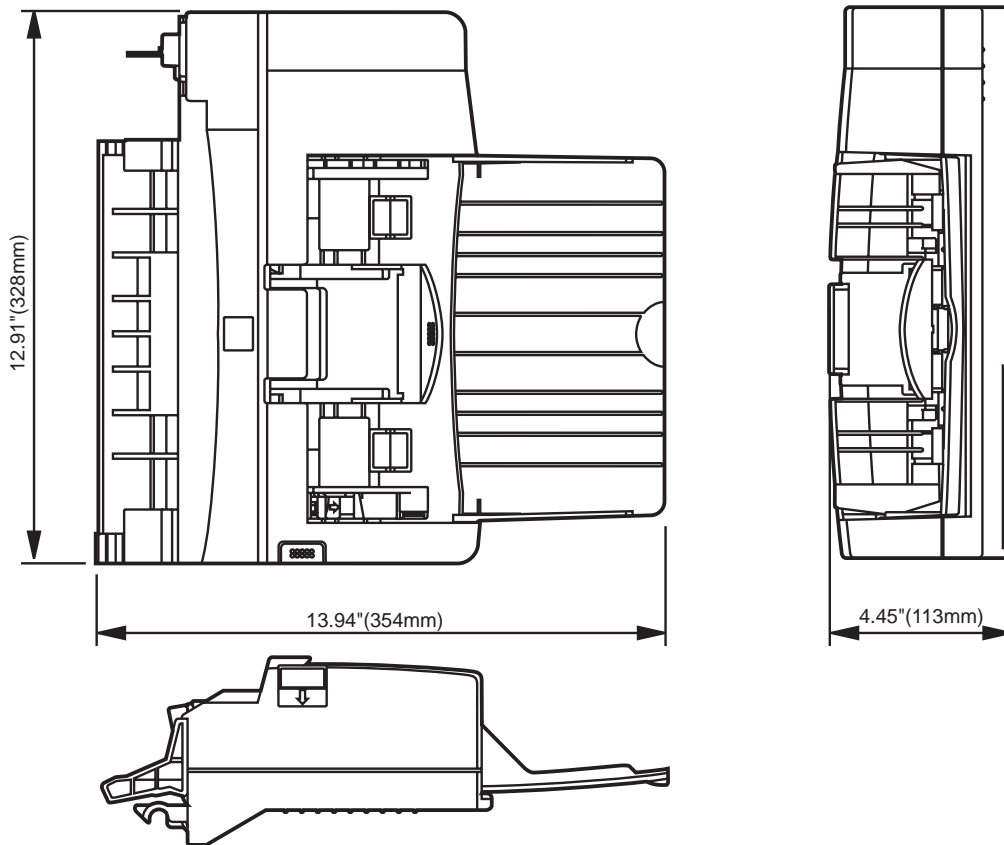

Figure 5-30 External View

b) Specifications

Envelope types

Monarch,COM-10,DL,B5,C5, recommended envelopes

Envelope size

3.54"(W) × 5.83"(L) (min.) ~ 7.01"(W) × 10.00"(L) (max.)
(90 × 148 mm ~ 178 × 254 mm)

Envelope feeder capacity

Max. 75 envelopes, or stacked to a height of 2.17"(55mm) Max.

3.4.3 Operation

a) Function

a-1) Paper pickup function

The pick-up roller, feed roller, and separation roller are rotated sequentially by the main motor rotation, and an envelope is picked up. Then, the unnecessary envelopes are removed by the separation roller and the picked up envelope is fed to the printer.

a-2) No paper detection function

The envelope sensor in the envelope feeder detects whether or not there is recording paper in the envelope feeder.

a-3) Paper jam detection

The CPU send retry instruction to the envelop feeder if the top of page sensor does not detect the leading edge of the envelope within the prescribed time after the pick-up starts.

b) Structures

The envelope feeder picks up the envelope from the envelope feeder and feeds it to the printer. The flow of the envelope is as shown below.

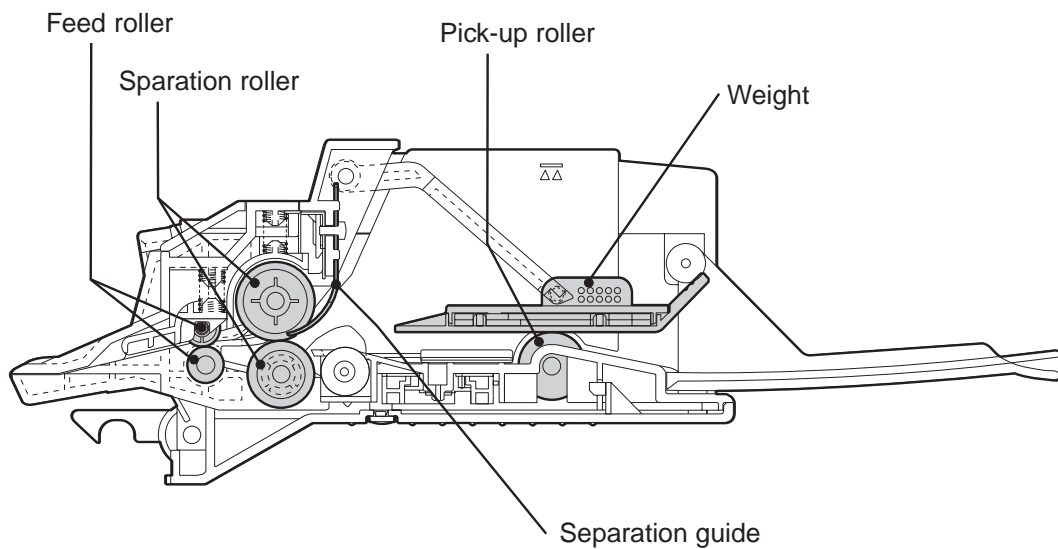

Figure 5-31 Envelope Feeder

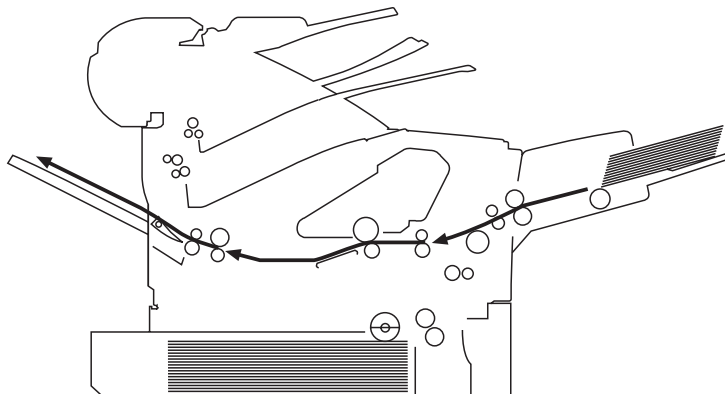

Figure 5-32 Cross-Sectional Diagram

c) Arrangement of sensors

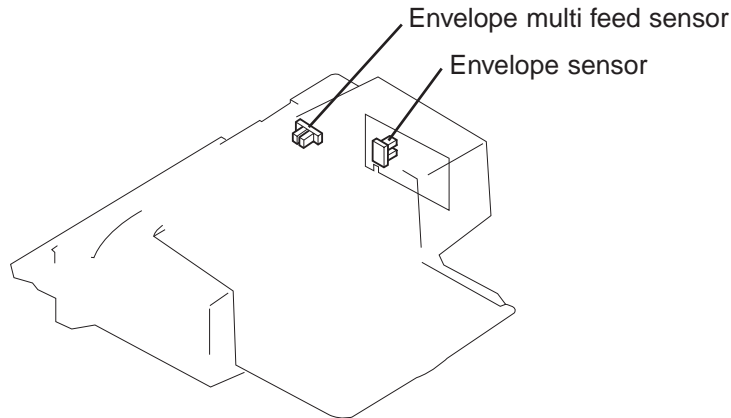

Figure 5-33 Arrangement of Sensors

d) Electrical circuit section

The signal detect by the envelope multiple feed sensor, envelope sensor and envelope pick-up solenoid, are sent ECNT board via the envelope feeder driver PCB.

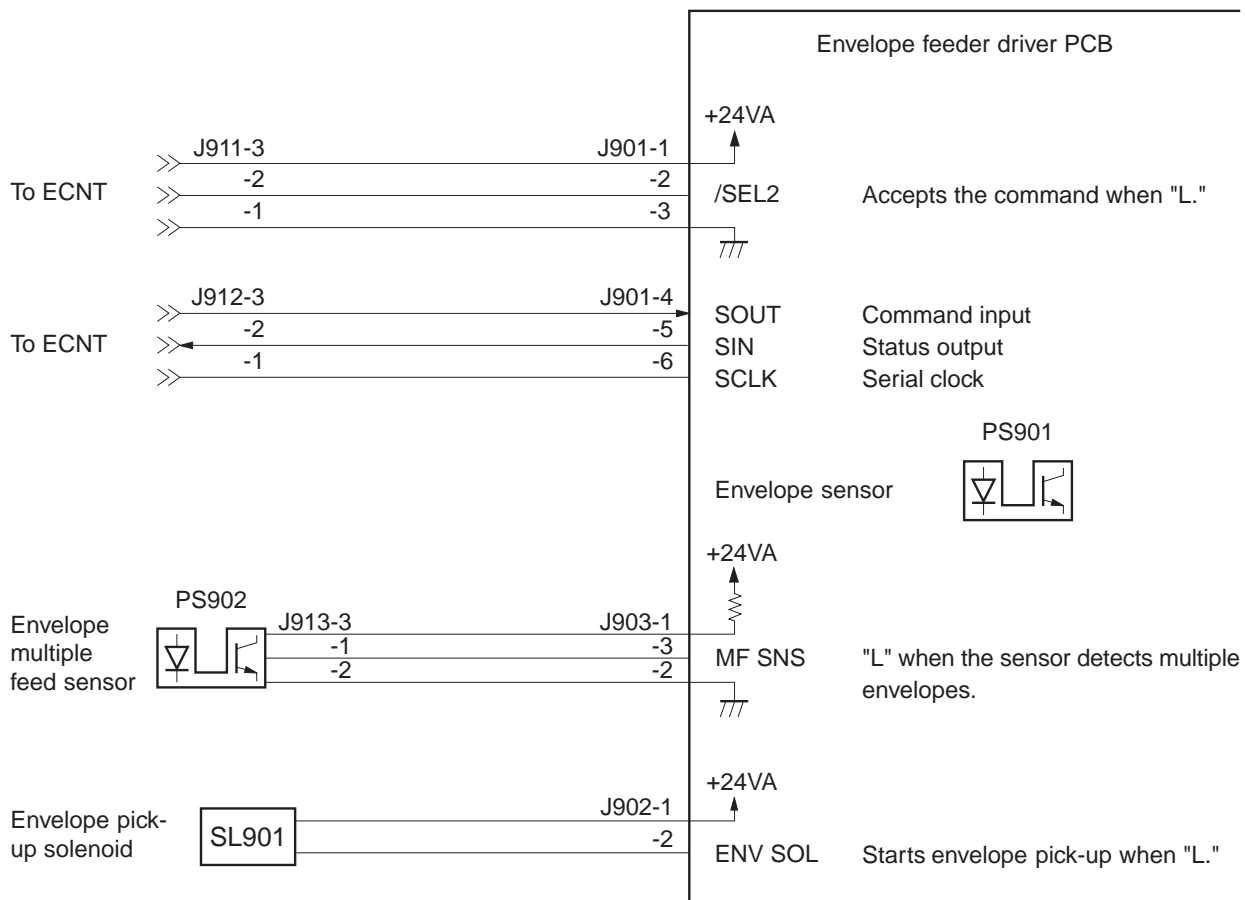

Figure 5-34 Electrical Circuit Section

3.4.4 Maintenance and service

a) Troubleshooting

a-1) Paper jam troubleshooting

<Possible causes>

1. Warped or twisted envelope

Action: Straighten the warped or twisted envelope, and then instruct the user.

2. Defective FAX-L1000 Printer kit

Action: Make a test print from the envelope feeder. If the envelope is picked up correctly, replace the FAX-L1000 Printer kit.

3. Dirty, worn or deformed envelope pickup roller

Action: Clean the pickup roller if dirty. Replace it if worn or deformed.

4. Damaged gears

Action: Check the gears of envelope feeder, and replace any damaged gears.

5. Defective envelope pickup solenoid

Action: Disconnect the envelope pickup solenoid connector J901 from the envelope feeder driver PCB. Measure the resistance between cable side connector J902-1 and J902-2. If it is not about 129 Ω , replace the envelope pickup solenoid.

6. Defective envelope feeder driver PCB

Action: Replace the envelope feeder driver PCB.

7. Defective ECNT board

Action: Replace the ECNT board.

8. Defective SCNT board

Action: Replace the SCNT board.

9. Defective TWINS board

Action: Replace the TWINS board.

10. Defective FAX-L1000 Printer kit

Action: Replace the FAX-L1000 Printer kit.

**a-2) Malfunction status troubleshooting
"5F-61 ERROR" (Envelope Option error)**

<Possible causes>

1. Defective envelope feeder connector

Action: Remove the envelope feeder from the fax and check the connector. Replace the connector if any failure is found.

2. Defective fax connector

Action: Check the connector. Replace the connector if any failure is found.

3. Defective envelope feeder driver PCB

Action: Replace the envelope feeder driver PCB.

4. Defective ECNT board

Action: Replace the ECNT board.

5. Defective SCNT board

Action: Replace the SCNT board.

6. Defective TWINS board

Action: Replace the TWINS board.

7. Defective FAX-L1000 Printer kit

Action: Replace the FAX-L1000 Printer kit.

"LOAD <SIZE> IN ENV." message appears when the specified sized envelope is in the envelope feeder.

<Possible causes>

1. Damaged envelope detection lever

Action: Replace the lever.

2. Defective envelope feeder driver PCB

Action: Replace the envelope feeder driver PCB.

3. Defective ECNT board

Action: Replace the ECNT board.

4. Defective SCNT board

Action: Replace the SCNT board.

5. Defective TWINS board

Action: Replace the TWINS board.

6. Defective FAX-L1000 Printer kit

Action: Replace the FAX-L1000 Printer kit.

b) Signal description

Envelope feeder(J901) ↔ ECNT board (J911)

J901	J911	Signal name	Description
—	4	N.C	Not connected
1	→ 3	+24V	Envelope feeder drive voltage
2	← 2	nSEL2	Envelope feeder select signal
3	— 1	DGND	Ground

Envelope feeder(J901) ↔ ECNT board (J912)

J901	J912	Signal name	Description
4	— 3	SOUT	Serial output data
5	← 2	SIN	Serial input data
6	→ 1	SCLOCK	Serial clock signal

Envelope feeder(J902) ↔ Envelope pick-up solenoid

J902	SOL	Signal name	Description
1	→ 1	+24V	Envelope pick-up solenoid drive voltage
2	→ 2	ENV SOL	Envelope pick-up solenoid drive signal

Envelope feeder(J903) ↔ Envelope multiple feed sensor

J903	SNS	Signal name	Description
1	→ 3	MF DR	Envelope multiple feed sensor drive
2	— 2	DGND	Ground
3	← 1	MF SNS	Envelope multiple feed detection signal

3.4.5 Installation Position Adjustment of Separation Guide of Envelope Feeder (adjustment of gap between separation guide and lower separation roller)

a) When

Normally, the separation guide and the top cover of the envelope feeder must be removed as one. However, if only the separation guide has been removed for unavoidable reason, or it needs to be replaced due to deformation, make the adjustment as shown below.

b) Tools

Tool	Use
1.6mm thickness gauge (RY9-0123)	Measuring gap between the separation guide and the lower separation roller

c) Adjustment

- (1) Install the separation guide.
- (2) Insert the 1.6mm thickness gauge (RY9-0123) between the separation guide and the lower separation roller.
- (3) Fix the separation guide with 1.6mm gap between the separation guide and the lower separation roller.

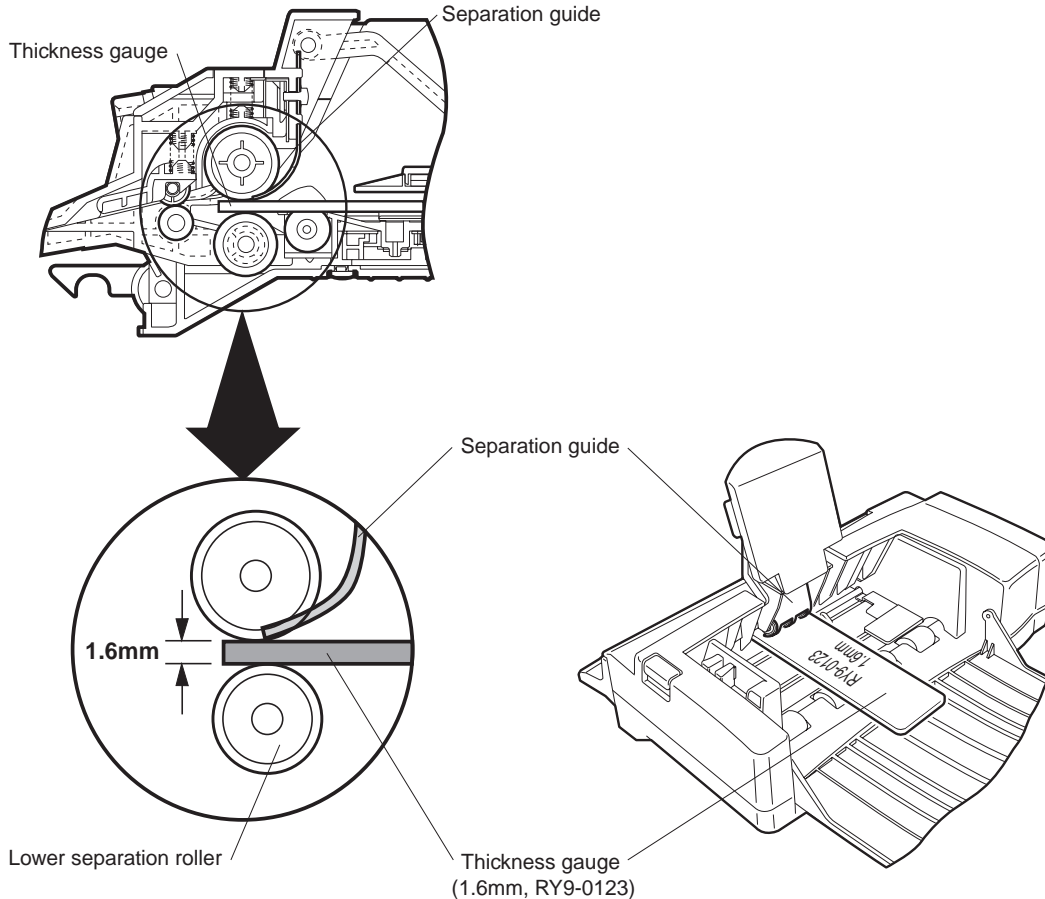

Figure 5-35 Adjustment of Separation Guide

3.4.6 Installation Position Adjustment of Envelope Multiple Feed Sensor

a) When

The installation position of envelope multiple feed sensor is normally adjusted at the factory. However, if the screw which hold the sensor is removed or accidentally loosened for replacement of the sensor or its peripheral parts, the installation position of envelope multiple feed sensor must be adjusted correctly.

The adjustment procedures are shown below.

b) Tools

Tool	Use
Phillips screwdriver	Adjusting gap between the upper and lower feed rollers
0.7mm thickness gauge (RY9-0122)	Adjusting gap between the upper and lower feed rollers
Printer driver tester (RY9-0124)	Checking operation of the envelop multiple feed sensor

c) Adjustment

c-1) Preparations

- (1) Remove the top cover of the envelop feeder.

c-2) Adjustment

- (1) Disconnect the power cord.
- (2) Connect the two connectors of the printer driver tester with the printer and the envelop multiple feed sensor connector as shown below.
- (3) Insert the 0.7mm thickness gauge (RY9-0122) between the upper and lower feed rollers of the envelope feeder from the side where the envelope is to be set.
- (4) Connect the power cord.
- (5) The Sensor Test LED of the printer driver tester lights up.
- (6) Tighten the screw that holds the sensor until the LED goes off.

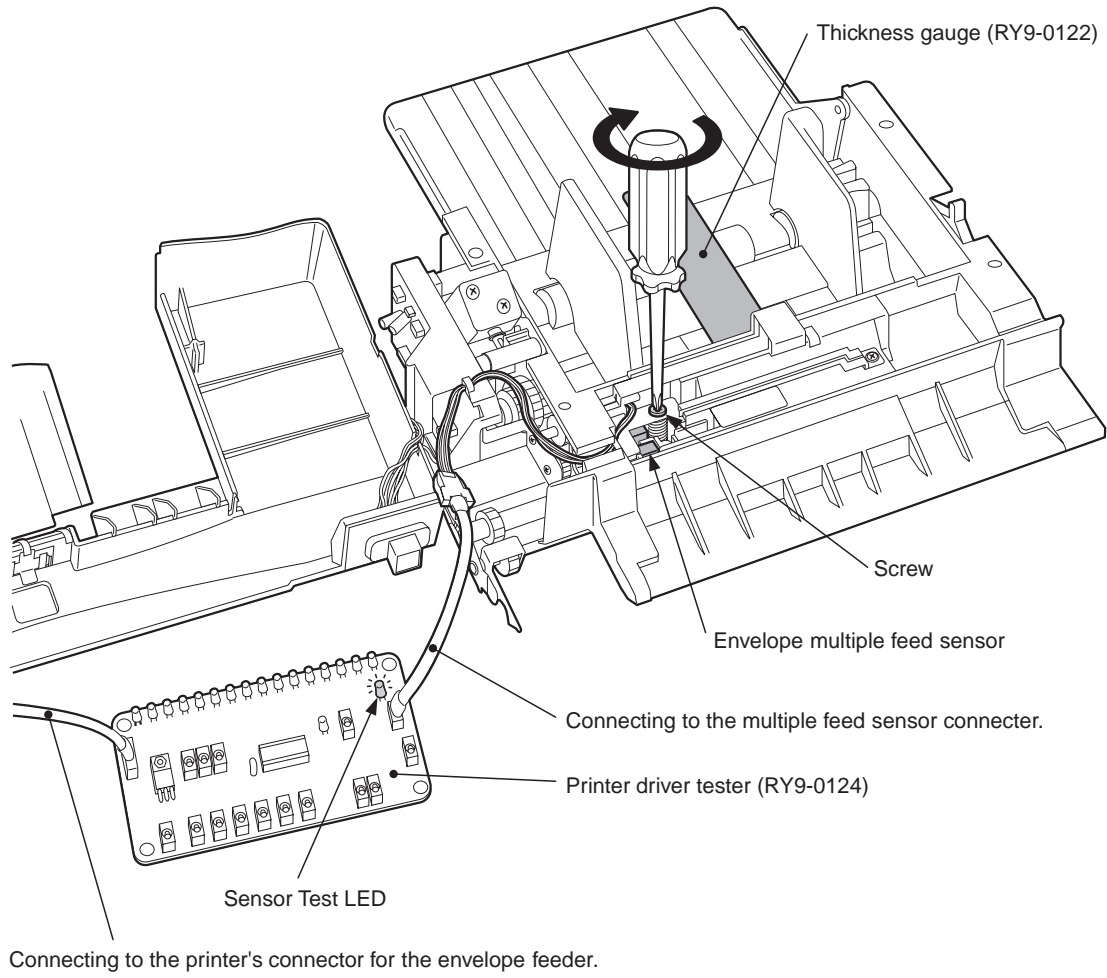

Figure 5-36 Adjustment of Envelope Multiple Feed Sensor

3.5 Duplex Unit DU-52
3.5.1 Service operations
a) External Views

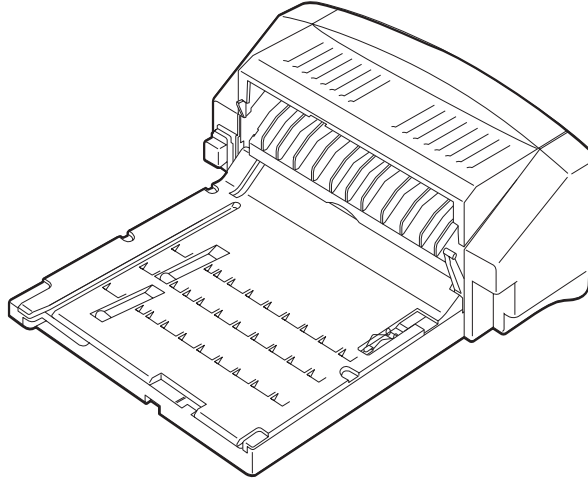

Figure 5-37 External View

b) Installation

b-1) Unpacking

Check that the box contains the duplexing feeder.

b-2) Attachment to main unit

- (1) Open the duplexing unit packaging.
- (2) Take off the plastic bag and peel the tape off. Confirm that none of the covers were scratched or deformed during shipment.
- (3) Remove the packing materials from the duplexing unit.
- (4) Remove the 2 duplexing unit slot covers from the fax.
- (5) Holding the duplexing unit with both hands, install it into the fax.

3.5.2 Technical information

a) Configuration and construction

External structure

Item	Dimensions and weight
Dimensions	12.56" (W) × 14.17" (D) × 5.55" (H) (319 × 360 × 141 mm)
Weight	approx. 7.72 lbs (3.5 kg)

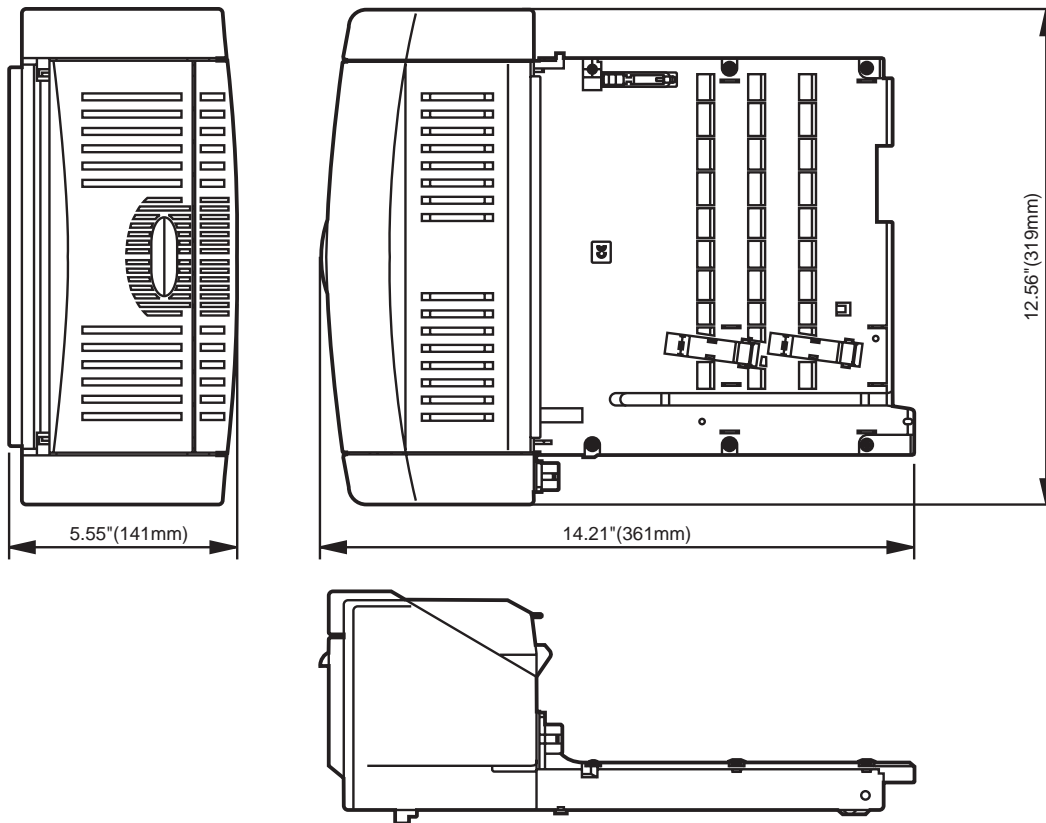

figure 5-38 External View

b) Specifications

Paper dimensions

Letter, Legal, Executive, A4, and B5-JIS sizes plain paper (60g/m² ~ 105g/m² recommended paper)

3.5.3 Operation

a) Function

a-1) Reversing function

When the duplexing unit receives the duplexing unit command from the fax, it turns ON the duplexing unit solenoid, moves the face-up deflector and feeds the paper to the duplexing unit. It also rotates the reversing motor in the reverse direction for about 1 second, and feeds the paper remaining in the reversing unit to the duplexing unit pick-up sensor.

About 0.3 seconds (about 0.5 seconds for 1200dpi print) after the paper reaches the reversed paper sensor, the duplexing unit driver rotates the reversing motor in the normal direction, and feeds the paper to the reversing wait position (where the paper reaches about 0.2 seconds after the leading edge of the paper passes the reversed paper sensor).

If the duplexing unit pick-up sensor does not detect the preceding paper, the duplexing unit driver rotates the reversing motor in the reverse direction and the duplex feed motor in the normal direction in order to feed the paper to the duplex pick-up wait position (where the paper reaches about 0.4 seconds after the leading edge of the paper passes the duplexing unit pick-up sensor) at high speed.

If the duplexing unit pick-up sensor detects the preceding paper, the duplexing unit holds the paper at the duplexing unit pick-up wait position until the preceding paper passes the sensor.

a-2) Duplexing unit pick-up function

When the /PRNT signal is sent to the ECNT board from the video controller, the main motor of the printer starts rotation. When the main motor rotation reaches its prescribed speed, the engine controller turns ON the feed roller clutch of the printer and sends the duplexing unit pick-up command to the duplexing unit driver.

When the duplexing unit driver receives the duplexing unit pick-up command from the fax, it rotates the duplex feed motor in the reverse direction to feed the paper from the duplexing unit pick-up wait position to the pre-feeder sensor of the printer at the same speed as the print speed of the fax.

The ECNT board detects the conditions of the pre-feed sensor for a prescribed period of time after the duplexing unit pick-up starts. If the pre-feed sensor does not detect no paper within the prescribed period of time, the ECNT board turns OFF the feed roller clutch and sends the feed stop command to the duplexing unit driver to stop feeding the paper in the prescribed period of time after the top of page sensor detects the paper present condition of the preceding paper. When the top of page sensor detects the trailing edge of the preceding paper, the CPU resumes feeding the stopped paper. By this, the between-page distance appropriate for the continuous printing is achieved.

The paper then reaches the registration arm where its skew is corrected, goes through transfer, separation, fixing and delivery unit and is delivered to the tray.

a-3) Paper jam detection

The following paper sensors are installed to detect whether the paper is present or not and whether the paper is fed normally or not.

- Reversed paper sensor (PS703)
- Duplexing unit pick-up sensor (PS701)

The CPU determines whether paper is jammed or not by checking whether paper is present or absent at the sensors at check timing stored in the memory.

If the CPU determines that a jam has occurred, it stops duplex feeding and notifies the jam occurrence to the engine controller.

b) Structure

The paper is led to the duplexing unit by the face-up deflector. This face-up deflector moves in conjunction with the face-up tray, however, it moves by the duplexing unit solenoid (SL701) when the face-up tray is closed.

The reversing roller changes the feeding direction of the paper fed to the duplexing unit. The paper is then transported by the oblique roller and feed roller so that its edge contacts with the left panel to correct its skew, and is sent to the fax.

The duplexing unit has two motors; reversing motor (M701) and duplex feed motor (M702). They are stepping motors. The rotating directions (clockwise and counterclockwise) of the motors are controlled by the duplexing unit driver.

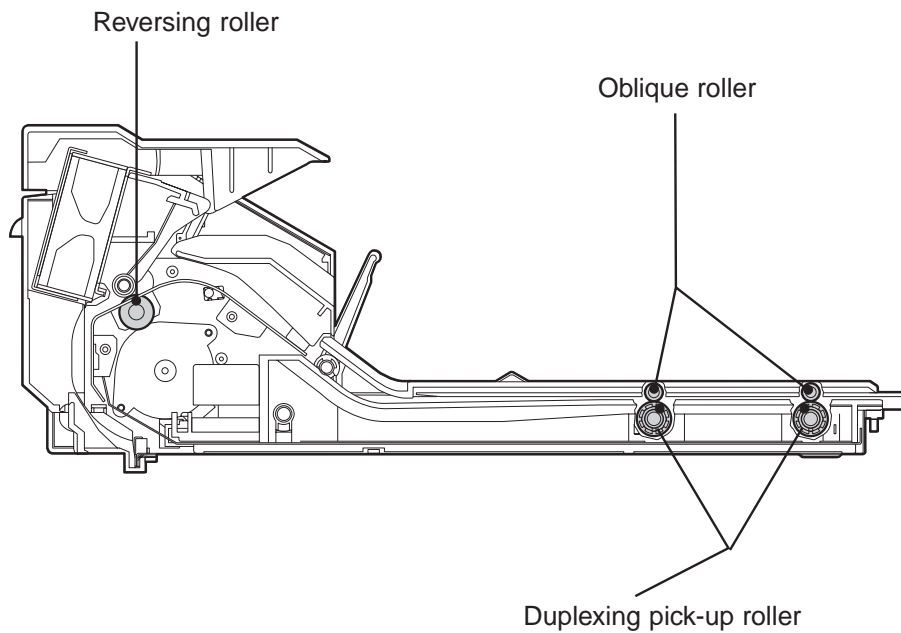

Figure 5-39 Duplexing Unit

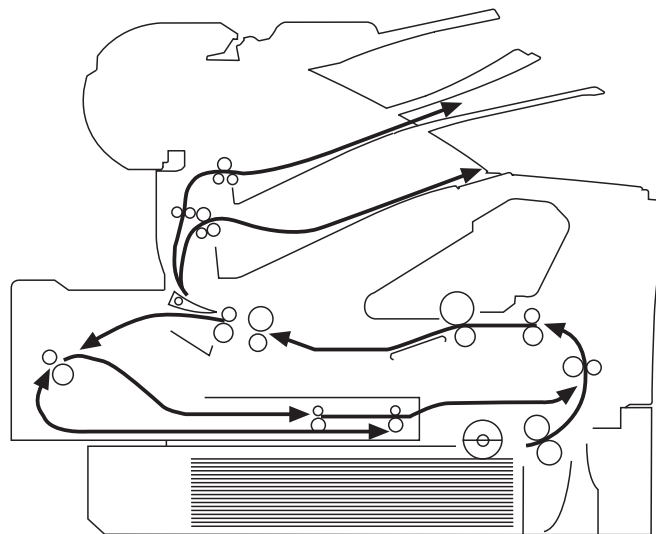

Figure 5-40 Cross-Sectional Diagram

c) Arrangement of sensors

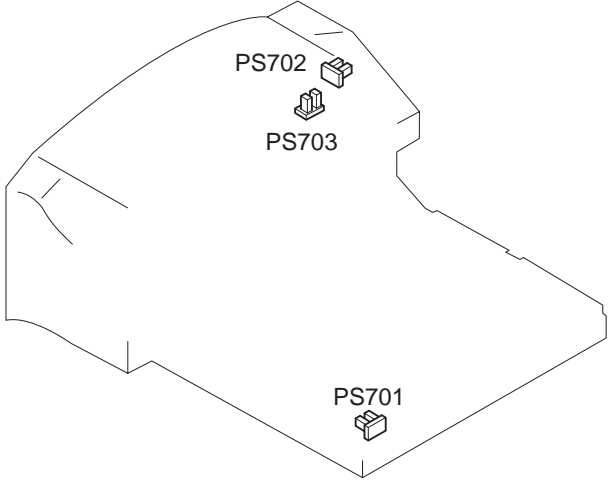

Figure 5-41 Arrangement of Sensors

d) Electrical circuit section

The signal detect by the duplexing unit pick-up sensor, face-up sensor and reversed paper sensor, are sent ECNT board via the duplexing unit driver PCB.

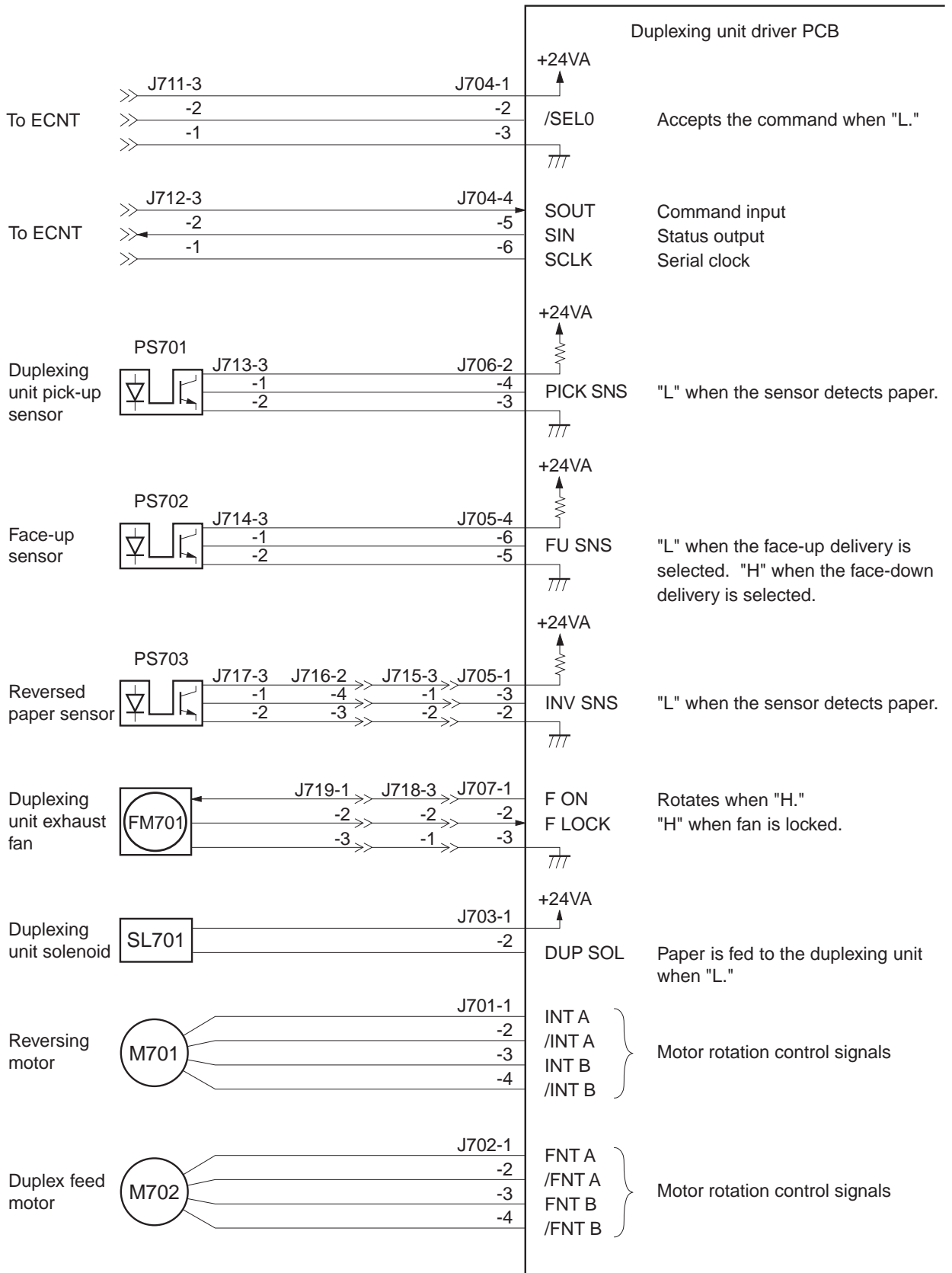

Figure 5-42 Electrical Circuit Section

3.5.4 Maintenance and service

a) Troubleshooting

a-1) Paper jam troubleshooting

<Possible causes>

1. Paper is curled due to having been left for a long time.

Action: Straighten the paper, and then instruct the user.

2. Paper not suitable for duplex printing was used.

Action: Instruct the user to use the paper suitable for duplex printing.

3. Foreign materials or burrs are present on the feed guide.

Action: Remove the foreign materials. Replace the guide if it has burrs.

4. Worn or deformed rollers

Action: Replace worn or deformed rollers.

5. Paper dust or dirt on the rollers.

Action: Remove the paper dust and dirt.

6. Duplexing unit solenoid lever does not move smoothly, or is damaged.

Action: Adjust the lever so that it moves smoothly. Replace it if damaged.

7. Damaged or worn gears

Action: Replace any damaged or worn gear(s).

8. Sensor levers do not move smoothly, or are damaged.

Action: Adjust the levers so that they move smoothly. Replace them if damaged.

9. Defective motor

Action: Replace the motor.

10. Defective duplexing unit driver PCB

Action: Replace the duplexing unit driver PCB.

11. Defective ECNT board

Action: Replace the ECNT board.

12. Defective SCNT board

Action: Replace the SCNT board.

13. Defective TWINS board

Action: Replace the TWINS board.

14. Defective FAX-L1000 Printer kit

Action: Replace the FAX-L1000 Printer kit.

a-2) Malfunction status troubleshooting

"5F-56 ERROR" (Duplexing unit exhaust fan (FM701) malfunction)

<Possible causes>

1. Poor contact in the connectors of the FM701 drive signal line

Action: Reconnect the intermediate connectors J718 and J719, then the duplexing unit driver PCB connector J707.

2. Defective fan motor

Action: Replace the exhaust fan.

3. Defective duplexing unit driver PCB

Action: Replace the duplexing unit driver PCB.

"5F-60 ERROR" (Duplex Option error)

<Possible causes>

1. Defective duplexing unit connector

Action: Remove the duplexing unit from the fax and check the connector. Replace the connector if any failure is found.

2. Defective fax connector

Action: Check the connector. Replace the connector if any failure is found.

3. Defective duplexing unit driver PCB

Action: Replace the duplexing unit driver PCB.

4. Defective ECNT board

Action: Replace the ECNT board.

5. Defective SCNT board

Action: Replace the SCNT board.

6. Defective TWINS board

Action: Replace the TWINS board.

7. Defective FAX-L1000 Printer kit

Action: Replace the FAX-L1000 Printer kit.

"DUPLEX JAM" message appears when the paper jam has not occurred; so, the fax cannot be in READY mode.

<Possible causes>

1. Reversing paper sensor lever does not move smoothly, or is damaged.
Action: Set the lever to move smoothly. Replace it if damaged.

2. Duplexing unit pick-up paper sensor lever does not move smoothly, or is damaged.
Action: Set the lever to move smoothly. Replace it if damaged.

3. Defective reversing paper sensor
Action: Replace the sensor.

4. Defective duplexing unit pick-up paper sensor 1
Action: Replace the sensor.

5. Defective duplexing unit driver PCB
Action: Replace the duplexing unit driver PCB.

6. Defective ECNT board
Action: Replace the ECNT board.

7. Defective SCNT board
Action: Replace the SCNT board.

8. Defective TWINS board
Action: Replace the TWINS board.

9. Defective FAX-L1000 Printer kit
Action: Replace the FAX-L1000 Printer kit.

b) Signal description

Duplexing unit(J701) ←→ Reversing motor

J701		Motor	Signal name	Description
1	→	1	IMT A	Reversing motor drive signal
2	→	2	nIMT A	Reversing motor drive signal
3	→	3	IMT B	Reversing motor drive signal
4	→	4	nIMT B	Reversing motor drive signal

Duplexing unit(J702) ↔ Duplex feed motor

J701	Motor	Signal name	Description
1	→ 1	FMT A	Duplex feed motor drive signal
2	→ 2	nFMT A	Duplex feed motor drive signal
3	→ 3	FMT B	Duplex feed motor drive signal
4	→ 4	nFMT B	Duplex feed motor drive signal

Duplexing unit(J703) ↔ Duplex unit solenoid

J703	Soleniod	Signal name	Description
1	→ 1	+24V	Duplexing unit solenoid drive voltage
2	→ 2	DUP SOL	Duplexing unit solenoid drive signal

Duplexing unit(J704) ↔ ECNT board(J71)

J704	J71	Signal name	Description
1	→ 6	+24V	Duplexing unit drive voltage
2	← 5	nSELO	Duplexing unit select signal
3	— 4	DGND	Ground
4	← 3	SOUT	Serial input data
5	→ 2	SIN	Serial output data
6	→ 1	SCLK	Serial clock signal

Duplexing unit(J705) ↔ Reversed paper sensor

J705	Sensor	Signal name	Description
—	— 4	N.C	Not connected
1	→ 3	INV DR	Reversed paper sensor drive
2	— 2	DGND	Ground
3	← 1	INV SNS	Reversed paper detection signal

Duplexing unit(J705) ↔ Face-up sensor

J705	Sensor	Signal name	Description
4	→ 3	FU DR	Face-up sensor drive
5	— 2	DGND	Ground
6	← 1	FU SNS	Face-up detection signal

Duplexing unit(J706) ↔ Duplexing unit pick-up sensor

J706	Sensor	Signal name	Description
1	— —	N.C	Not connected
2	→ 3	PICK DR	Duplex pick-up drive
3	— 2	DGND	Ground
4	← 1	PICK SNS	Duplex pick-up detection signal

Duplexing unit(J707) ↔ Duplexing unit exhaust fan

J707		Fan	Signal name	Description
1	→	1	F ON	Duplexing unit fan drive signal
2	←	2	F LOCK	Duplexing unit fan lock detection signal
3	—	3	DGND	Ground

3.6 FAX-L1000 ISDN Kit

3.6.1 Safety and precautions

Damage due to electrostatic discharge

Electrostatic charge in the human body is the cause of damage to electronic parts as well as changes in their characteristics. When attaching / removing the kit, be sure to take measures against electrostatic discharge by using a wrist strap, etc. If the kit is handled when an electrostatic charge is present, the electronic parts may be damaged.



REFERENCE

Countermeasures for Electrostatic Discharge

For details regarding countermeasures for electrostatic discharge, please refer to *Chapter 1, 2.3.1 Damage due to electrostatic discharge*.

3.6.2 Service operations

a) External view

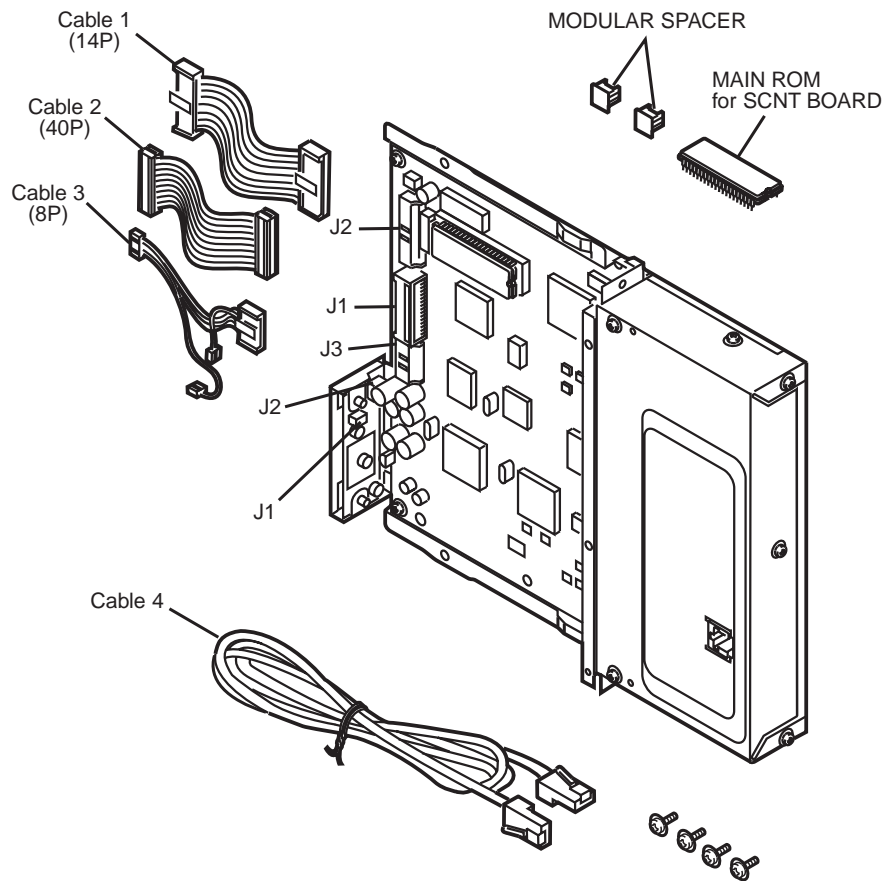

Figure 5-43 External View

b) Installation

b-1) Unpacking

Check that the box contains the FAX-L1000 ISDN Kit, cables, ROM, modular spacers and four screws.

b-2) Preparation

Perform the operations below before attaching the kit.

- (1) Disconnect the modular jack cord (telephone line) from the fax.
- (2) Disconnect the power cord of the fax unit at the power source. Wait at least 10 minutes for the power supply unit to cool before continuing to work.
- (3) If a FAX-L1000 Printer kit (Option) or an FAX-L1000 Network Printer Upgrade Kit (Option) is installed, disconnect the IEEE 1284 compliant parallel interface cable or the network cable from the options.
- (4) Remove the one screw.
- (5) Slide the right cover to the right, open the top side, and pull up to remove.

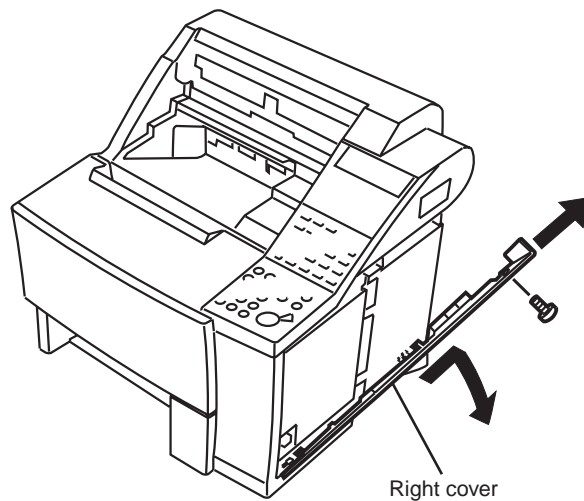

Figure 5-44 Preparations for Installation 1

- (6) Refer to Figure 5-43 and bend cables 1 and 2 as shown in order to make insertion of the kit easier.
- (7) Insert cables 1 and 2 into J2 and J1 on the G4 board ass'y.
- (8) Insert the connectors of cable 3 into J1 and J2 on the G4 relay board unit. Then Insert the other connector into J3 on the G4 board ass'y.

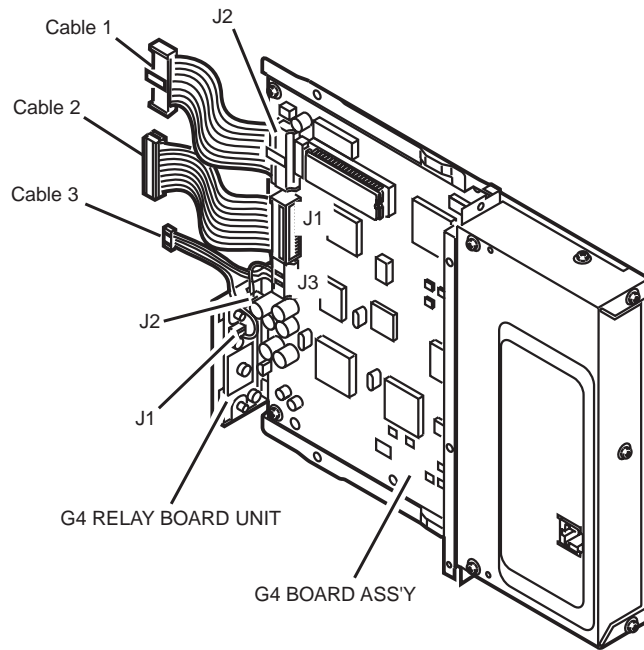

Figure 5-45 Preparation for Installation 2

If a FAX-L1000 Printer kit (Option) is installed proceed to step (10).

- (9) Remove the six screws and remove the shield cover.

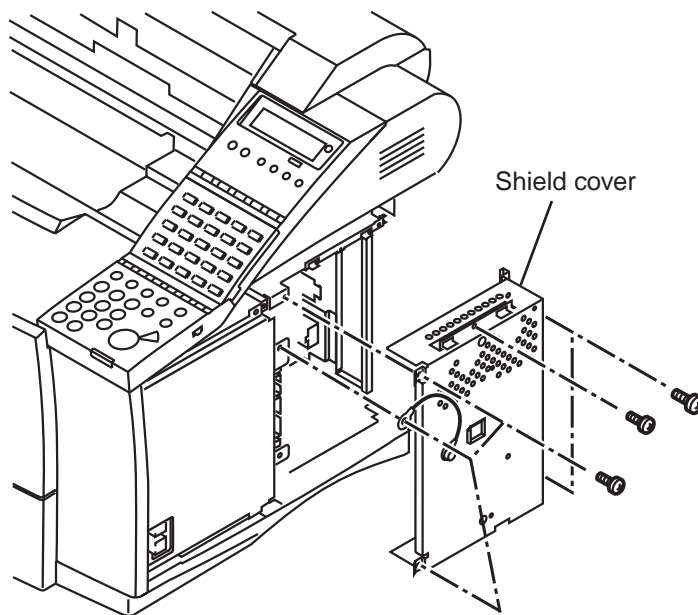

Figure 5-46 Preparation for Installation 3A

- (10) Remove the seven screws.
- (11) Disconnect the connectors of the option from J33, J34, J35 and J40 on the TWINS board. Then, remove the option.

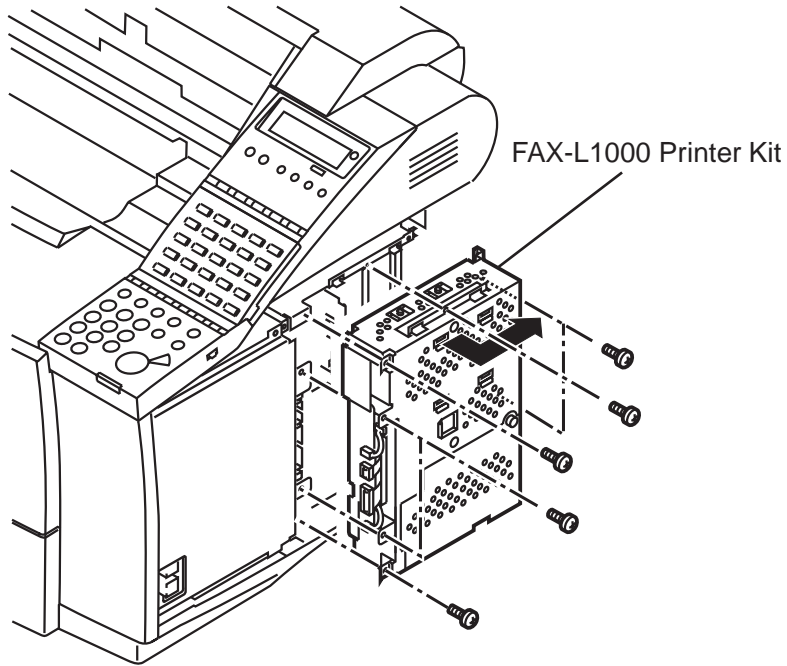

Figure 5-47 Preparation for Installation 3B

- (12) Remove the two screws and remove the shield cover 2.

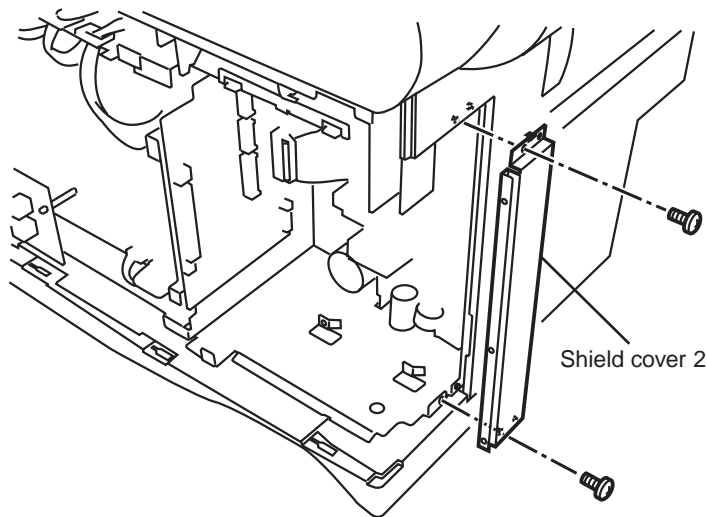

Figure 5-48 Preparation for Installation 4

b-3) Attaching the kit

- (1) Insert the kit, aligning the tabs with the slots on the main unit.
- (2) After inserting the kit, insert cables 1, 2 and 3 into J37, J39 and J43 on the TWINS board.
- (3) Fasten the kit in place with the 4 included screws.

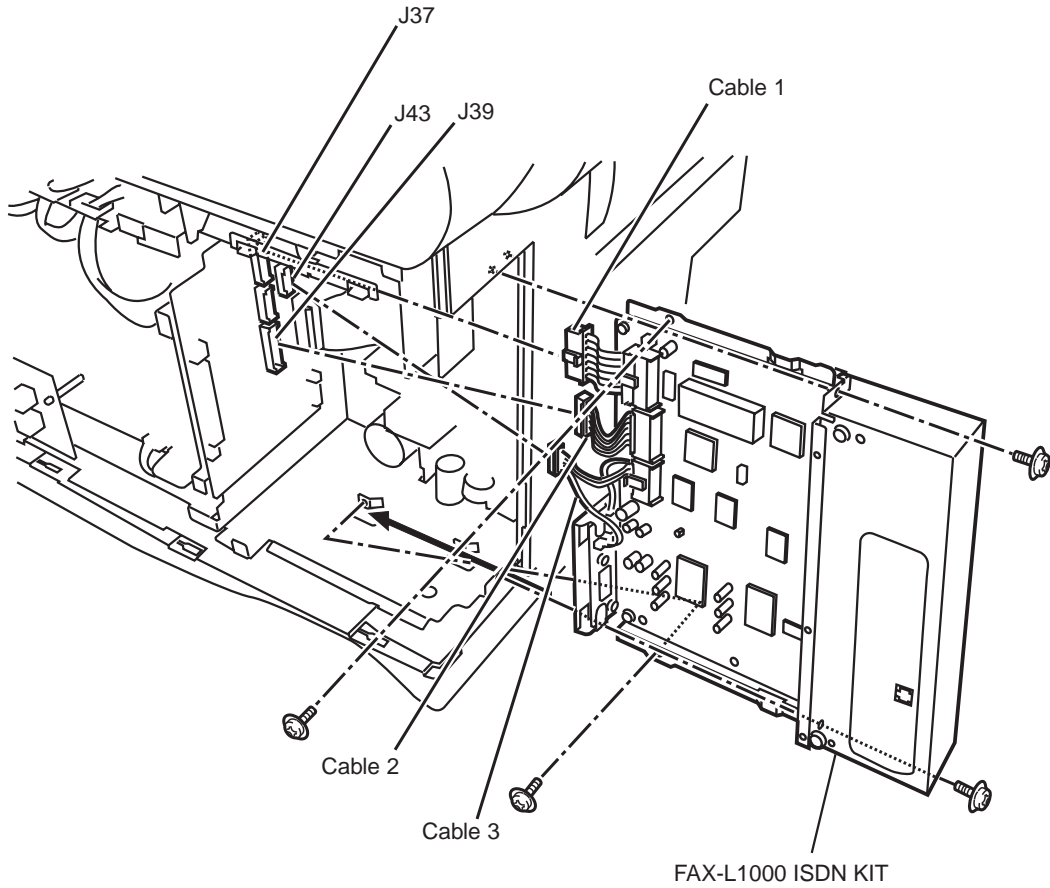

Figure 5-49 FAX-L1000 ISDN Kit Installation

If a FAX-L1000 Printer Kit (Option) is installed proceed to step (5).

- (4) Fasten the shield cover in place with the six screws.
- (5) Insert FAX-L1000 Printer kit (Option) into the main unit. Attach the option by aligning it with the hooks in the circles in the figure and sliding it in the direction indicated by the black arrow.
- (6) After inserting the option, insert cables of the option into J33, J34, J35 and J40 on the TWINS board.
- (7) Fasten the option in place with the seven screws.

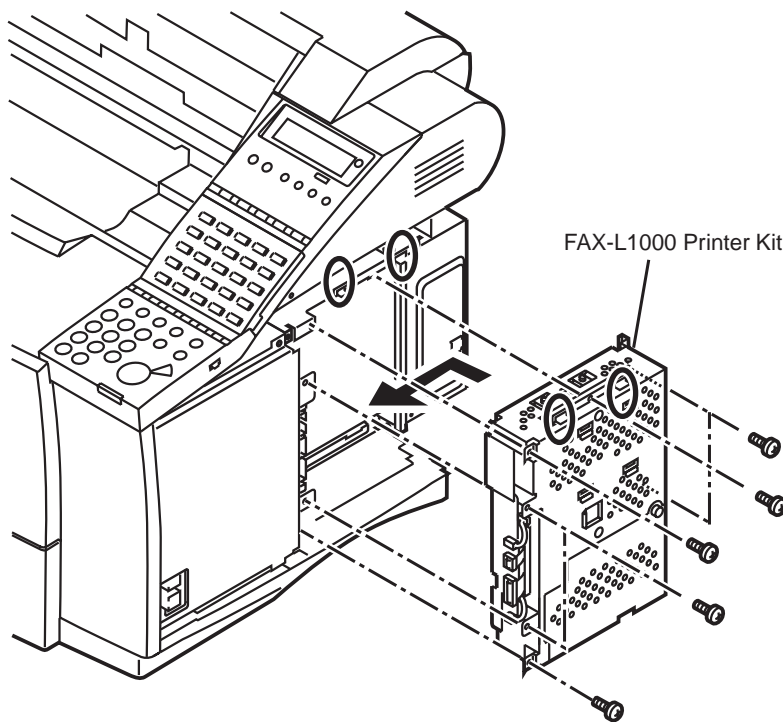

Figure 5-50 FAX-L1000 Printer Kit (Option) Installation

b-4) Replacing the ROM

- (1) Remove the six screws and remove the shield cover.

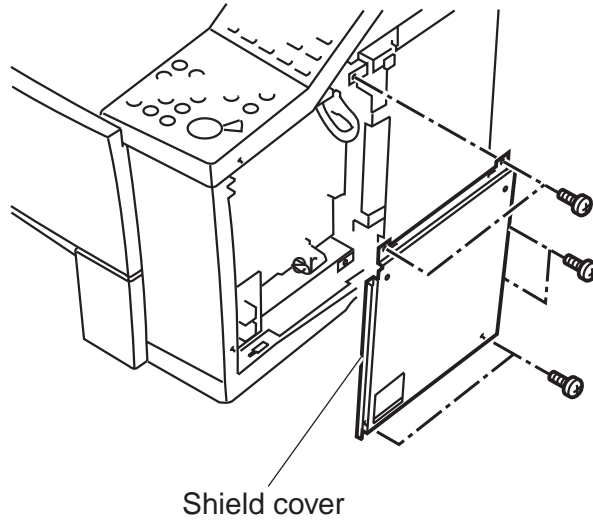

Figure 5-51 ROM Replacement 1

- (2) Remove the ROM on the SCNT board using the IC-Removing Tool (HY9-0022).
- (3) Replace the ROM.

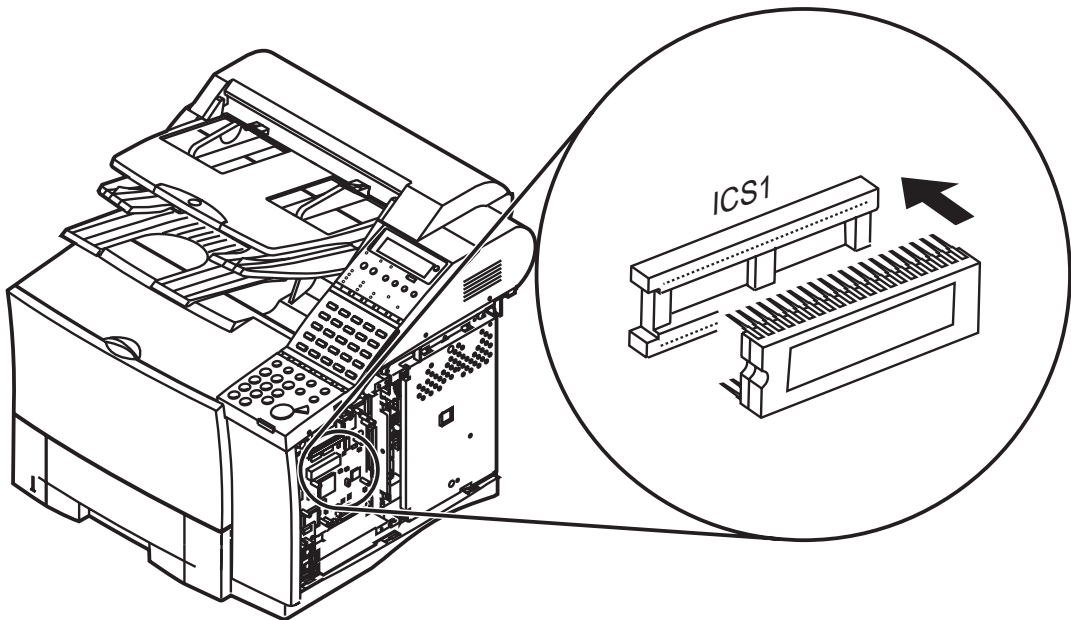

Figure 5-52 ROM Replacement 2

- (4) Fasten the shield cover of the SCNT board in place with the six screws.
- (5) Fasten the right cover in place with the one screw.
- (6) Attach the modular spacers into the extension phone jack and telephone line jack.
- (7) Connect the ISDN cable (Cable 4) to the ISDN line jack marked "ISDN" on the kit. Then connect the other end of the cable to the wall ISDN line jack.
- (8) If a FAX-L1000 Printer kit (Option) or an FAX-L1000 Network Printer Upgrade Kit (Option) is installed, connect the IEEE 1284 compliant parallel interface cable or the network cable to the options.
- (9) Plug in the fax.

b-5) All clear operation

- (10) Perform the All clear operation.

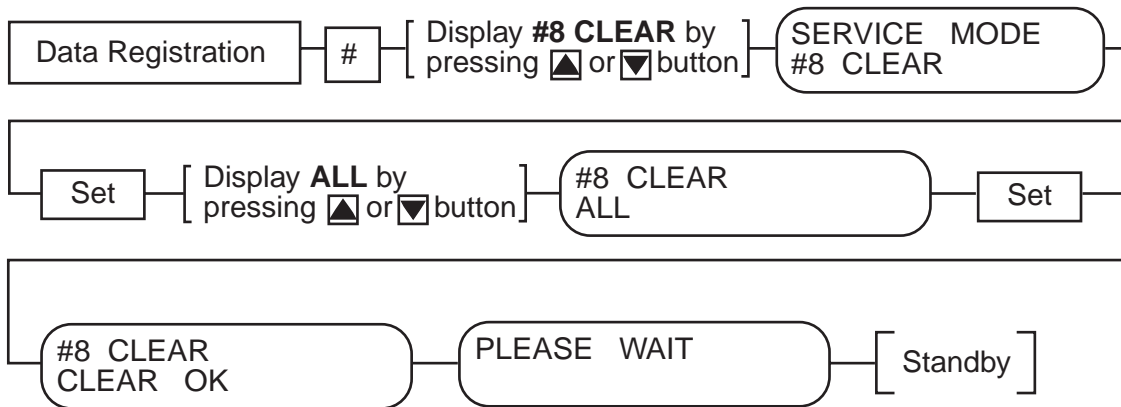

Figure 5-53 All Clear Operation



While waiting to return to the ready state after executing "All clear", please do not press the Stop button. Doing so may cause a malfunction afterwards.

b-6) Check after the Kit Installation

After installing the kit, carry out the following procedure to ensure that the kit is properly identified by the main unit.

- (1) Referring to the flow chart, enter service data registration, then check that the ROM versions are displayed.

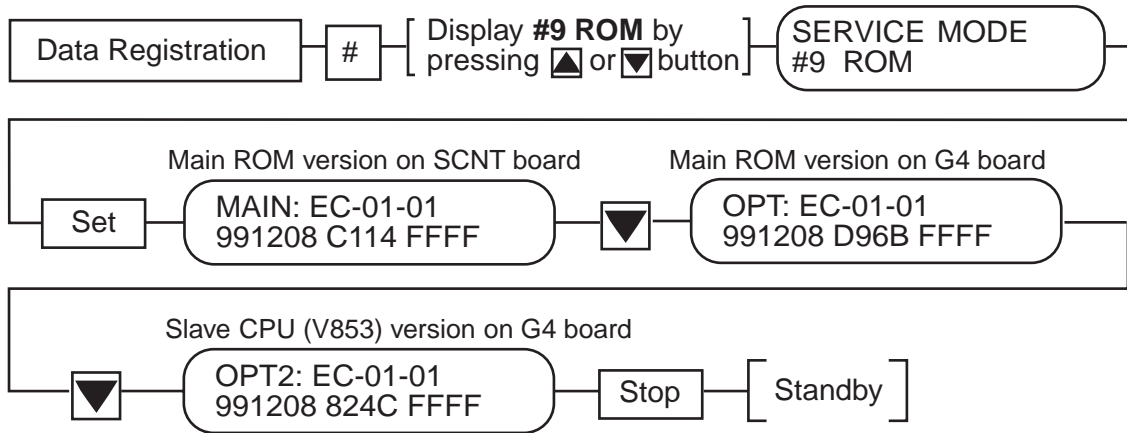

Figure 5-54 ROM Version Check

- (2) After confirming this, push the Stop button, which will put the machine into a standby condition.
- (3) If the ROM versions are not displayed, return to *b-3) Attaching the kit* or *b-4) Replacing the ROM*, re-attach the kit or the ROM, and then re-check the display.
- (4) Perform a communications test to make sure that transmission and reception are normal.
- (5) If a problem occurs during the test, perform the following:
 - Check that the ISDN cable is securely connected.
 - Check that the kit is securely connected.
 - Refer to the *Service Manual, Chapter 5, 3.6.7 Maintenance and service*.

b-7) Removing the kit

When removing the kit or the ROM, perform the steps in *b-3) Attaching the kit* or *b-4) Replacing the ROM*, in reverse order. Be sure to remove them only after turning the power off.

3.6.3 Technical information

a) Configuration and construction

1. Product names FAX-L1000 ISDN KIT

2. External view

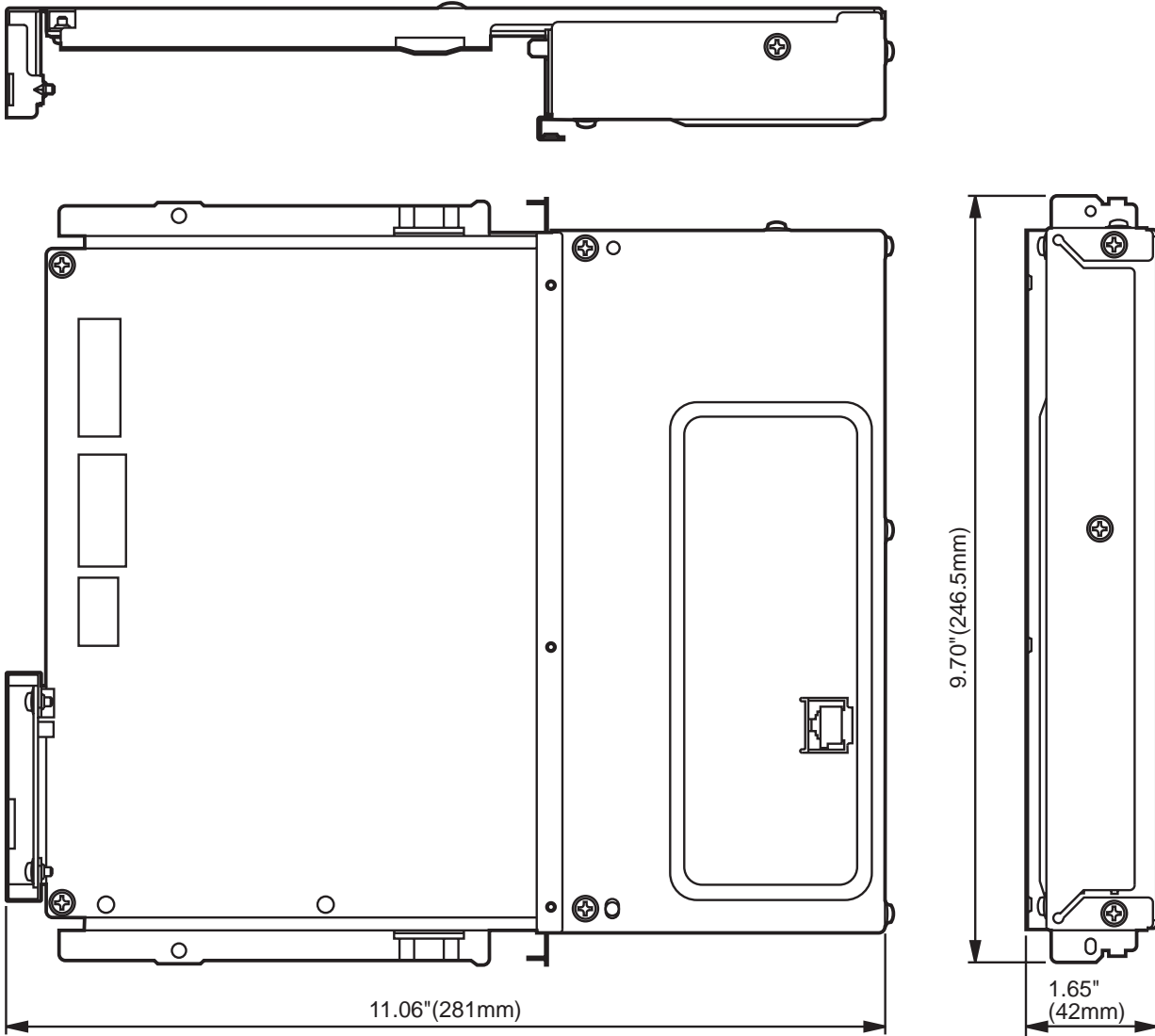

Figure 5-55 External View

b) Specifications

Dimensions

11.06" (W) × 9.70" (D) × 1.65" (H) (281mm × 246.5mm × 42mm)

Weight

Approx. 2.20 lbs (1.0 kg)

Applicable lines

Euro-ISDN

Communication method

Half-duplex

Communication control protocol

ITU-T T.62

Modulation method

G3 image signals	ITU-T V.27ter (2.4k, 4.8k bps) ITU-T V.29 (7.2k, 9.6k bps) ITU-T V.17 (14.4kbps, 12kbps, TC9.6kbps, TC7.2kbps) ITU-T V.34 (2.4kbps, 4.8kbps, 7.2kbps, 9.6kbps, 12kbps, 14.4kbps, 16.8kbps, 19.2kbps, 21.6kbps, 24kbps, 26.4kbps, 28.8kbps, 31.2kbps, 33.6kbps)
G3 procedure signals	ITU-T V.21 (No.2) 300bps ITU-T V.8, V.34 300bps, 600bps, 1200bps

Transmission speed

G3	33.6kbps, 31.2kbps, 28.8kbps, 26.4kbps, 24kbps, 21.6kbps, 19.2kbps, 16.8kbps, 14.4kbps, 12kbps, TC9.6kbps, TC7.2kbps, 9.6kbps, 7.2kbps, 4.8kbps, 2.4kbps With automatic fallback function
G4	64k bps With automatic fallback function

Coding

G3	MH, MR, MMR, JBIG
G4	MMR, JBIG

Error correction

ITU-T ECM

Transmission time*

approx. 3sec.

*Based on Canon FAX Standard Chart No.1, A4, standard mode

Time required for transmission protocol

Mode	Pre-message Protocol *1	Post-message Protocol *2 (between pages)	Post-message Protocol *3 (after pages)
G4	Approx. 1.1 s	Approx. 1 s	Approx. 0.6 s

*1 Time from when other facsimile is connected to the line until image transmission begins.

*2 Post-message (between pages): Time from after one document has been sent until transmission of the next document starts if several pages are transmitted.

*3 Post-message (after last pages): Time from after image transmission is completed until line is switched from facsimile to telephone.

Transmission output level

from -8 to -15 dBm

Minimum receive input level

-43 dBm

Modem IC

CONEXANT (formerly Rockwell) R288F

**c) Service soft switch
#4C ISDN (ISDN settings)**

ISDN BASIC Bitswitch SW01

Bit	Function	1	0
0	Not used		
1	Not used		
2	Not used		
3	Not used		
4	Progress Indicator information element for outgoing Speech calls	Add	Don't Add
5	Progress Indicator information element for outgoing 3.1kHz-audio calls	Add	Don't Add
6	Not used		
7	Not used		

[Bit 4]

For outgoing speech calls, the Progress Indicator information element in the SETUP message can be set to “Add” or “Don't Add.” If a progress identifier which has a suitable progress description included in the SETUP message is not used, there are cases where the SETUP message will not be received, depending on the switching equipment. In cases such as this, choose “Add.” Additionally, when “Add” is selected, the progress description included in the Progress Indicator information element takes on the same value as that set under the #4C ISDN menu in ISDN BASIC Numeric Parameter No.19.

[Bit 5]

For outgoing 3.1kHz audio calls, the Progress Indicator information element in the SETUP message can be set to “Add” or “Don't Add.” If a progress identifier which has a suitable progress description included in SETUP message is not used, there are cases where the call settings will not be received, depending on the switching equipment. In cases such as this, choose “Add.” Additionally, when “Add” is selected, the progress description included in the Progress Indicator information element takes on the same value as that set under the #4C ISDN menu in ISDN BASIC Numeric Parameter No.18.

ISDN BASIC Bitswitch SW02

Bit	Function	1	0
0	Not used		
1	Send RELCOMP message when incoming call is rejected	Yes	No
2	G4/G3 automatic fallback	No	Yes
3	3.1kHz audio/Speech automatic fallback	No	Yes
4	Not used		
5	Not used		
6	Not used		
7	Not used		

[Bit 1]

When the incoming call is rejected, sending of the RELCOMP message can be set to either Yes or No. If “No” is selected, the RELCOMP message will not be sent if an incoming call is rejected because transmission is in progress, etc.; no response is sent. If “Yes” is selected, the RELCOMP message will be sent when the incoming call is rejected. However, in cases where transmission is rejected because results of the incoming address check do not agree, the RELCOMP message will not be sent even if “Yes” is selected.

[Bit 2]

For outgoing G4 calls, it is possible to choose whether to automatically fallback to G3 in cases where an error occurs in the D-channel connection procedure. If “Yes” is selected, the machine will fallback to G3 and call again after releasing the call if notification of a “cause number” corresponding to the error code set under the #4C ISDN menu in ISDN BASIC G4/G3 Fallback is received from the network after a G4 call is made.

[Bit 3]

For outgoing 3.1kHz audio calls, it is possible to choose whether to automatically fallback to speech in cases where an error occurs in the D-channel connection procedure. If “Yes” is selected, the machine will fallback to speech and call again after releasing the call if notification of a “cause number” corresponding to the error code set under the #4C ISDN menu in ISDN BASIC Speech Fallback is received from the network after a 3.1kHz-audio call is made.

ISDN BASIC Bitswitch SW03

Bit	Function	1	0
0	Outgoing TEL call bearer capability	3.1kHz audio	SpeechNot used
1	Not used		
2	Outgoing G4 call HLC	Don't Add	Add
3	Action for incoming call when no G4HLC	Call rejected destination	G4 reception
4	Outgoing G4 call LLC	Don't Add	Add
5	Outgoing G3 call LLC	Don't Add	Add
6	Fallback table for enforced fallback	Reference	Don't Reference
7	Not used		

[Bit 0]

The bearer capability for outgoing TEL calls can be set to 3.1kHz audio or speech.

[Bit 2]

For outgoing G4 calls, the HLC (High Layer Compatibility) information element in the SETUP message can be set to "Add" or "Don't Add." This setting is available when the ISDN BASIC Bitswitch SW06 under the #4C ISDN BASIC menu Bit7 is "0."

[Bit 3]

For incoming calls, the operation of the incoming signal can be set when the HLC (High Layer Compatibility) information element in the SETUP message is set to "Don't Add." If "G4 reception" is selected, an incoming call will be handled as G4 when a SETUP message which does not contain G4HLC is received. If "Call rejected" is selected, an incoming call will be handled as "Incompatible terminal attributes" when a SETUP message which does not contain G4HLC is received.

[Bit 4]

For outgoing G4 calls, the LLC (Low Layer Compatibility) information element in the SETUP message can be set to "Add" or "Don't Add." This setting is available when the ISDN BASIC Bitswitch SW06 Bit6 under the #4C ISDN BASIC menu is "0."

[Bit 5]

For outgoing G3 calls, the LLC (Low Layer Compatibility) information element in the SETUP message can be set to "Add" or "Don't Add." If the LLC (Low Layer Compatibility) information element is added to the SETUP message, the SETUP message may not be received, depending on the switching equipment. In such cases, set to "Don't add." This setting is available when the ISDN BASIC Bitswitch SW06 Bit6 under the #4C ISDN BASIC menu is "0."

[Bit 6]

In the conditions for enforced G4/G3 fallback, it is possible to select whether or not to add "Does the error code set in the fallback table coincide with the cause number received from the network? If "Reference" is selected, the machine will fallback to G3 and call again after an outgoing G4 call even if the "cause number" corresponding to the error code set under the #4C ISDN menu in ISDN BASIC G4/G3 Fallback is received from the network. This setting is available when the ISDN BASIC Bitswitch SW08 Bit4 under the #4C ISDN BASIC menu is "0."



NOTE

Enforced fallback function

This is an function for outgoing G4 calls, in which a call is forced with G3 if there is an error in B-channel communications after normal D-channel connection.

ISDN BASIC Bitswitch SW06

Bit	Function	1	0
0	Sending Complete information element	Add	Don't Add
1	Not used		
2	Not used		
3	Not used		
4	Not used		
5	Not used		
6	LLC information element	Don't Add	Add
7	HLC information element	Don't Add	Add

[Bit 0]

For all outgoing calls, the Sending Complete information element in the SETUP message can be set to "Add" or "Don't Add." If the Sending Complete information element is not added to the SETUP message, the SETUP message may not be received, depending on the switching equipment. In such cases, set to "Add."

[Bit 6]

For all outgoing calls, the LL (Low Layer Compatibility) information element in the SETUP message can be set to "Add" or "Don't Add."

If "Don't Add" is set, ISDN BASIC Bitswitch SW03 Bit4, SW03 Bit5, and SW13 Bit0 settings under the #4C ISDN BASIC menu are unavailable.

[Bit 7]

For all outgoing calls, the HLC (High Layer Compatibility) information element in the SETUP message can be set to "Add" or "Don't Add."

If "Don't Add" is set, ISDN BASIC Bitswitch SW03 Bit2, SW08 Bit2, and SW13 Bit1 settings under the #4C ISDN BASIC menu are unavailable

ISDN BASIC Bitswitch SW07

Bit	Function	1	0
0	Not used		
1	Not used		
2	Not used		
3	Not used		
4	D-channel communications log	Save	Don't Save
5	Not used		
6	Not used		
7	Not used		

[Bit 4]

It is possible to select whether or not to log D-channel communications. To output a D-channel dump list, set to "Save."

ISDN BASIC Bitswitch SW08

Bit	Function	1	0
0	Not used		
1	Not used		
2	Outgoing G3 call HLC	Don't Add	Add
3	Not used		
4	enforced G4/G3 fallback	Yes	No
5	Calling Party Number coding change	TON: National Number NPI: National Number- ing Plan/ISDN	TON: Unknown NPI: Unknown
6	Called Party Number coding change	TON: National Number NPI: National Number- ing Plan/ISDN	TON: Unknown NPI: Unknown
7	Connected Number coding change	TON: National Number NPI: National Number- ing Plan/ISDN	TON: Unknown NPI: Unknown

[Bit 2]

For outgoing G3 calls, the HLC (High Layer Compatibility) information element in the SETUP message can be set to "Add" or "Don't Add." If the HLC (High Layer Compatibility) information element in the SETUP message is set to "Add," the SETUP message may not be received, depending on the switching equipment. In such cases, set to "Don't Add." This setting is available when ISDN BASIC Bitswitch SW06 Bit7 under the #4C ISDN menu is set to "0."

[Bit 4]

For outgoing G4 calls, if an error occurs in B-channel communications after normal D-channel connection, it is possible to choose whether or not to enforce a fallback to G3. For example, in cases such as where an outgoing G4 call is made to a G3 machine and the network returns a CONNECT message in response to the SETUP message sent by the calling machine, set to "Yes." If "Yes" is selected, ISDN BASIC Bitswitch SW03 Bit6 settings under the #4C ISDN BASIC menu are available.

[Bit 5]

It is possible to switch between the "Type of Number" (TON) coding and "Numbering Plan Identification" (NPI) coding of the Calling Party Number information element, which is included in the SETUP message.

[Bit 6]

It is possible to switch between the "Type of Number" (TON) coding and "Numbering Plan Identification" (NPI) coding of the Called Party Number information element, which is included in the SETUP message.

[Bit 7]

It is possible to switch between the "Type of Number" (TON) coding and "Numbering Plan Identification" (NPI) coding of the Connected Number information element, which is included in the CONNECT message.

ISDN BASIC Bitswitch SW13

Bit	Function	1	0
0	Not Used		
1	Not Used		
2	Bearer Capability of ON-HOOK call	Speech	3.1kHz-audio
3	Not used		
4	Not Used		
5	Not Used		
6	Incoming address check for global number incoming calls	Don't respond	Respond
7	Not used		

[Bit 2]

It is possible to set either “Speech” or “3.1kHz-audio” for the bearer capability when making an outgoing call using the ON-HOOK button.

[Bit 6]

When checking incoming addresses, the global number incoming call (No Called Party Number in SETUP messages) can be set to “Respond” or “Don't Respond.” When not checking incoming addresses, this setting is unrelated and replies will be made to the global number incoming call.

ISDN BASIC Numeric parameter

No.	Function	Selecting range	Default setting
16	Fallback Wait Time	0-255 (×100msec.)	0 (0msec.)
18	progress description of 3.1kHz-audio call-time	0-127	3
19	progress description of speech call-time	0-127	3

[No.16]

This parameter sets the time to wait between releasing the call and trying the call again when automatic G4/G3 fallback and automatic 3.1kHz-audio/Speech are done.

[No.18]

The progress description of the Progress Indicator information element included in the SETUP message can be set for outgoing 3.1kHz-audio calls. The values defined for the progress description are only 1-5 and 8.

No. Progress Description

- 1 Calling is not end-to-end ISDN; further call progress information may be available in-band
- 2 Destination address is non ISDN
- 3 Origination address is non ISDN
- 4 Call has returned to the ISDN
- 5 Interworking has occurred and has resulted in a telecommunication service change
- 8 In-band information or an appropriate pattern is now available

This setting is available when ISDN BASIC Bitswitch SW01 bit5 under the #4C ISDN BASIC menu is "1."

[No.19]

The progress description of the Progress Indicator information element included in the SETUP message can be set for outgoing speech calls. The values defined for the progress description are only 1-5 and 8.

No. Progress Description

- 1 Calling is not end-to-end ISDN; further call progress information may be available in-band
- 2 Destination address is non ISDN
- 3 Origination address is non ISDN
- 4 Call has returned to the ISDN
- 5 Interworking has occurred and has resulted in a telecommunication service change
- 8 In-band information or an appropriate pattern is now available

This setting is available when #4C ISDN BASIC Bitswitch SW01 bit4 is "1."

ISDN BASIC Redial Code

No.	Function	Selecting range	Default setting
01-128	Redial	1001-1131	See d) SSSW default setting

ISDN BASIC G4/G3 Fallback

No.	Function	Selecting range	Default setting
01-128	G4/G3 fallback	1001-1131	See d) SSSW default setting

ISDN BASIC Speech Fallback

No.	Function	Selecting range	Default setting
01-128	Speech fallback	1001-1131	See d) SSSW default setting

[Redial]

If a D-channel protocol error occurs with an outgoing call, the 4-digit error code displayed on the LCD of the machine’s this switch or on the report can be registered so that, from the next outgoing call onwards, if the same error occurs, the machine will redial.

[G4/G3 Fallback]

If a D-channel protocol error occurs with an outgoing G4 call, the 4-digit error code displayed on the LCD of the machine’s switch or on the report can be registered so that, from the next outgoing call onwards, if the same error occurs, the machine will make an outgoing G3 call after making one public call.

[Speech Fallback]

If a D-channel protocol error occurs with an outgoing G3 call with Bearer Capability “3.1kHz audio,” the 4-digit error code displayed on the LCD of the machine’s switch or on the report can be registered so that, from the next outgoing call onwards, if the same error occurs, the machine will make an outgoing G3 call with Bearer Capability “speech” after making one public call.

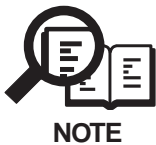

The error codes registered in #4C ISDN BASIC “Redial Code,” “G4/G3 Fallback,” and “Speech Fallback” can contain a maximum of 128 characters each.

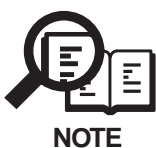

Please do not clear or otherwise change the value registered in #4C ISDN BASIC “Redial Code,” “G4/G3 Fallback,” and “Speech Fallback.” It is feared that trouble with communication will occur.

Example) G4/G3 Fallback function and operation procedure

- In the case where the FAX-L1000 makes an outgoing G4 call to a G3 machine
 - a) After the FAX-L1000 sends the SETUP message which includes the Bearer Capability information element “unrestricted digital.” notification of a DISC message containing Cause number “88” is made from the network, and a D-channel connection error occurs. Cause number “88” means “Incompatible Destination.” and the FAX-L1000 displays the service error code “##1088.” The “cause number” is set to the clearing message first notified by the network (DISC message, REL message, or RELCOMP message).

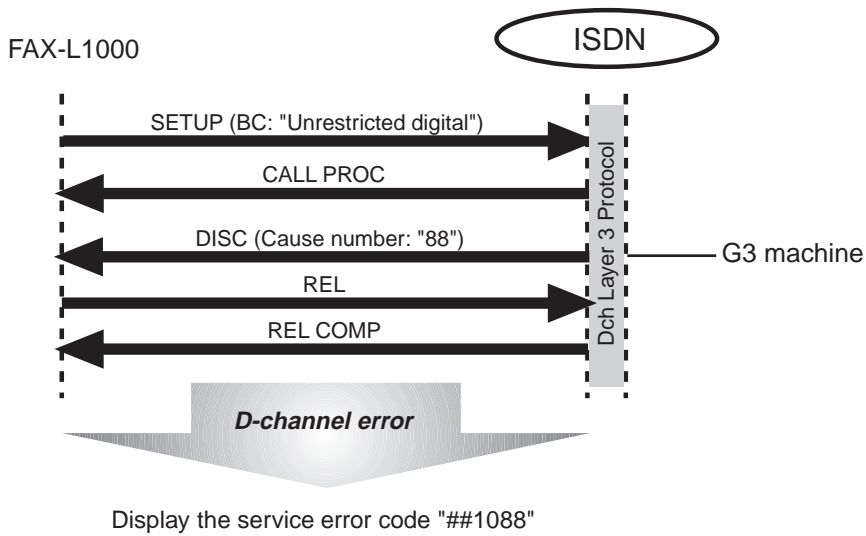

Figure 5-56 G4 → G3 Fallback Procedure (1)

b)Next, the 4 digits “1088” of the service error code “##1088” are registered in service data #4C ISDN BASIC G4/G3 Fallback, and another outgoing call is made to the G4. In this situation, with the first outgoing call, a) D-channel cannot be connected in the same way, but after receiving the RELCOMP message from the network, the Bearer Capability information element included in the SETUP message is changed from “unrestricted digital” to “3.1kHz audio” and the SETUP message is sent again.Example)

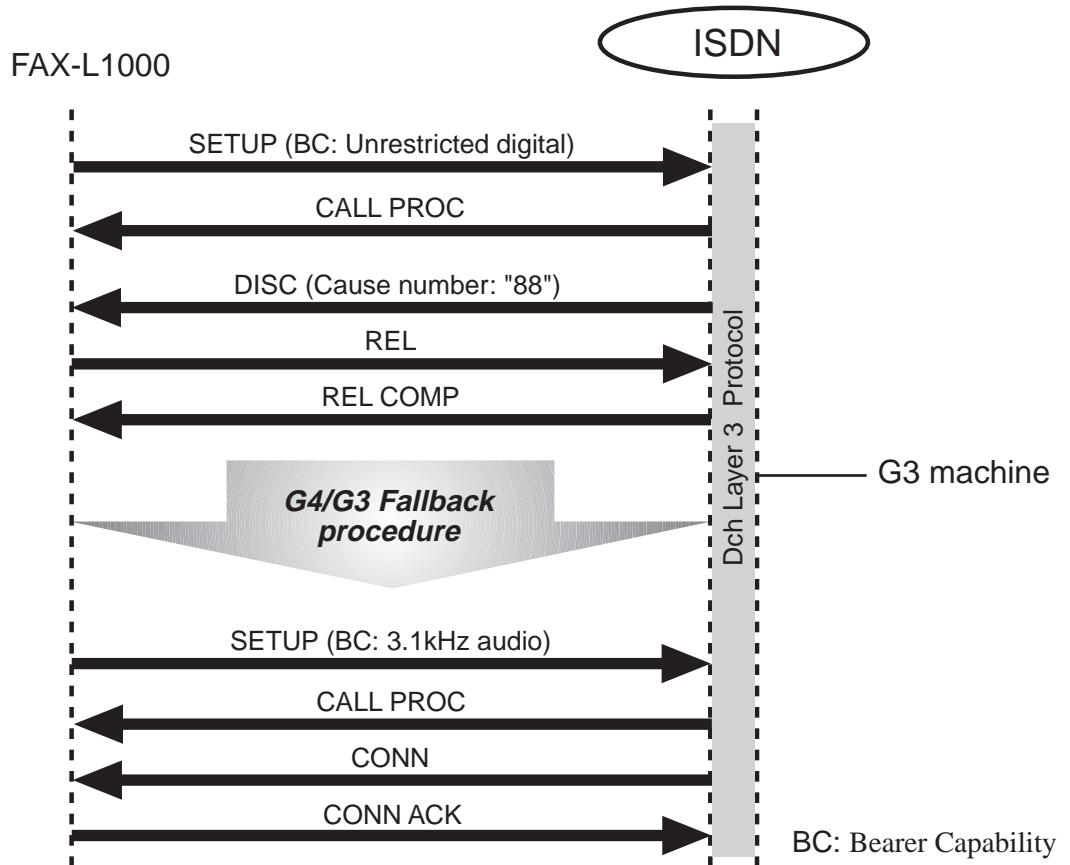

Figure 5-57 G4 → G3 Fallback Procedure (2)

ISDN G4 Bitswitch SW01

Bit	Function	1	0
0	Not used		
1	Not used		
2	Not used		
3	Multi-document transmission	Yes	No
4	Not used		
5	Not used		
6	G4 B-channel communication Log Mode	All Communications	Erroneous Communications only
7	G4 B-channel communication log	Don't Save	Save

[Bit 3]

For G4 transmission, it is possible to set whether or not to use Multi-document transmission.

[Bit 6]

In the G4 B-channel communications log, it is possible to set whether to keep logs of “All communications” or “Erroneous communications only.” This setting is available when ISDN G4 Bitswitch SW01 Bit7 under the #4C ISDN BASIC menu is “0.”

[Bit 7]

It is possible to set whether or not to keep logs of G4 B-channel communications. To print out a B-channel dump list, set to “Save.”

ISDN G3 Bitswitch SW01

Bit	Function	1	0
0	Enforced G3 calling	Yes	No
1	Not used		
2	Not used		
3	Not used		
4	Not used		
5	Not used		
6	Not used		
7	Not used		

[Bit0]

For all outgoing calls, it is possible to set whether or not to enforce G3 calling. For example, when enforced G3 calling is set to “Yes,” the call will be made with G3 even if 1-touch dial or speed dial designated as communications mode G4 is used.

ISDN G3 Numeric parameter

No.	Function	Selecting range	Default setting
01	Output time of DTMF signal output	10-9999	90 (90msec.)
02	Minimum pause time of DTMF signal output	10-9999	90 (90msec.)

[No.01]

It is possible to set the time of the DTMF signal transmission.

[No.02]

It is possible to set the minimum pause time of the DTMF signal transmission.

d) SSSW default setting

TYPE	EUROPE	GERMAN	ITALY	FRANCE
#4C ISDN				
ISDN BASIC				
Bitswitch				
SW01	00100000	00100000	00100000	00100000
SW02	01100011	01100011	11100011	01100011
SW03	01100000	01100000	01100000	01100000
SW06	00000010	00000010	00000011	00000011
SW07	00001100	00001100	00001100	00001100
SW08	00011100	00011100	00011100	00011100
SW13	00001000	00001000	00001000	00001000
NUMERIC				
Param.				
16:	0	0	0	20
18:	3	3	3	3
19:	3	3	3	3
Redial Code				
01:	1017	1017	1017	1017
02:	1018	1018	1018	1018
03:	1019	1019	1019	1019
04:	1027	1027	1027	1027
05:	1031	1031	1031	1031
06:	1034	1034	1034	1034
07:	1041	1041	1041	1041
08:	1042	1042	1042	1042
09:	1044	1044	1044	1044
10:	1049	1049	1049	1049
11:	1127	1127	1127	1127
12:	1131	1131	1131	1131
13:	1016	1016	1016	1016
14:	0	0	0	0
15:	0	0	0	0
16:	0	0	0	0
17:	0	0	0	0
18:	0	0	0	0
19:	0	0	0	0
20:	0	0	0	0
21:	0	0	0	0
22:	0	0	0	0
23:	0	0	0	0
24:	0	6	0	0

d) SSSW default setting (Continue)

TYPE	EUROPE	GERMAN	ITALY	FRANCE
25:	0	0	0	0
26:	0	0	0	0
27:	0	0	0	0
28:	0	0	0	0
29:	0	0	0	0
30:	0	0	0	0
31:	0	0	0	0
32:	0	0	0	0
33:	0	0	0	0
34:	0	0	0	0
35:	0	0	0	0
36:	0	0	0	0
37:	0	0	0	0
38:	0	0	0	0
39:	0	0	0	0
40:	0	0	0	0
41:	0	0	0	0
42:	0	0	0	0
43:	0	0	0	0
44:	0	0	0	0
45:	0	0	0	0
46:	0	0	0	0
47:	0	0	0	0
48:	0	0	0	0
49:	0	0	0	0
50:	0	0	0	0
51:	0	0	0	0
52:	0	0	0	0
53:	0	0	0	0
54:	0	0	0	0
55:	0	0	0	0
56:	0	0	0	0
57:	0	0	0	0
58:	0	0	0	0
59:	0	0	0	0
60:	0	0	0	0
61:	0	0	0	0
62:	0	0	0	0
63:	0	0	0	0
64:	0	0	0	0
65:	0	0	0	0
66:	0	0	0	0
67:	0	0	0	0

d) SSSW default setting (Continue)

TYPE	EUROPE	GERMAN	ITALY	FRANCE
68:	0	0	0	0
69:	0	0	0	0
70:	0	0	0	0
71:	0	0	0	0
72:	0	0	0	0
73:	0	0	0	0
74:	0	0	0	0
75:	0	0	0	0
76:	0	0	0	0
77:	0	0	0	0
78:	0	0	0	0
79:	0	0	0	0
80:	0	0	0	0
81:	0	0	0	0
82:	0	0	0	0
83:	0	0	0	0
84:	0	0	0	0
85:	0	0	0	0
86:	0	0	0	0
87:	0	0	0	0
88:	0	0	0	0
89:	0	0	0	0
90:	0	0	0	0
91:	0	0	0	0
92:	0	0	0	0
93:	0	0	0	0
94:	0	0	0	0
95:	0	0	0	0
96:	0	0	0	0
97:	0	0	0	0
98:	0	0	0	0
99:	0	0	0	0
100:	0	0	0	0
101:	0	0	0	0
102:	0	0	0	0
103:	0	0	0	0
104:	0	0	0	0
105:	0	0	0	0
106:	0	0	0	0
107:	0	0	0	0
108:	0	0	0	0
109:	0	0	0	0
110:	0	0	0	0

d) SSSW default setting (Continue)

TYPE	EUROPE	GERMAN	ITALY	FRANCE
111:	0	0	0	0
112:	0	0	0	0
113:	0	0	0	0
114:	0	0	0	0
115:	0	0	0	0
116:	0	0	0	0
117:	0	0	0	0
118:	0	0	0	0
119:	0	0	0	0
120:	0	0	0	0
121:	0	0	0	0
122:	0	0	0	0
123:	0	0	0	0
124:	0	0	0	0
125:	0	0	0	0
126:	0	0	0	0
127:	0	0	0	0
128:	0	0	0	0
G4/G3				
Fallback				
01:	1001	1001	1001	1001
02:	1002	1002	1002	1002
03:	1003	1003	1003	1003
04:	1004	1004	1004	1004
05:	1005	1005	1005	1005
06:	1006	1006	1006	1006
07:	1007	1007	1007	1007
08:	1008	1008	1008	1008
09:	1009	1009	1009	1009
10:	1010	1010	1010	1010
11:	1011	1011	1011	1011
12:	1012	1012	1012	1012
13:	1013	1013	1013	1013
14:	1014	1014	1014	1014
15:	1015	1015	1015	1015
16:	1018	1018	1018	1018
17:	1019	1019	1019	1019
18:	1020	1020	1020	1020
19:	1021	1021	1021	1021
20:	1022	1022	1022	1022
21:	1023	1023	1023	1023
22:	1024	1024	1024	1024

d) SSSW default setting (Continue)

TYPE	EUROPE	GERMAN	ITALY	FRANCE
23:	1025	1025	1025	1025
24:	1026	1026	1026	1026
25:	1027	1027	1027	1027
26:	1028	1028	1028	1028
27:	1029	1029	1029	1029
28:	1030	1030	1030	1030
29:	1031	1031	1031	1031
30:	1032	1032	1032	1032
31:	1033	1033	1033	1033
32:	1035	1035	1035	1035
33:	1036	1036	1036	1036
34:	1037	1037	1037	1037
35:	1038	1038	1038	1038
36:	1039	1039	1039	1039
37:	1040	1040	1040	1040
38:	1041	1041	1041	1041
39:	1043	1043	1043	1043
40:	1044	1044	1044	1044
41:	1045	1045	1045	1045
42:	1046	1046	1046	1046
43:	1047	1047	1047	1047
44:	1048	1048	1048	1048
45:	1049	1049	1049	1049
46:	1050	1050	1050	1050
47:	1051	1051	1051	1051
48:	1052	1052	1052	1052
49:	1053	1053	1053	1053
50:	1054	1054	1054	1054
51:	1055	1055	1055	1055
52:	1056	1056	1056	1056
53:	1057	1057	1057	1057
54:	1058	1058	1058	1058
55:	1059	1059	1059	1059
56:	1060	1060	1060	1060
57:	1061	1061	1061	1061
58:	1062	1062	1062	1062
59:	1063	1063	1063	1063
60:	1064	1064	1064	1064
61:	1065	1065	1065	1065
62:	1066	1066	1066	1066
63:	1067	1067	1067	1067
64:	1068	1068	1068	1068
65:	1069	1069	1069	1069

d) SSSW default setting (Continue)

TYPE	EUROPE	GERMAN	ITALY	FRANCE
66:	1070	1070	1070	1070
67:	1071	1071	1071	1071
68:	1072	1072	1072	1072
69:	1073	1073	1073	1073
70:	1074	1074	1074	1074
71:	1075	1075	1075	1075
72:	1076	1076	1076	1076
73:	1077	1077	1077	1077
74:	1078	1078	1078	1078
75:	1079	1079	1079	1079
76:	1080	1080	1080	1080
77:	1081	1081	1081	1081
78:	1082	1082	1082	1082
79:	1083	1083	1083	1083
80:	1084	1084	1084	1084
81:	1085	1085	1085	1085
82:	1086	1086	1086	1086
83:	1087	1087	1087	1087
84:	1088	1088	1088	1088
85:	1089	1089	1089	1089
86:	1090	1090	1090	1090
87:	1091	1091	1091	1091
88:	1092	1092	1092	1092
89:	1093	1093	1093	1093
90:	1094	1094	1094	1094
91:	1095	1095	1095	1095
92:	1096	1096	1096	1096
93:	1097	1097	1097	1097
94:	1098	1098	1098	1098
95:	1099	1099	1099	1099
96:	1100	1100	1100	1100
97:	1101	1101	1101	1101
98:	1102	1102	1102	1102
99:	1103	1103	1103	1103
100:	1104	1104	1104	1104
101:	1105	1105	1105	1105
102:	1106	1106	1106	1106
103:	1107	1107	1107	1107
104:	1108	1108	1108	1108
105:	1109	1109	1109	1109
106:	1110	1110	1110	1110
107:	1111	1111	1111	1111
108:	1112	1112	1112	1112

d) SSSW default setting (Continue)

TYPE	EUROPE	GERMAN	ITALY	FRANCE
109:	1113	1113	1113	1113
110:	1114	1114	1114	1114
111:	1115	1115	1115	1115
112:	1116	1116	1116	1116
113:	1117	1117	1117	1117
114:	1118	1118	1118	1118
115:	1119	1119	1119	1119
116:	1120	1120	1120	1120
117:	1121	1121	1121	1121
118:	1122	1122	1122	1122
119:	1123	1123	1123	1123
120:	1124	1124	1124	1124
121:	1125	1125	1125	1125
122:	1126	1126	1126	1126
123:	1127	1127	1127	1127
124:	1131	1131	1131	1131
125:	0	0	0	1042
126:	0	0	0	0
127:	0	0	0	0
128:	0	0	0	0
Speech Fallback				
01:	1001	1001	1001	1001
02:	1002	1002	1002	1002
03:	1003	1003	1003	1003
04:	1004	1004	1004	1004
05:	1005	1005	1005	1005
06:	1006	1006	1006	1006
07:	1007	1007	1007	1007
08:	1008	1008	1008	1008
09:	1009	1009	1009	1009
10:	1010	1010	1010	1010
11:	1011	1011	1011	1011
12:	1012	1012	1012	1012
13:	1013	1013	1013	1013
14:	1014	1014	1014	1014
15:	1015	1015	1015	1015
16:	1018	1018	1018	1018
17:	1019	1019	1019	1019
18:	1020	1020	1020	1020
19:	1021	1021	1021	1021
20:	1022	1022	1022	1022

d) SSSW default setting (Continue)

TYPE	EUROPE	GERMAN	ITALY	FRANCE
21:	1023	1023	1023	1023
22:	1024	1024	1024	1024
23:	1025	1025	1025	1025
24:	1026	1026	1026	1026
25:	1027	1027	1027	1027
26:	1028	1028	1028	1028
27:	1029	1029	1029	1029
28:	1030	1030	1030	1030
29:	1031	1031	1031	1031
30:	1032	1032	1032	1032
31:	1033	1033	1033	1033
32:	1035	1035	1035	1035
33:	1036	1036	1036	1036
34:	1037	1037	1037	1037
35:	1038	1038	1038	1038
36:	1039	1039	1039	1039
37:	1040	1040	1040	1040
38:	1041	1041	1041	1041
39:	1043	1043	1043	1043
40:	1044	1044	1044	1044
41:	1045	1045	1045	1045
42:	1046	1046	1046	1046
43:	1047	1047	1047	1047
44:	1048	1048	1048	1048
45:	1049	1049	1049	1049
46:	1050	1050	1050	1050
47:	1051	1051	1051	1051
48:	1052	1052	1052	1052
49:	1053	1053	1053	1053
50:	1054	1054	1054	1054
51:	1055	1055	1055	1055
52:	1056	1056	1056	1056
53:	1057	1057	1057	1057
54:	1058	1058	1058	1058
55:	1059	1059	1059	1059
56:	1060	1060	1060	1060
57:	1061	1061	1061	1061
58:	1062	1062	1062	1062
59:	1063	1063	1063	1063
60:	1064	1064	1064	1064
61:	1065	1065	1065	1065
62:	1066	1066	1066	1066
63:	1067	1067	1067	1067

d) SSSW default setting (Continue)

TYPE	EUROPE	GERMAN	ITALY	FRANCE
64:	1068	1068	1068	1068
65:	1069	1069	1069	1069
66:	1070	1070	1070	1070
67:	1071	1071	1071	1071
68:	1072	1072	1072	1072
69:	1073	1073	1073	1073
70:	1074	1074	1074	1074
71:	1075	1075	1075	1075
72:	1076	1076	1076	1076
73:	1077	1077	1077	1077
74:	1078	1078	1078	1078
75:	1079	1079	1079	1079
76:	1080	1080	1080	1080
77:	1081	1081	1081	1081
78:	1082	1082	1082	1082
79:	1083	1083	1083	1083
80:	1084	1084	1084	1084
81:	1085	1085	1085	1085
82:	1086	1086	1086	1086
83:	1087	1087	1087	1087
84:	1088	1088	1088	1088
85:	1089	1089	1089	1089
86:	1090	1090	1090	1090
87:	1091	1091	1091	1091
88:	1092	1092	1092	1092
89:	1093	1093	1093	1093
90:	1094	1094	1094	1094
91:	1095	1095	1095	1095
92:	1096	1096	1096	1096
93:	1097	1097	1097	1097
94:	1098	1098	1098	1098
95:	1099	1099	1099	1099
96:	1100	1100	1100	1100
97:	1101	1101	1101	1101
98:	1102	1102	1102	1102
99:	1103	1103	1103	1103
100:	1104	1104	1104	1104
101:	1105	1105	1105	1105
102:	1106	1106	1106	1106
103:	1107	1107	1107	1107
104:	1108	1108	1108	1108
105:	1109	1109	1109	1109
106:	1110	1110	1110	1110

d) SSSW default setting (Continue)

TYPE	EUROPE	GERMAN	ITALY	FRANCE
107:	1111	1111	1111	1111
108:	1112	1112	1112	1112
109:	1113	1113	1113	1113
110:	1114	1114	1114	1114
111:	1115	1115	1115	1115
112:	1116	1116	1116	1116
113:	1117	1117	1117	1117
114:	1118	1118	1118	1118
115:	1119	1119	1119	1119
116:	1120	1120	1120	1120
117:	1121	1121	1121	1121
118:	1122	1122	1122	1122
119:	1123	1123	1123	1123
120:	1124	1124	1124	1124
121:	1125	1125	1125	1125
122:	1126	1126	1126	1126
123:	1127	1127	1127	1127
124:	1131	1131	1131	1131
125:	0	0	0	1042
126:	0	0	0	0
127:	0	0	0	0
128:	0	0	0	0
ISDN G4				
Bitswitch				
SW01	10000100	10000100	10000100	10000100
ISDN G3				
Bitswitch				
SW01	00000000	00000000	00000000	00000000
ISDN G3				
NUMERIC				
Param.				
01:	90	90	90	90
02:	90	90	90	90

e) Report and List
 e-1) System data list

This list shows service data settings of service soft switches and service parameters.

```

15/01 2000 14:41 FAX                                ☑001

*****
***  SYSTEM DATA LIST  ***
*****

#1  SSSW

      SW01      ----      00010000
      SW02      ----      00000000
      SW03      ----      00000000
      SW04      ----      10000000
      SW05      ----      00000000
      SW06      ----      10000000
      SW07      ----      00000000
      SW08      ----      00000000
      SW09      ----      00000000
      SW10      ----      00000000
      SW11      ----      00000000
      SW12      ----      00000010
      SW13      ----      00000000
      SW14      ----      00000000
      SW15      ----      00000000
      SW16      ----      00000011
      SW17      ----      00000000
      SW18      ----      00000000
      SW19      ----      00000000
      SW20      ----      00000000
      SW21      ----      00000000
      SW22      ----      00000000
      SW23      ----      00000000
      SW24      ----      00000000
      SW25      ----      00000000
      SW26      ----      00000000
      SW27      ----      00000000
      SW28      ----      00000000
      SW29      ----      00000000
      SW30      ----      00000000
      SW31      ----      00000000
      SW32      ----      00000000
      SW33      ----      00000000
      SW34      ----      00000000
      SW35      ----      00000000
      SW36      ----      00000000
      SW37      ----      00000000
      SW38      ----      00000000
      SW39      ----      00000000
      SW40      ----      00000000
      SW41      ----      00000000
      SW42      ----      00000000
      SW43      ----      00000000
      SW44      ----      00000000
      SW45      ----      00000000
      SW46      ----      00000000
      SW47      ----      00000000
      SW48      ----      00000000
      SW49      ----      00000000
      SW50      ----      00000000

#2  MENU

      05:      ----      OFF
      06:      ----      DIAL
      07:      ----      10
      08:      ----      3429
      09:      ----      33.6
      10:      ----      25Hz
    
```

Figure 5-58 System Data List (1/10)

15/01 2000 14:41 FAX		002
#3 NUMERIC Param.		
01:	----	0
02:	----	10
03:	----	15
04:	----	12
05:	----	4
06:	----	4
07:	----	350
08:	----	0
09:	----	6
10:	----	5500
11:	----	3500
12:	----	0
13:	----	1320
14:	----	0
15:	----	120
16:	----	4
17:	----	100
18:	----	0
19:	----	400
20:	----	100
21:	----	0
22:	----	400
23:	----	4
24:	----	10
25:	----	60
26:	----	4
27:	----	0
28:	----	0
29:	----	0
30:	----	0
#4A SPECIAL		
SW01	----	00001000
SW02	----	10000100
SW03	----	00000000
SW04	----	00000100
SW05	----	00000000
SW06	----	00000000
SW07	----	01000000
SW08	----	01000000
SW09	----	00000000
SW10	----	00000000
SW11	----	00000000
SW12	----	00000000
SW13	----	00000000
SW14	----	00000000
SW15	----	00000000
SW16	----	00110011
SW17	----	00010000
SW18	----	00000000
SW19	----	00000000
SW20	----	00000000
SW21	----	00000000
SW22	----	00000000
SW23	----	00000000
SW24	----	00000010
SW25	----	00010101
SW26	----	00000000
SW27	----	00000000
SW28	----	00000001
SW29	----	00000010
SW30	----	00000000

Figure 5-59 System Data List (2/10)

15/01 2000 14:41 FAX 003

01 :	----	5
02 :	----	30
03 :	----	30
04 :	----	4
05 :	----	150
06 :	----	100
07 :	----	6
08 :	----	0
09 :	----	0
10 :	----	10
11 :	----	1
12 :	----	7
13 :	----	9
14 :	----	60
15 :	----	6000
16 :	----	8
17 :	----	60
18 :	----	99
19 :	----	0
20 :	----	58
21 :	----	0
22 :	----	0
23 :	----	99
24 :	----	10
25 :	----	25
26 :	----	2
27 :	----	2
28 :	----	0
29 :	----	0
30 :	----	6
31 :	----	0
32 :	----	0
33 :	----	0
34 :	----	0
35 :	----	0
36 :	----	0
37 :	----	0
38 :	----	0
39 :	----	0
40 :	----	0
41 :	----	0
42 :	----	0
43 :	----	0
44 :	----	0
45 :	----	0
46 :	----	0
47 :	----	0
48 :	----	0
49 :	----	0
50 :	----	0
51 :	----	0
52 :	----	0
53 :	----	0
54 :	----	0
55 :	----	0
56 :	----	0
57 :	----	0
58 :	----	0
59 :	----	0
60 :	----	0
61 :	----	0
62 :	----	0
63 :	----	0
64 :	----	0
65 :	----	0

Figure 5-60 System Data List (3/10)

15/01 2000 14:42 FAX			004
66 :	----	0	
67 :	----	0	
68 :	----	0	
69 :	----	0	
70 :	----	0	
#4C ISDN			
ISDN BASIC			
SW01	----	00100000	
SW02	----	01100011	
SW03	----	01100000	
SW04	----	11000000	
SW05	----	01101010	
SW06	----	00000010	
SW07	----	00001100	
SW08	----	00011100	
SW09	----	10000001	
SW10	----	00001000	
SW11	----	00000000	
SW12	----	10001010	
SW13	----	00001000	
SW14	----	00000000	
SW15	----	00000000	
SW16	----	00000000	
SW17	----	00000000	
SW18	----	00000000	
SW19	----	00000000	
SW20	----	00000000	
SW21	----	00000000	
SW22	----	00000000	
SW23	----	00000000	
SW24	----	00000000	
SW25	----	00000000	
SW26	----	00000000	
SW27	----	00000000	
SW28	----	00000000	
SW29	----	00000000	
SW30	----	00000000	
01 :	----	60	
02 :	----	3	
03 :	----	0	
04 :	----	0	
05 :	----	20	
06 :	----	20	
07 :	----	35	
08 :	----	10	
09 :	----	10	
10 :	----	10	
11 :	----	0	
12 :	----	0	
13 :	----	0	
14 :	----	0	
15 :	----	120	
16 :	----	0	
17 :	----	0	
18 :	----	3	
19 :	----	3	
20 :	----	4	
21 :	----	0	
22 :	----	0	
23 :	----	0	
24 :	----	0	
25 :	----	0	

Figure 5-61 System Data List (4/10)

15/01 2000 14:42 FAX		006
G4/G3 Fallback		
001 :	----	1001, 1002, 1003, 1004, 1005,
006 :	----	1006, 1007, 1008, 1009, 1010,
011 :	----	1011, 1012, 1013, 1014, 1015,
016 :	----	1018, 1019, 1020, 1021, 1022,
021 :	----	1023, 1024, 1025, 1026, 1027,
026 :	----	1028, 1029, 1030, 1031, 1032,
031 :	----	1033, 1035, 1036, 1037, 1038,
036 :	----	1039, 1040, 1041, 1043, 1044,
041 :	----	1045, 1046, 1047, 1048, 1049,
046 :	----	1050, 1051, 1052, 1053, 1054,
051 :	----	1055, 1056, 1057, 1058, 1059,
056 :	----	1060, 1061, 1062, 1063, 1064,
061 :	----	1065, 1066, 1067, 1068, 1069,
066 :	----	1070, 1071, 1072, 1073, 1074,
071 :	----	1075, 1076, 1077, 1078, 1079,
076 :	----	1080, 1081, 1082, 1083, 1084,
081 :	----	1085, 1086, 1087, 1088, 1089,
086 :	----	1090, 1091, 1092, 1093, 1094,
091 :	----	1095, 1096, 1097, 1098, 1099,
096 :	----	1100, 1101, 1102, 1103, 1104,
101 :	----	1105, 1106, 1107, 1108, 1109,
106 :	----	1110, 1111, 1112, 1113, 1114,
111 :	----	1115, 1116, 1117, 1118, 1119,
116 :	----	1120, 1121, 1122, 1123, 1124,
121 :	----	1125, 1126, 1127, 1131, 0,
126 :	----	0, 0, 0
Speech Fallback		
001 :	----	1001, 1002, 1003, 1004, 1005,
006 :	----	1006, 1007, 1008, 1009, 1010,
011 :	----	1011, 1012, 1013, 1014, 1015,
016 :	----	1018, 1019, 1020, 1021, 1022,
021 :	----	1023, 1024, 1025, 1026, 1027,
026 :	----	1028, 1029, 1030, 1031, 1032,
031 :	----	1033, 1035, 1036, 1037, 1038,
036 :	----	1039, 1040, 1041, 1043, 1044,
041 :	----	1045, 1046, 1047, 1048, 1049,
046 :	----	1050, 1051, 1052, 1053, 1054,
051 :	----	1055, 1056, 1057, 1058, 1059,
056 :	----	1060, 1061, 1062, 1063, 1064,
061 :	----	1065, 1066, 1067, 1068, 1069,
066 :	----	1070, 1071, 1072, 1073, 1074,
071 :	----	1075, 1076, 1077, 1078, 1079,
076 :	----	1080, 1081, 1082, 1083, 1084,
081 :	----	1085, 1086, 1087, 1088, 1089,
086 :	----	1090, 1091, 1092, 1093, 1094,
091 :	----	1095, 1096, 1097, 1098, 1099,
096 :	----	1100, 1101, 1102, 1103, 1104,
101 :	----	1105, 1106, 1107, 1108, 1109,
106 :	----	1110, 1111, 1112, 1113, 1114,
111 :	----	1115, 1116, 1117, 1118, 1119,
116 :	----	1120, 1121, 1122, 1123, 1124,
121 :	----	1125, 1126, 1127, 1131, 0,
126 :	----	0, 0, 0
Othernetwork		
Network A		
SW01	----	00000001
SW02	----	00000000
Address		
Subaddress		

Figure 5-63 System Data List (6/10)

15/01 2000 14:42 FAX			007
Network B			
SW01	----	00000000	
SW02	----	00000000	
Address			
Subaddress			
Network C			
SW01	----	00000000	
SW02	----	00000000	
Address			
Subaddress			
ISDN G4			
SW01	----	10000100	
SW02	----	00000000	
SW03	----	00000000	
SW04	----	00000000	
01 :	----	4	
02 :	----	0	
03 :	----	45	
04 :	----	6	
05 :	----	45	
06 :	----	4	
07 :	----	60	
08 :	----	60	
09 :	----	4	
10 :	----	40	
11 :	----	1	
12 :	----	30	
13 :	----	4	
14 :	----	4	
15 :	----	4	
16 :	----	4	
17 :	----	1	
18 :	----	1	
19 :	----	2	
20 :	----	10	
21 :	----	2	
22 :	----	10	
23 :	----	3	
24 :	----	230	
25 :	----	3	
26 :	----	100	
27 :	----	1	
28 :	----	3	
29 :	----	1800	
30 :	----	1800	
31 :	----	1800	
32 :	----	0	
33 :	----	0	
34 :	----	0	
35 :	----	0	
36 :	----	0	
37 :	----	0	
38 :	----	0	
39 :	----	0	
40 :	----	0	

Figure 5-64 System Data List (7/10)

15/01 2000 14:43 FAX			008
41 :	----	0	
42 :	----	0	
43 :	----	0	
44 :	----	0	
45 :	----	0	
46 :	----	0	
47 :	----	0	
48 :	----	0	
49 :	----	0	
50 :	----	0	
ISDN G4 Circuit			
SW01	----	00000000	
SW02	----	00000000	
01 :	----	15	
02 :	----	0	
03 :	----	60	
04 :	----	4	
05 :	----	20	
06 :	----	7	
07 :	----	0	
08 :	----	4	
09 :	----	2	
10 :	----	7	
11 :	----	180	
12 :	----	200	
13 :	----	180	
14 :	----	180	
15 :	----	60	
16 :	----	1	
17 :	----	1	
18 :	----	1	
19 :	----	0	
20 :	----	0	
21 :	----	0	
22 :	----	0	
23 :	----	0	
24 :	----	0	
25 :	----	0	
26 :	----	0	
27 :	----	0	
28 :	----	0	
29 :	----	0	
30 :	----	0	
ISDN G4 Packet			
SW01	----	00000000	
SW02	----	00000000	
01 :	----	3	
02 :	----	0	
03 :	----	60	
04 :	----	4	
05 :	----	25	
06 :	----	7	
07 :	----	0	
08 :	----	3	
09 :	----	2	
10 :	----	2	
11 :	----	180	
12 :	----	200	
13 :	----	180	
14 :	----	180	
15 :	----	60	

Figure 5-65 System Data List (8/10)

15/01 2000 14:43 FAX			009
16 :	----		1
17 :	----		1
18 :	----		1
19 :	----		0
20 :	----		0
21 :	----		0
22 :	----		0
23 :	----		0
24 :	----		0
25 :	----		0
26 :	----		0
27 :	----		0
28 :	----		0
29 :	----		0
30 :	----		0
ISDN G3			
SW01	----		00000000
SW02	----		00000000
SW03	----		00000000
SW04	----		00000000
01 :	----		90
02 :	----		90
03 :	----		12
04 :	----		14
05 :	----		0
06 :	----		0
07 :	----		0
08 :	----		0
09 :	----		0
10 :	----		0
11 :	----		0
12 :	----		0
13 :	----		0
14 :	----		0
15 :	----		0
16 :	----		0
17 :	----		0
18 :	----		0
19 :	----		0
20 :	----		0
#5 TYPE			
TYPE	----		EUROPE
#7 PRINTER			
SW01	----		00000000
SW02	----		00000000
SW03	----		00000000
SW04	----		00000000
SW05	----		00000000
SW06	----		00000100
SW07	----		00000000
SW08	----		00000000
SW09	----		00000000
SW10	----		00000000
SW11	----		00000000
SW12	----		00000000
SW13	----		00000000
SW14	----		00000000
SW15	----		00000000

Figure 5-66 System Data List (9/10)

15/01 2000 14:43 FAX			010
SW16	-----	00000000	
SW17	-----	00000000	
SW18	-----	00000000	
SW19	-----	00000000	
SW20	-----	00000000	
01 :	-----	15	
02 :	-----	0	
03 :	-----	0	
04 :	-----	2	
05 :	-----	7	
06 :	-----	0	
07 :	-----	0	
08 :	-----	0	
09 :	-----	0	
10 :	-----	0	
11 :	-----	0	
12 :	-----	0	
13 :	-----	0	
14 :	-----	0	
15 :	-----	0	
16 :	-----	0	
17 :	-----	0	
18 :	-----	0	
19 :	-----	0	
20 :	-----	0	
21 :	-----	0	
22 :	-----	0	
23 :	-----	0	
24 :	-----	0	
25 :	-----	0	
26 :	-----	0	
27 :	-----	0	
28 :	-----	0	
29 :	-----	0	
30 :	-----	0	
#9 ROM			
VERSION		EC-01-01	
		EC-01-01	
		EC-01-01	
START DATE			
DATE	-----	15/01 '00	

Figure 5-67 System Data List (10/10)

Displays error information for the 3 most recent communication.

```

20/01 2000 18:13 FAX 1234567890          Canon          ☑003
#1 LATEST                                #0000

START TIME                20/01 15:51
OTHER PARTY                46 8 4494016
MAKER CODE                 10001000
MACHINE CODE              11100110 00000000
RCV V.8 FRAME             E0 81 85 D4 90 7E 00 00
SYMBOL RATE               3200
DATA RATE                 24.0
TX LVL REDUCTION          0
ERR ABCODE                00
ERR SECTXB                00
ERR SECRXB                00

Rx : (bit 1) 00000000 01000000 00011111 00100011 00000001 00100000 00000000 (bit56)
Tx : (bit 1) 00000100 01110011 00010101 00100011 00000001 10101001 00000001 (bit56)
      (bit57) 00000001 00000001 00000100 00000000 00000000 (bit96)

```

Rx :	PIX-240 PPS-EOM	NSS TSI DCS	PIX-240 PPS-NUL	PIX-240 PPS-EOM	
Tx :	CFR	MCF	CFR	MCF	
Rx :	NSS TSI DCS	PIX-240 PPS-NUL	PIX-240 PPS-NUL	PIX-240 PPS-EOP	DCN
Tx :	CFR	MCF	MCF	MCF	

```

#2                                #0000

START TIME                20/01 15:19
OTHER PARTY                46 8 4494016
MAKER CODE                 10001000
MACHINE CODE              11100110 00000000
RCV V.8 FRAME             E0 81 85 D4 90 7E 00 00
SYMBOL RATE               3200
DATA RATE                 24.0
TX LVL REDUCTION          0
ERR ABCODE                00
ERR SECTXB                00
ERR SECRXB                00

Rx : (bit 1) 00000000 01000010 00011111 00100010 00000000 00000000 00000000 (bit56)
Tx : (bit 1) 00000100 01110011 00010101 00100011 00000001 10101001 00000001 (bit56)
      (bit57) 00000001 00000001 00000100 00000000 00000000 (bit96)

```

Rx :	240 PPS-NUL	PIX-240 PPS-NUL	PIX-240 PPS-NUL	PIX-240 PPS-NUL	PIX-
Tx :	MCF	MCF	MCF	MCF	
Rx :	240 PPS-NUL	PIX-240 PPS-NUL	PIX-240 PPS-NUL	PIX-240 PPS-EOP	DCN
Tx :	MCF	MCF	MCF	MCF	

Figure 5-70 System Dump List (3/3)

e-4) Dch log report

This list shows the D-channel communication history. Up to the latest 32 messages can be displayed.

20/01 2000 18:11 FAX 1234567890		Canon		001
***** *** DCH LOG REPORT *** *****				
*1	*2	*3	*4	*5
20/01 14:10:03	03022505	<RX	REL_COMP	08 01 04 5A
20/01 14:11:05	03084610	TX>	SETUP *6	08 01 04 05 04 02 88 90 18 01 83 6C 0C 00 80 30 32 39 37 37 30 31 35 37 35 70 0E 80 30 30 31 34 36 38 34 34 39 34 30 31 36 7C 02 88 90 7D 02 91 AI
20/01 14:11:05	03084780	<RX	CALL_PROC	08 01 84 02 18 01 89
20/01 14:11:09	03088490	<RX	ALERT	08 01 84 01
20/01 14:11:09	03088555	<RX	CONN	08 01 84 07
20/01 14:11:09	03088560	TX>	CONN_ACK	08 01 04 0F
20/01 14:12:12	03151325	TX>	DISC	08 01 04 45 08 02 80 90
20/01 14:12:12	03151465	<RX	REL	08 01 84 4D
20/01 14:12:12	03151470	TX>	REL_COMP	08 01 04 5A *8
20/01 14:13:02	03201210	<RX	SETUP	08 01 05 05 04 03 90 90 A2 18 01 89 1E 02 80 83 6C 02 00 A1 70 07 80 37 30 31 35 37 35
20/01 14:13:02	03201350	TX>	CONN	08 01 85 07 4C 0C 00 80 30 32 39 37 37 30 31 35 37 35
20/01 14:13:02	03201520	<RX	STAT	08 01 05 7D 08 03 82 E3 4C 14 01 08
20/01 14:13:02	03201580	<RX	CONN_ACK	08 01 05 0F
20/01 14:16:27	03406860	<RX	DISC	08 01 05 45 08 02 80 90 1E 02 82 88
20/01 14:16:27	03406895	TX>	REL	08 01 85 4D
20/01 14:16:27	03407050	<RX	REL_COMP	08 01 05 5A
20/01 14:21:48	03727480	TX>	SETUP	08 01 05 05 04 02 88 90 18 01 83 6C 0C 00 80 30 32 39 37 37 30 31 35 37 35 70 0E 80 30 30 31 34 36 38 34 34 39 34 30 31 36 7C 02 88 90 7D 02 91 AI
20/01 14:21:48	03727645	<RX	CALL_PROC	08 01 85 02 18 01 89
20/01 14:21:52	03731740	<RX	ALERT	08 01 85 01
20/01 14:21:52	03731805	<RX	CONN	08 01 85 07
20/01 14:21:52	03731810	TX>	CONN_ACK	08 01 05 0F
20/01 14:25:27	03946840	TX>	DISC	08 01 05 45 08 02 80 90
20/01 14:25:27	03946980	<RX	REL	08 01 85 4D
20/01 14:25:27	03946985	TX>	REL_COMP	08 01 05 5A
20/01 14:26:06	03985395	<RX	SETUP	08 01 06 05 04 03 90 90 A2 18 01 89 1E 02 8A 81 6C 02 00 C3 70 07 80 37 30 31 35 37 35
20/01 14:26:06	03985495	TX>	CONN	08 01 86 07 4C 0C 00 80 30 32 39 37 37 30 31 35 37 35
20/01 14:26:06	03985645	<RX	STAT	08 01 06 7D 08 03 82 E3 4C 14 01 08
20/01 14:26:06	03985705	<RX	CONN_ACK	08 01 06 0F
20/01 14:35:50	04569860	<RX	DISC	08 01 06 45 08 02 87 90 1E 02 82 88
20/01 14:35:50	04569895	TX>	REL	08 01 86 4D
20/01 14:35:51	04570050	<RX	REL_COMP	08 01 06 5A
20/01 14:49:38	05398225	TX>	SETUP	08 01 06 05 04 02 88 90 18 01 83 6C 0C 00 80 30 32 39 37 37 30 31 35 37 35 70 0E 80 30 30 31 34 36 38 34 34 39 34 30 31 36 7C 02 88 90 7D 02 91 AI
20/01 14:49:38	05398420	<RX	CALL_PROC	08 01 86 02 18 01 89
20/01 14:49:42	05402130	<RX	ALERT	08 01 86 01
20/01 14:49:42	05402255	<RX	CONN	08 01 86 07
20/01 14:49:42	05402260	TX>	CONN_ACK	08 01 06 0F
20/01 14:50:09	05428955	TX>	DISC	08 01 06 45 08 02 80 90
20/01 14:50:09	05429075	<RX	REL	08 01 86 4D
20/01 14:50:09	05429075	TX>	REL_COMP	08 01 06 5A
20/01 14:51:02	05481555	<RX	SETUP	08 01 07 05 04 03 90 90 A2 18 01 89 1E 02 80 83 6C 02 00 A1 70 07 80 37 30 31 35 37 35
20/01 14:51:02	05481655	TX>	CONN	08 01 87 07 4C 0C 00 80 30 32 39 37 37 30 31 35 37 35
20/01 14:51:02	05481805	<RX	STAT	08 01 07 7D 08 03 82 E3 4C 14 01 08
20/01 14:51:02	05481865	<RX	CONN_ACK	08 01 07 0F
20/01 14:52:26	05565965	<RX	DISC	08 01 07 45 08 02 80 90 1E 02 82 88
20/01 14:52:26	05566000	TX>	REL	08 01 87 4D
20/01 14:52:26	05566155	<RX	REL_COMP	08 01 07 5A

Figure 5-71 Dch Log Report

•How to View the Dch dump list

a) Title Column

- *1: Date and Time.
- *2: Elapsed time since the power was turned ON (msec.). Increases every 5 msec..
- *3: Message direction.
 - TX>: The message the machine sent
 - <RX: The message the network sent
- *4: Message Name. “(L2)” shows that the message is a Layer 2 message.
- *5: Message’s parameter. Displayed as hexadecimal numbers, 2 numbers of one octet each.

b) D-channel Layer 2 Messages

The D-channel Layer 2 message (SABME, UA, etc.) is not shown in the Dch dump list. It shows messages processed inside the machine.

- EST REQ: Machine sends SABME message
- EST CNF: The UA message is received from the network pertaining to the SABME message which was sent by the machine
- EST IND: The UA message is sent from the machine pertaining to the SABME message received by the network
- REL REQ: Machine sends a DISC message
- REL CNF: The UA message is received from the network pertaining to the DISC message sent by the machine
- REL IND: The UA message is sent from the machine pertaining to the DISC message received from the network. Additionally, depending on the cause for the removal of ISDN line, even when Layer 2 has been disconnected, the main message is still shown.

c) D-channel Layer 3 Message and Information Element

Normally, 4-octets of header information are attached to a D-channel Layer 3 message. (*6) The length of the header information varies according to the value of the 2nd octet. For example, when the value of the 2nd octet is “00,” the header information length is 3 octets, and when then value of the 2nd octet is “01,” the header information length is 4 octets. The information elements will be displayed following the header information. (*7)

There are 2 types of information element: single octet information element and variable length information element.

c-1) Single Octet Information Elements

The Sending Complete information element which is included in the SETUP message can be used by this machine. The service data #4B ISDN BASIC Bitswitch SW06 bit0 is set to “1,” and when there is an outgoing call, on the Dch dump list right after the header information in the SETUP message sent by this machine, the main information is shown, and “A1” is set.

c-2) Variable Length Information Elements

The main information element is composed of an information element identifier (1 octet), an length of contents of information element (1 octet), and an contents of information element (the length of octet which is shown by the “length of contents of information element”).

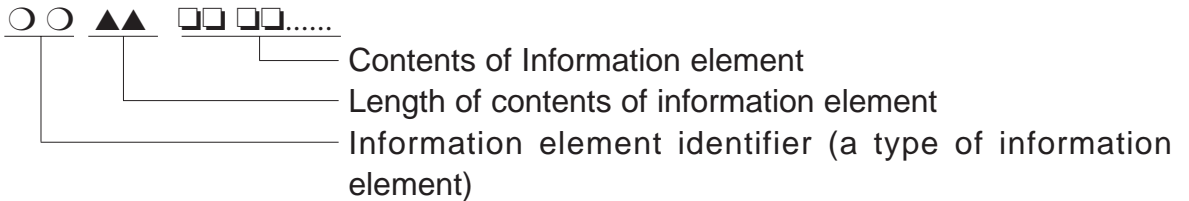

For example, if an length of contents of information element value is “02,” the contents of information element is 2 octets.

The way in which the SETUP message and the main information elements in the clearing message are displayed on the Dch dump list is shown below.

c-3) Main information elements in the SETUP message

•Bearer Capability (*8)

Number 1 octet : “04”

Number 3 octet : Information transfer capacity

“88”: Unrestricted digital

“90”: 3.1kHz audio

“80”: Speech

•Channel Identification (*9)

Number 1 octet : “18”

Number 3 octet : Information channel selection

“80”: No channel

“81”: B1 channel

“82”: B2 channel

“83”: Any channel

•Calling Party Number (*10)

Number 1 octet : “6C”

From number 4 or number 5 octet on*: Number digit (IA5 character)

*: When the most significant bit of number 3 octet is “0,” number digits will appear in number 5 octet onwards. When the most significant bit of number 3 octet is “1,” number digits will appear in number 4 octet onwards.

•Low Layer Compatibility (*12)

Number 1 octet : “7C”

Number 3 octet : Information transfer capability

“88”: Unrestricted digital

“90”: 3.1kHz audio

“80”: Speech

•High Layer Compatibility (*13)

Number 1 octet : “7D”

Number 4 octet : High layer characteristics identification

“A1”: G4

“84”: G2/G3

“81”: TEL

•Progress Indicator (*14)

Number 1 octet : “1E”

Number 4 octet : Progress description

“81”: Call is not end-to-end ISDN; further call progress information may be available in-band

“82”: Destination address is non ISDN

“83”: Origination address is non ISDN

“84”: Call has returned to the ISDN

“85”: Interworking has occurred and has resulted in a telecommunication service change

“88”: In-band information or an appropriate pattern is now available

c-4) Main information elements in the clearing message (DISC, REL, RELCOMP)

•Cause

Number 1 octet : “08”

Number 4 octet and on: Cause number



NOTE

Cause number

The “cause number” is the number which results when “80” is subtracted from the number displayed on the Dch dump list and the result is converted to decimal form. For example, in the case where the number displayed on the Dch dump list is “90,” if “80” is subtracted from “90,” “10” is the result. When this is converted to decimal form, “16” -the cause number - results.

Information element description

The actual information element description is regulated by the bit unit, but in the information descriptions in this manual assume a general situation and are shown by octet bit. If values outside of those shown in this manual appear on the Dch dump list, please check the ITU-T recommendations and the ETSI standards.

e-4) Bch Log report

This report shows B-channel communication history. Up to the latest 3 communications can be displayed

*5	*6	*7	*8
20/01 2000 18:10 FAX 1234567890	Canon		001
***** *** BCH LOG REPORT *** *****			
*1 Commu. No. : 0012			
*2 Error Code : ##1336			
*3 Start Time : 20/01 15:49:54			
*4 End Time : 20/01 15:50:57			
00803505	TX>	SABM	01 3F
00804145	<RX	UA	01 73
00804150	TX>	SQ	10 00 FB 00 00
00804485	<RX	SF	10 00 FF
00804490	TX>	CR	10 01 0B 00 06 42 0B 0B 43 07 07 02
00804830	<RX	CC	10 01 0F 00 06 42 0B 0B 43 07 07
00804835	TX>	TCR	09 E0 00 00 30 30 00 C0 01 0B
00805190	<RX	TCA	09 D0 30 30 31 31 00 C0 01 0B
00805195	TX>	CSS	0D 48 01 2A 0A 18 30 32 39 37 20 37 30 20 31 35 37 35 3D 00 00 00 00 00 00 00 00 00 00 00 0B 0E 30 30 2D 30 31 2D 32 30 2D 31 35 3A 34 39 02 03 0E 01 01 08 01 01 C1 08 A4 06 80 01 02 81 01 00 E8 08 00 01 11 00 01 01 00 01
00805630	<RX	RSSP	0E 48 01 2A 09 18 34 36 20 38 20 34 34 39 34 30 31 36 3D 00 00 00 00 00 00 00 00 00 00 00 0B 0E 30 30 2D 30 31 2D 32 30 2D 31 35 3A 34 39 02 03 0E 01 01 08 01 01 C1 08 A4 06 80 01 02 81 01 00 E8 08 00 01 11 00 01 01 00 01
00805645	TX>	CDCL	01 00 3D 71 C1 52 A4 50 80 01 02 81 01 00 A2 41 A2 32 30 08 80 02 26 C0 81 02 36 CE 30 08 80 02 2E 23 81 02 41 25 30 08 80 02 2F 6D 81 02 43 2C 30 08 80 02 36 CE 81 02 4D 80 30 08 80 02 2F 6C 81 02 43 2C A4 03 8B 01 04 BD 06 86 04 00 14 55 00 E4 05 E1 03 C0 01 01 E8 1B 00 01 11 00 01 01 00 01 F9 11 80 45 59 50 2D 33 32 20 20 20 20 20 20 20 20 20 20
00806055	<RX	RDCLP	02 00 3E 41 C1 22 A4 20 80 01 02 81 01 00 A2 11 A2 0A 30 08 80 02 26 C0 81 02 36 CE A4 03 8B 01 04 E4 05 E1 03 C0 01 01 E8 1B 00 01 11 00 01 01 00 01 F9 11 80 43 41 4E 4F 4E 20 53 57 45 44 45 4E 20 20 20 20
00806090	TX>	CDS	01 00 2D 29 29 03 30 30 32 C1 22 A4 20 80 01 02 81 01 00 A2 11 A2 0A 30 08 80 02 26 C0 81 02 36 CE A4 03 8B 01 04 E4 05 E1 03 C0 01 01
00806120	TX>	P-START	01 00 01 00 A2 03 02 01 00 A2 14 02 01 02 31 0F A4 08 80 02 26 C0 81 02 36 CE E9 03 C0 01 01 A3 80 24 80
00812080	TX>	P-END	01 00 01 00 00 00 00 00
00812110	TX>	CDPB	01 00 31 05 2A 03 30 30 31
00813900	<RX	RDPPB	02 00 32 08 2A 03 30 30 31 2E 01 00
00813910	TX>	P-START	01 00 01 00 A2 0F 02 01 02 31 0A A4 08 80 02 26 C0 81 02 36 CE A3 80 24 80
00822160	TX>	P-END	01 00 01 00 00 00 00 00
00822190	TX>	CDPB	01 00 31 05 2A 03 30 30 32
00824890	<RX	RDPPB	02 00 32 08 2A 03 30 30 32 2E 01 00
00824900	TX>	P-START	01 00 01 00 A2 16 02 01 02 31 11 A4 08 80 02 26 C0 81 02 36 CE A6 05 A1 03 82 01 04 A3 80 31 06 A2 04 80 02 0D 80 24 80
00843910	TX>	P-END	01 00 01 00 00 00 00 00
00843940	TX>	CDPB	01 00 31 05 2A 03 30 30 33
00845430	<RX	RDPPB	02 00 32 08 2A 03 30 30 33 2E 01 00
00845435	TX>	P-START	01 00 01 00 A2 16 02 01 02 31 11 A4 08 80 02 26 C0 81 02 36 CE A6 05 A1 03 82 01 04 A3 80 31 06 A2 04 80 02 0D 80 24 80
00862015	<RX	CSA	19 03 11 01 01
00862015	TX>	RSAP	1A 00

Figure 5-72 Bch Log Report

•How to View the Bch dump list

a) Title Column

- *1: Communication Number.
- *2: Error Code. “None” will be shown for normal communications.
- *3: When B-channel communication has commenced.
- *4: When B-channel communication has completed.
- *5: Elapsed time since the power was turned ON (msec.). Increases every 5 msec.
- *6: Message direction.
 - TX>: The message the machine sent
 - <RX: The message the network sent
- *7: Message name.
- *8: Message’s parameter. Displayed as hexadecimal numbers, 2 numbers of one octet each.

3.6.4 G4 board components

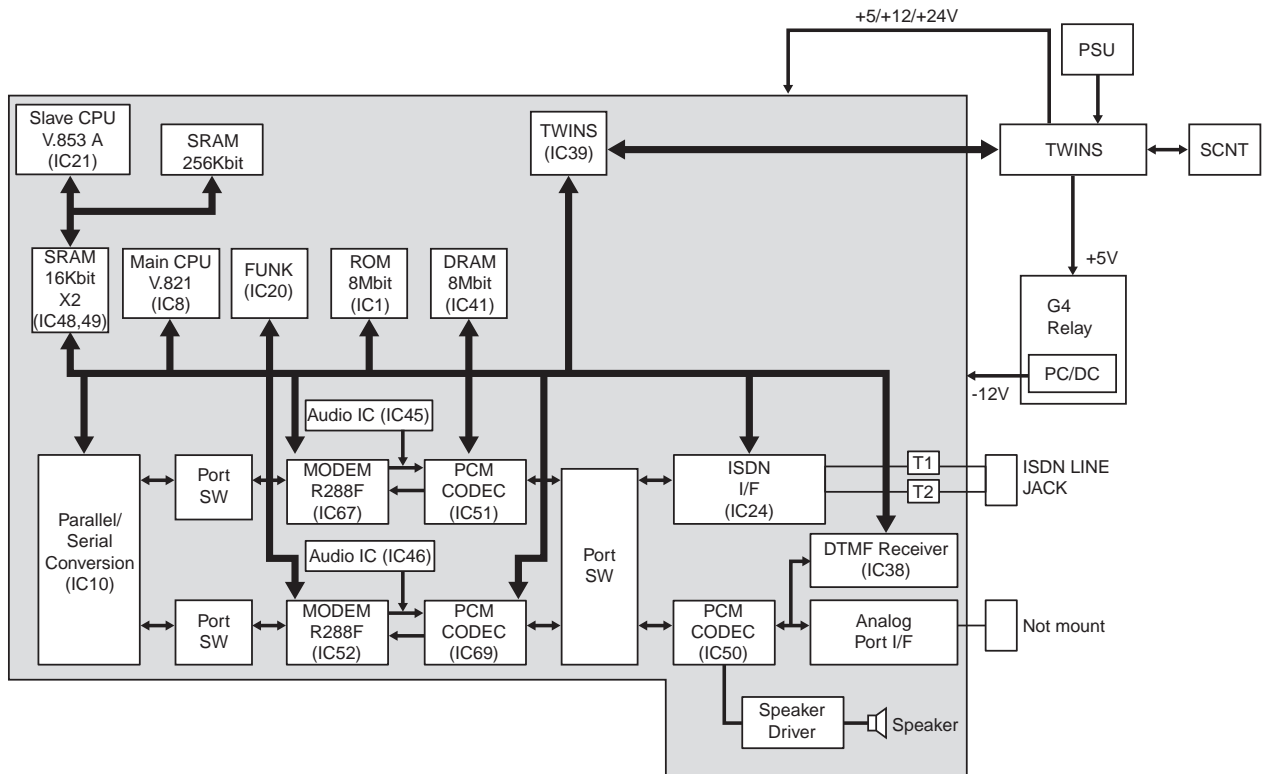

Fig. 5-73 Component block diagram

a) DTMF signal detection circuit

This circuit uses a dedicated IC (IC38 DTMF receiver) to detect a DTMF signal.

b) ISDN interfade IC (IC24)

This YAMAHA-made IC YM7405C has Layer 1 functions, Layer 2 functions(LAPD), and Layer 3 interface functions for connection to an ISDN circuit.

c) PCM CODEC IC (IC51, IC69)

The PCM CODEC IC, OKI-made MSK7578VMS-K, converts analog audio signals output from a G3 modem to PCM digital signals to implement G3 transmission through ISDN lines. This IC converts PCM digital signals to analog audio signals.

d) Modem IC (IC52, IC67)

The modem IC, CONEXANT R288F, G3-modulates transmit data received from a CPU according to ITU-T V.17, V.21, V.27ter, V.29, and V.34 in transmit mode. This IC G3-demodulates the signal received through the line according to ITU-T V.17, V.21, V.27ter, V.29, and V.34 in receive mode. The IC detects a DTMF signal through ISDN lines.

e) PCM CODEC IC (IC50)

This IC converts receive signals (digital signals through ISDN lines) to analog signals. It converts transmit signals (analog audio signals) to digital signals.

f) Slave CPU (IC21)

The slave CPU, NEC-made uPD70F3025AGC-33 (V.853), converts encode data (MH, MR, MMR, JBIG, etc.) from the transmit circuit to encode data (MR) for the SCNT board in receive mode. The CPU converts encode data (MR) from the SCNT board to encode data (MH, MR, MMR, JBIG, etc.) suitable for the remote machine.

g) Main CPU (IC8)

The main CPU, NEC-made uPD70741GC-25-TEA (V.821), controls operations in the same way as the CPU (IC17) on the SNCT board.

h) System controller (IC20)

The system controller, MITSUBISHI-made M66364FP, is a standard cell that controls peripheral devices for the MPU. It contains peripheral IC chip select, DRAM control, and DMA controller.

i) ROM (IC1)

The 1M-byte ROM contains a transmission control (V.821) program.

j) DRAM (IC41)

The 1M-byte DRAM is used to store image data in transmit and receive modes and as a work area for the CPU.

k) TWINS IC (IC39)

This NEC-made gate-array UPD65802GJ-117-3EN controls the IEEE1284's dual-party transmission port.

l) Parallel/serial conversion IC (IC10)

The parallel/serial conversion IC, HITACHI-made HD64570F16, converts serial signals from a modem to parallel signals in G3 transmission. It converts serial signals from an ISDN line to parallel signals in G4 transmission.

3.6.5 Flow of Image Signals

a) Transmission

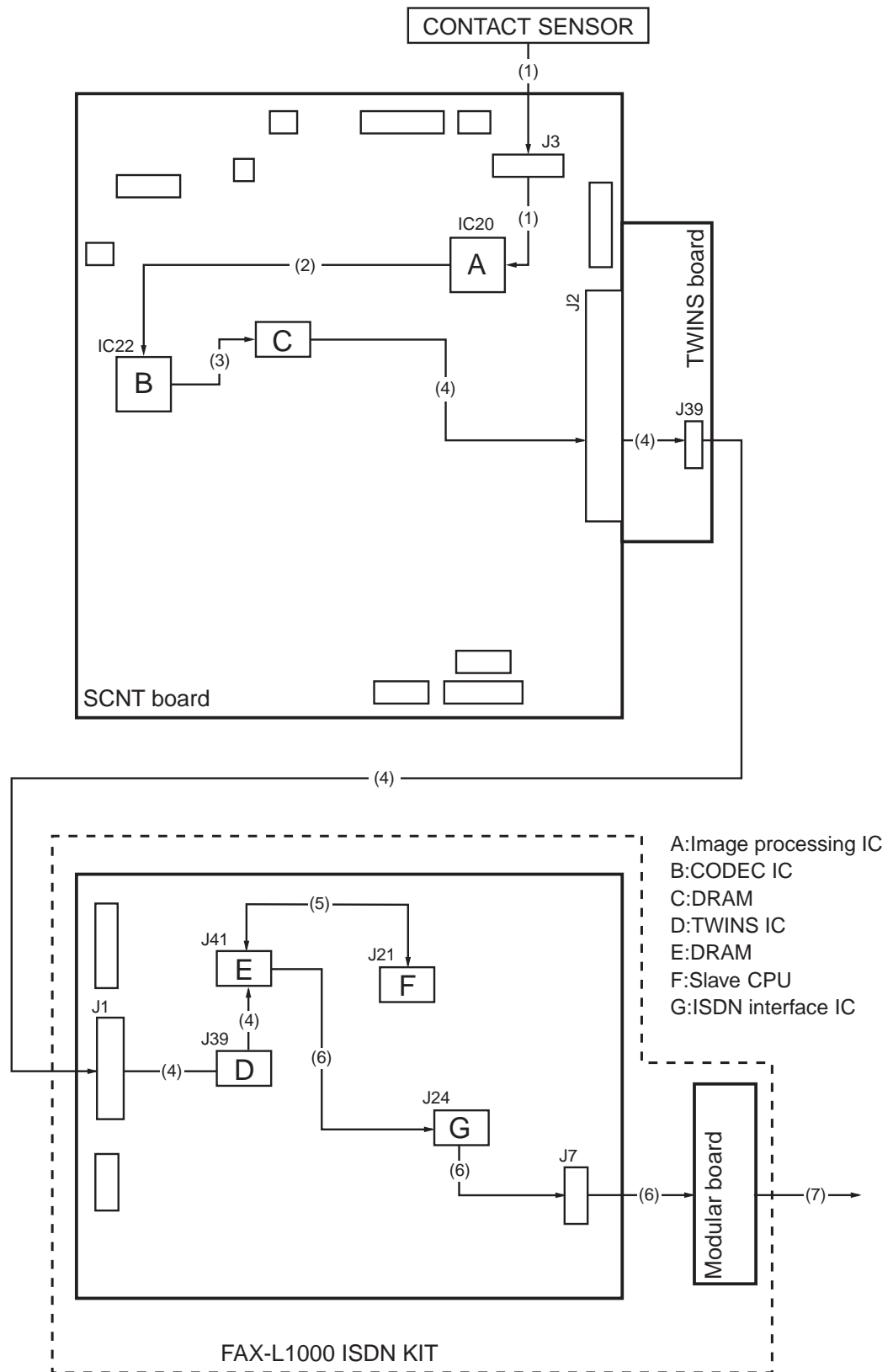

Figure 5-74 Transmission Image Signal Flow

- (1) The image is scanned by the contact sensor, and the analog image data is sent to the SCNT board.
- (2) The image processing IC (IC20) converts the analog image data from the contact sensor into digital data.
- (3) The digitized data is encoded by the CODEC IC in an MR with no compression function, and transferred to DRAM (IC3) by high-speed DMA transfer.
- (4) The MR encode data stored in the DRAM is transferred to the DRAM on the FAX-L1000 ISDN Kit through the TWINS board.
- (5) The MR encode data sent to the DRAM is converted to raw data by the slave CPU, and then encoded into a format (such as MMR and JBIG) suitable for the remote machine.
- (6) The data encoded into MMR, JBIG, etc. is added with a header and sent to the ISDN interface IC through a modular board.
- (7) The encoded data is transferred to the ISDN line through the modular jack of the FAX-L1000 ISDN Kit.

b) Reception

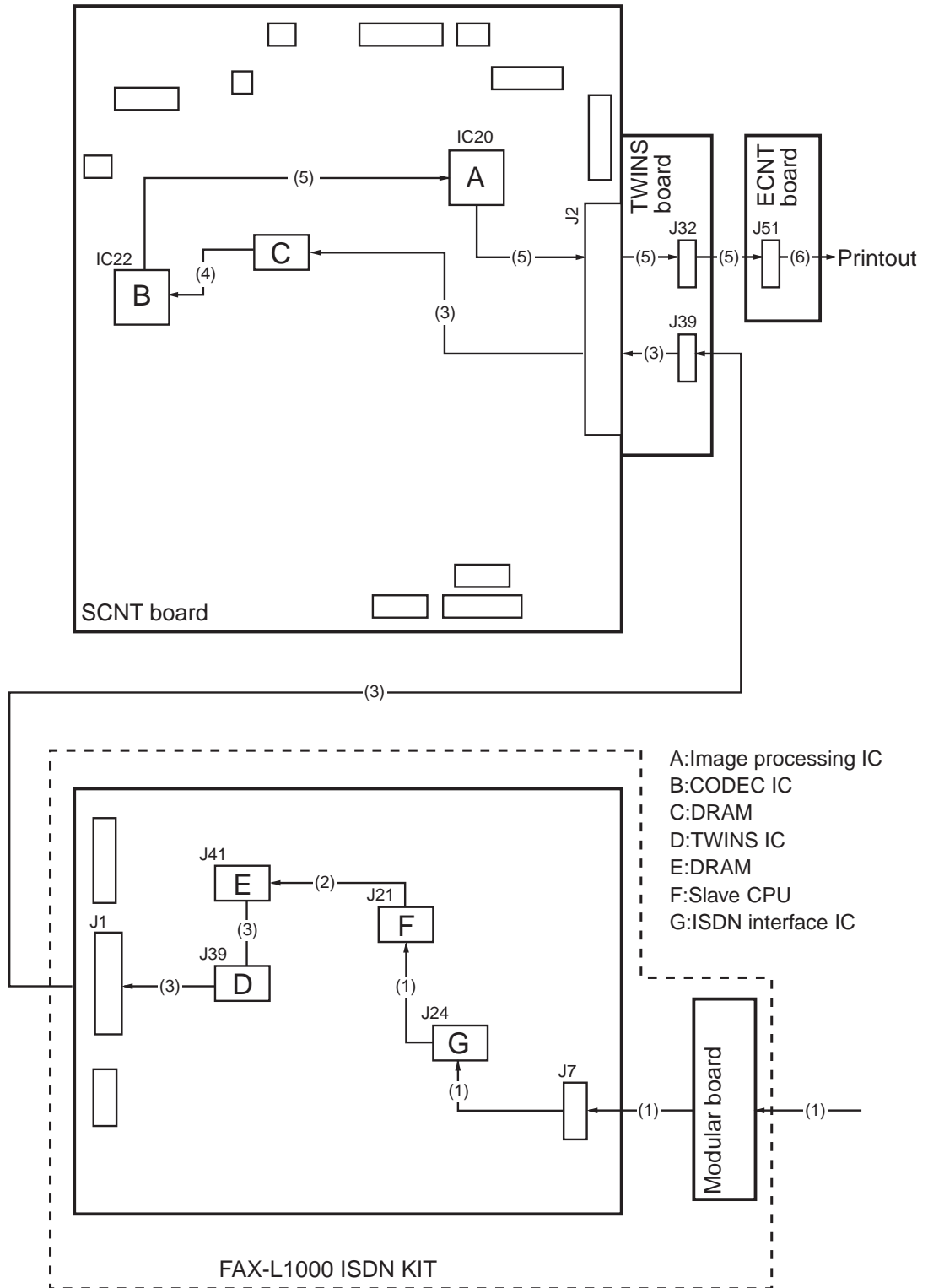

Figure 5-75 Reception Image Signal Flow

- (1) The received data is sent to the slave CPU from the modular board of the FAX-L1000 ISDN KIT through the ISDN interface IC.
- (2) The slave CPU converts it to MR encode data and stores it in the DRAM.
- (3) The MR encode data stored in the DRAM is transferred to the DRAM on the SCNT board through the TWINS board.
- (4) The CODEC IC on the SCNT board reads and combines the MR data stored in the DRAM by DMA transfer and writes raw data into the RAM in the CODEC IC. The data in the internal RAM is converted from parallel to serial by the printer interface of the IC and transferred to the image processing IC.
- (5) The image processing IC smoothens or scales down the data received from the CODEC IC for the LBP. The IC sends a print request signal (nPRNT) to the ECNT board interface, and when the printer becomes ready, the IC sends image data to the ECNT board through the TWINS board in synchronization with the vertical synchronizing signal (nVSYNC) and the horizontal synchronizing signal (nBD) coming from the ECNT board.
- (6) The ECNT board controls the printer and prints data based on the data from the SCNT board and information, such as paper size.

3.6.6 ISDN Protocol Messages

Main messages which are used in the communication protocols of Layer 2 - Layer 3 of the control channel's D-channel and Layer 2 - Layer 6 of the information channel's B-channel are listed.

a) D-channel messages

Layer 2

Message	Description	Remark
SABME	Set Asynchronous Balanced Mode Extended	The first thing sent when layer 2 is set.
UA	Unnumbered Acknowledge	A reply message for SABME, DISC.
DISC	Disconnect	Sent when layer 2 is released.

Layer 3 (Continue)

Message	Description	Remark
SETUP	Request for call settings	First sent by the calling party after setting layer 2 when making call settings. For the called party, it does not matter whether or not layer 2 is connected, SETUP will be done anyway. Then, if layer 2 has not been connected on the called party, it will be connected, and following that CONN, etc. will be sent.
SETUP ACK	SETUP Acknowledge	SETUP confirmation (request for additional information).
CALL PROC	Call Proceeding	This means that the calling party SETUP has been received by ISDN. It is an option message.
CONN	Connect	On the calling party, receives when the other terminal has responded. On the called party, sent for accepted SETUP when able to respond.
CONN ACK	Connect Acknowledge	On the calling party, sent for received CONN. On the called party, ISDN sent for the transmitted CONN.
ALERT	Alerting	On the calling party, receives when the other terminal is in a call. On the called party, sent when the user is in a call. It is an option message.
DISC	Disconnect	Sent when layer 3 is disconnected. Receives when disconnected from ISDN.

Layer 3 (Continue)

Message	Description	Remark
REL	Release	Sent when layer 3 is released or when DISC is received.
REL COMP	Release Complete	Sent when REL is received. ISDN sends with the transmitted REL.

b) B-channel messages

Layer 2

Message	Description	Remark
SABM	Set Asynchronous Balanced Mode	The first thing sent when layer 2 is set.
UA	Unnumbered Acknowledge	A reply message for SABM, DISC.
DISC	Disconnect	Sent when layer 2 is released.

Layer 3

Message	Description	Remark
CR	Call Request	Sent when layer 3 connects.
CN	Incoming Call	Received when layer 3 is connected.
CC	Call Connected	Reply for CR.
CA	Call Accepted	Reply for CN.
SQ	Restart Request	Sent before layer 3 connects.
SI	Restart Indication	Received before layer 3 is connected.
SF	Restart Confirmation	Reply for SQ/SI.
CQ	Clear Request	Sent when layer 3 disconnects.
CI	Clear Indication	Received when layer 3 is disconnected.
CF	Clear Confirmation	Reply for CQ/CI.

Layer 4

Message	Description	Remark
TCR	Transport Connection Request	Sent when layer 4 connects.
TCA	Transport Connection Accepted	Sent when TCR is received and layer 4 can be connected.
TCC	Transport Connection Clear	Sent when TCR is received and layer 4 cannot be connected.
TBR	Transport Block Reject	Sent when an error is found in layer 4 information.

Layer 5

Message	Description	Remark
CSS	Command Session Start	The first thing sent when layer 5 is started. Canon mode communication parameters are mainly added to this command.
RSSP	Response Session Start Positive	Sent when CSS is received and layer 5 can be started. Canon mode communication parameters are mainly added to this command.
RSSN	Response Session Start Negative	Sent when CSS is received and layer 5 cannot be started.
CSE	Command Session End	Sent when layer 5 is completed.
RSEP	Response Session End Positive	Reply for CSE.
CSCC	Command Session Change Control	Sent when it becomes layer 5's turn to transmit. This is used by polling communications, etc.
RSCCP	Response Session Change Control Positive	Reply for CSCC
CSUI	Command Session User Information	Indicates that there is a document procedure command.
RSUI	Response Session User Information	Indicates that there is a document procedure response.
CSA	Command Session Abort	Sent when the session procedure is halted.
RSAP	Response Session Abort Positive	Reply for CSA.
CDS	Command Document Start	Sent when the document procedure is started. States the size and resolution of pages that are able to be transmitted to CDE.
CDE	Command Document End	Sent when the document procedure is completed.
RDEP	Response Document End Positive	Reply for CDE.
CDPB	Command Document Page Boundary	Sent when it is shown that there is a gap between pages. A check point reference number is added as a parameter.
RDPBP	Response Document Page Boundary Positive	Sent when a page designated as CDPB is OK. A check point reference number is added as a parameter.
RDPBN	Response Document Page Boundary Negative	Sent when a page designated as CDPB is NG. A check point reference number is added as a parameter.

Layer 5 (Continue)

Message	Description	Remark
CDCL	Command Document Capability List	Indicates the function of the sending side (page size, resolution).
RDCLP	Response Document Capability List Positive	Indicates the function of the receiving side (page size, resolution).
CDR	Command Document Resynchronize	Sent when the document procedure on the sending side is halted.
RDRP	Response Document Resynchronize Positive	Reply for CDR.
CDD	Command Document Discard	Sent when the document procedure on the sending side is halted.
RDDP	Response Document Discard Positive	Reply for CDD.
RDGR	Response Document General Reject	Sent when a document procedure error is discovered on the receiving side.
CDUI	Command Document User Information	Indicates that there is data from layer 6 and higher (MMR).

Layer 6

Message	Description
P-START	Added to the front of the image data (page) as that page's attribute (paper, size, resolution) parameter.
P-END	Added to the end of the image data (page) for P-START.
PIX	The image data header, or the image data (MMR).

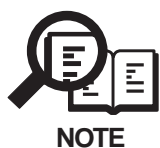

The message names (P-START, P-END, and PIX) are terms only used within Canon.

Please note that recommendations for these message names are not being considered.

c) D-Channel Standard Protocol

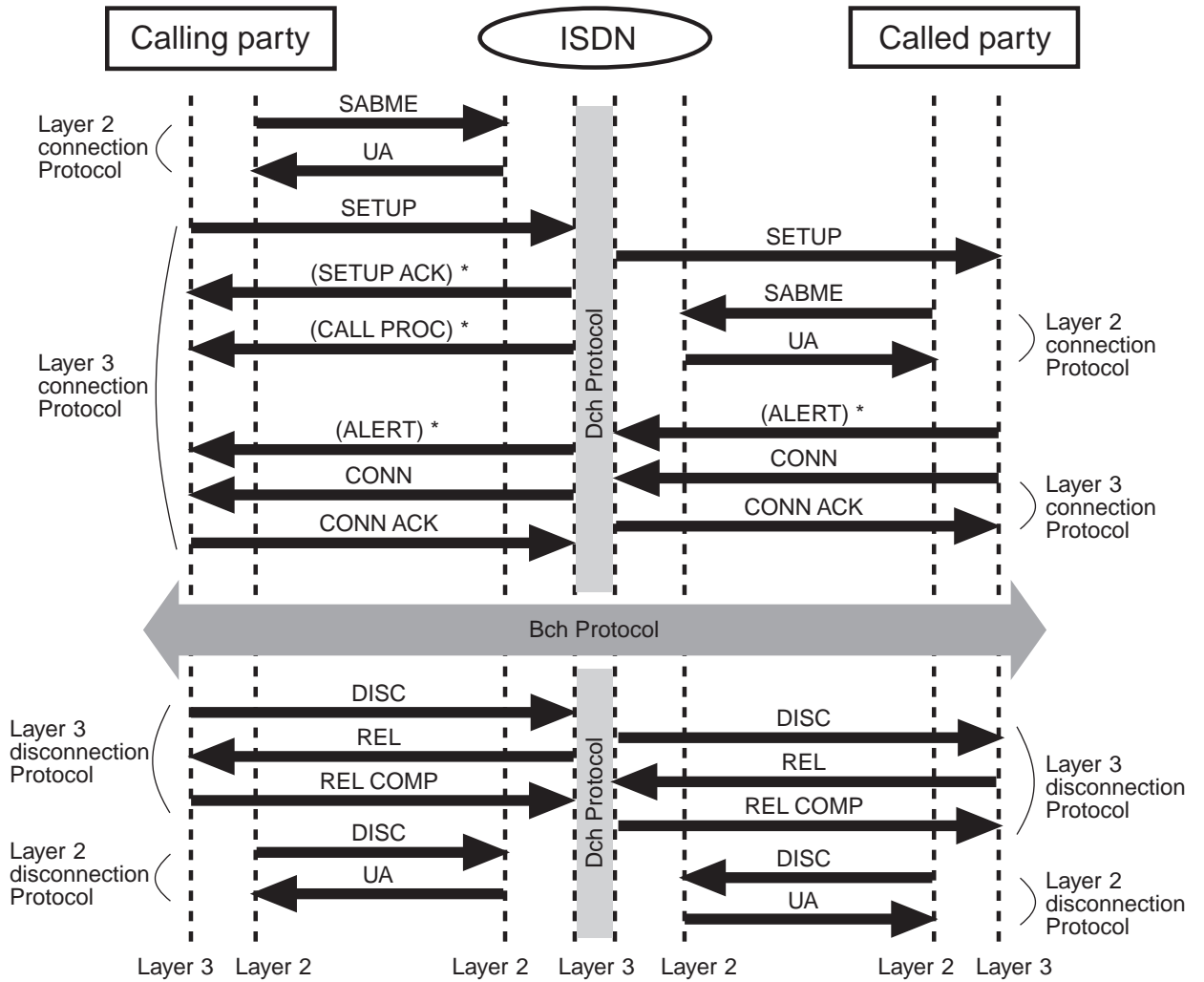

*: Messages in brackets are options.

Figure 5-76 D-Channel Protocol Flow

d) Information elements in the SETUP message

The SETUP message is one of the messages used in the D-channel Layer 3 communication protocol, as opposed to a network, and requires commencement of call settings. It is listed here, in the information element included in the main message, as a necessary element for the machine's service.

Sending Complete

Gives notification of completion of the Called Party Number destination. Addition of this required information is handled as an option in ITU-T recommendations. Additionally, the required information can be set as "Add/Do not Add" with a service switch on this machine.

Bearer Capability

Sets an outgoing G4 call to "unrestricted digital", an outgoing G3 call to "3.1kHz audio", and telephone to "speech". (There is no telephone in this machine.) It must be ensured that the information in question is added according to ITU-T recommendations.

Channel Identification

Designates the B-channel which will be used from now on. "B1 channel", "B2 channel", "any channel", and "no channel" will all be set. It must be ensured that the information in question is added according to ITU-T recommendations.

Progress Indicator

Notifies the channel generated for the call. Addition of this required information is handled as an option in ITU-T recommendations. Additionally, using a service switch, the progress contents can be set, and the required Progress Indicator information can be set as "Add/Do not Add" on this machine.

Calling Party Number

Sets the phone number of the calling party (=the machine itself). Addition of this required information is handled as an option in ITU-T recommendations.

Called Party Number

Sets the telephone number of the called party. Addition of this required information is handled as an option in ITU-T recommendations.

Low Layer Compatibility

Sets an outgoing G4 call to "unrestricted digital", an outgoing G3 call to "3.1kHz audio", and telephone to "speech". (There is no telephone in this machine.) Addition of this required information is handled as an option in ITU-T recommendations. Additionally, this machine can use a service switch to set the required information to "Add/Do not Add" in the SETUP message when calling with G4/G3.

High Layer Compatibility

With an outgoing G4 call, "G4 FAX" is set, with an outgoing G3 call, "G2/G3 FAX", and with telephone, "TEL". (There is no telephone in this machine.) Addition of this required information is handled as an option in ITU-T recommendations. Additionally, this machine can use a service switch to set the required information to "Add/Do not Add" in the SETUP message when making an outgoing G4/G3 call.

e) B-Channel Standard Protocol (G4)

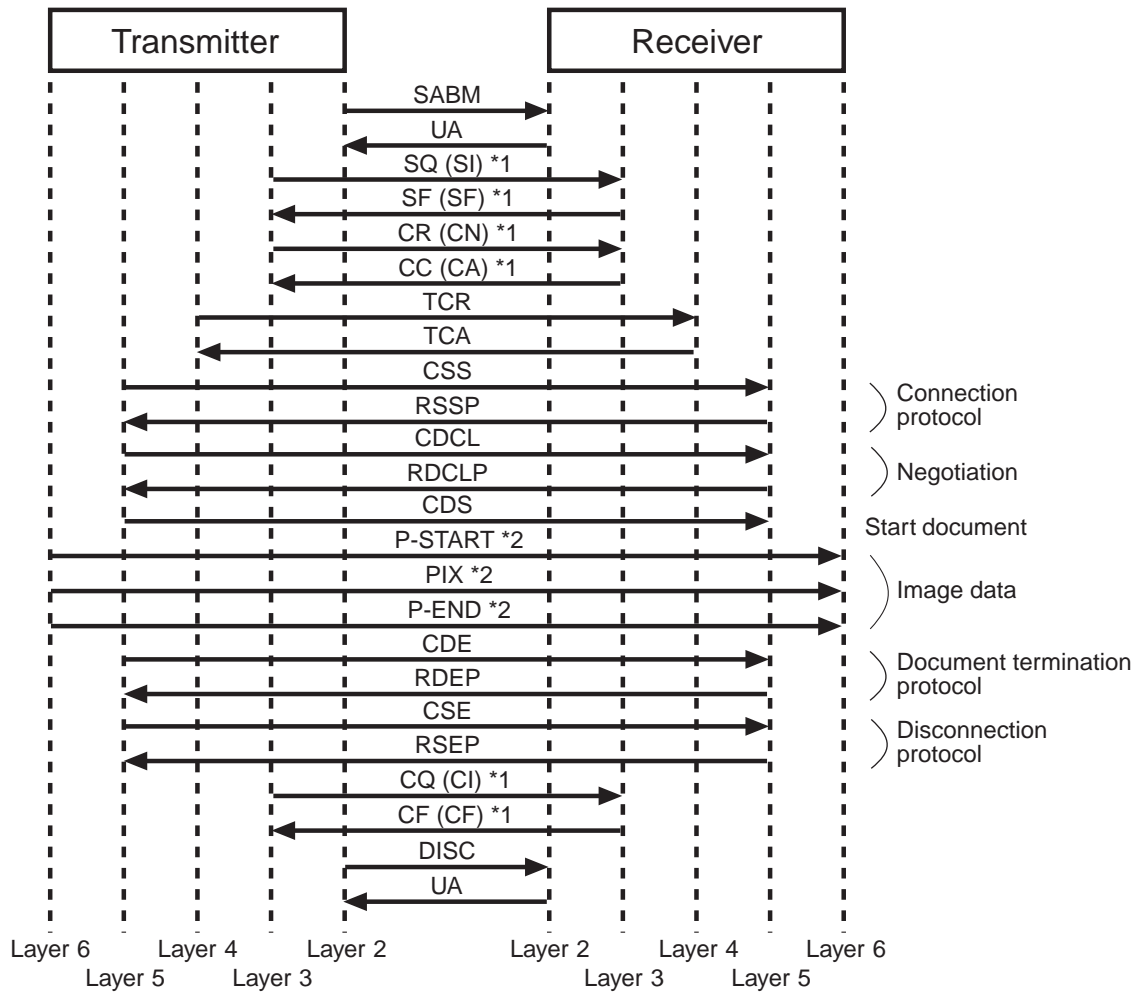

*1: The message seen by the receiving side is in brackets.
 *2: The messages are terms only used within Canon.
 Please note that recommendations for these message names are not being considered.

Figure 5-77 B-Channel Protocol Flow (G4)

f) B-Channel Standard Protocol (G3)

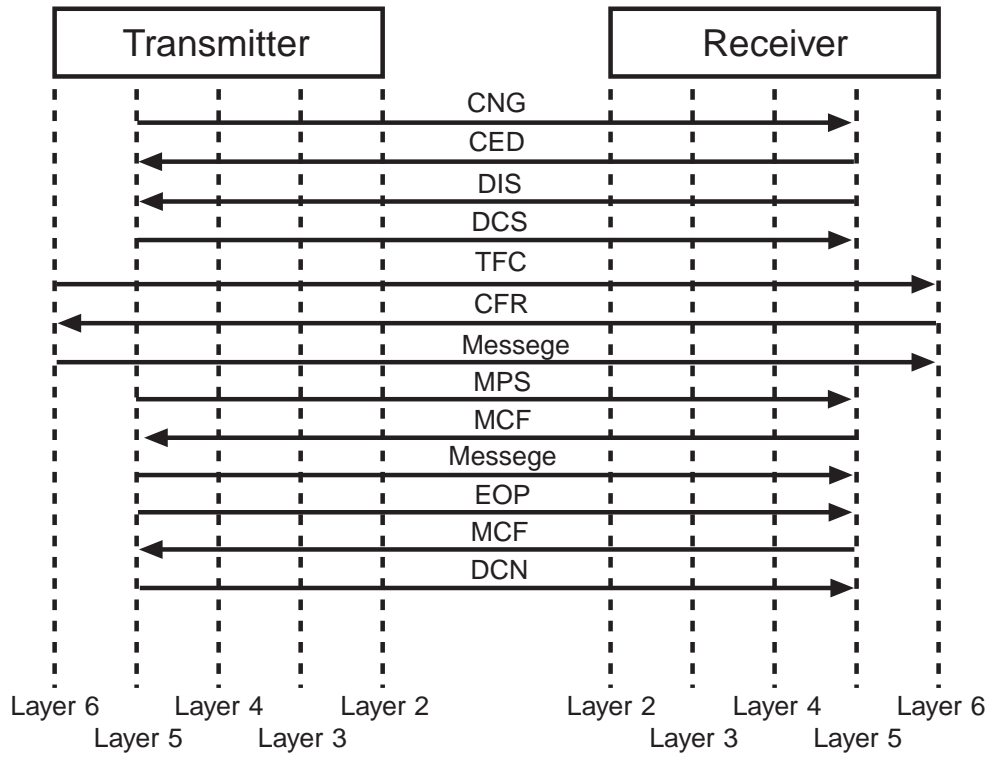

Figure 5-78 B-Channel Protocol Flow (G3)

3.6.7 Maintenance and service

a) Troubleshooting

The fax does not recognize the FAX-L1000 ISDN KIT even when it is attached properly.

- Solutions:**
- (1) Check that the kit is securely connected.
 - (2) Replace the kit.
 - (3) Replace the TWINS board.
 - (4) Replace the SCNT board.

b) D-channel error codes and B-channel error codes

• D-channel error codes (##1001~##1131)

D-channel protocol error codes are generated by taking the “cause number” notified which has been notified by the network and adding “1000” to it inside the machine. The required reason for the disconnection or restoration is assigned in the “cause number”, but even if the “cause number” notified by the each country’s network is identical, there will be times when the required reason for the disconnection or restoration will differ.

##1001 [TX/RX] a) Unallocated (unassigned) number

b) Invalid call reference value

- | | |
|----------------------|--|
| Cause a): | Indicated above |
| Solutions a): | <p>Remove the document and transmit/copy again.</p> <ol style="list-style-type: none"> (1) Re-check the phone number and try the call again. (2) Output a communications analysis list, and analyze it. (3) Make sure the 4 digits of the applicable error code are registered in <i>#4C ISDN BASIC, [G4/G3 Fallback]</i> and <i>[Speech Fallback]</i>. (4) Take countermeasures as outlined in <i>D-channel connection error in this Chapter, 3.6.6 Maintenance and service, c) Communication problems.</i> (5) Make an inquiry to the maker of the Switching equipment. |
| Cause b): | Indicated above |
| Solutions b): | <ol style="list-style-type: none"> (1) Re-transmit. (2) Output a communications analysis list, and analyze it. (3) Make sure the 4 digits of the applicable error code are registered in <i>#4C ISDN BASIC, [G4/G3 Fallback]</i> and <i>[Speech Fallback]</i>. (4) Take countermeasures as outlined in <i>D-channel connection error in this Chapter, 3.6.6 Maintenance and service, c) Communication problems.</i> (5) Make an inquiry to the maker of the Switching equipment. |

##1002 [TX/RX] No route to specified transit network.

- Cause:** Indicated above
- Solutions:**
- (1) Re-check the method of connection to the designated relay network.
 - (2) Output a communications analysis list, and analyze it.
 - (3) Make sure the 4 digits of the applicable error code are registered in *#4C ISDN BASIC, [G4/G3 Fallback]* and *[Speech Fallback]*.
 - (4) Take countermeasures as outlined in *D-channel connection error in this Chapter, 3.6.6 Maintenance and service, c) Communication problems.*
 - (5) Make an inquiry to the maker of the Switching equipment.

##1003 [TX/RX] a) No route to destination.

b) Designated bearer service not implemented.

- Cause a):** Indicated above
- Solutions a):**
- (1) Re-check the phone number and try the call again.
 - (2) Output a communications analysis list, and analyze it.
 - (3) Make sure the 4 digits of the applicable error code are registered in *#4C ISDN BASIC, [G4/G3 Fallback]* and *[Speech Fallback]*.
 - (4) Take countermeasures as outlined in *D-channel connection error in this Chapter, 3.6.6 Maintenance and service, c) Communication problems.*
 - (5) Make an inquiry to the maker of the Switching equipment.

Cause b): Indicated above

- Solutions b):**
- (1) Re-check the designated bearer service.
 - (2) Output a communications analysis list, and analyze it.
 - (3) Make sure the 4 digits of the applicable error code are registered in *#4C ISDN BASIC, [G4/G3 Fallback]* and *[Speech Fallback]*.
 - (4) Take countermeasures as outlined in *D-channel connection error in this Chapter, 3.6.6 Maintenance and service, c) Communication problems.*
 - (5) Make an inquiry to the maker of the Switching equipment.

##1006 [TX/RX] Channel unacceptable.

- Cause:** Indicated above
- Solutions:**
- (1) Wait a while and then transmit, because the other terminal is in the middle of a transmission.
 - (2) Output a communications analysis list, and analyze it.
 - (3) Make sure the 4 digits of the applicable error code are registered in *#4C ISDN BASIC, [G4/G3 Fallback]* and *[Speech Fallback]*.
 - (4) Take countermeasures as outlined in *D-channel connection error in this Chapter, 3.6.6 Maintenance and service, c) Communication problems.*
 - (5) Make an inquiry to the maker of the Switching equipment.

**##1007 [TX/RX] a) Call awarded and being delivered in an established channel.
b) Call identity not exist.**

-
- Cause a):** Indicated above
- Solutions a):**
- (1) Wait a while, then re-establish communication.
 - (2) Output a communications analysis list, and analyze it.
 - (3) Make sure the 4 digits of the applicable error code are registered in *#4C ISDN BASIC, [G4/G3 Fallback]* and *[Speech Fallback]*.
 - (4) Take countermeasures as outlined in *D-channel connection error in this Chapter, 3.6.6 Maintenance and service, c) Communication problems.*
 - (5) Make an inquiry to the maker of the Switching equipment.
- Cause b):** Indicated above
- Solutions b):**
- (1) Re-transmit.
 - (2) Output a communications analysis list, and analyze it.
 - (3) Make sure the 4 digits of the applicable error code are registered in *#4C ISDN BASIC, [G4/G3 Fallback]* and *[Speech Fallback]*.
 - (4) Take countermeasures as outlined in *D-channel connection error in this Chapter, 3.6.6 Maintenance and service, c) Communication problems.*
 - (5) Make an inquiry to the maker of the Switching equipment.

##1008 [TX/RX] Call identity does not belong to a parked connection.

-
- Cause:** Indicated above
- Solutions:**
- (1) Re-establish communication.
 - (2) Output a communications analysis list, and analyze it.
 - (3) Make sure the 4 digits of the applicable error code are registered in *#4C ISDN BASIC, [G4/G3 Fallback]* and *[Speech Fallback]*.
 - (4) Take countermeasures as outlined in *D-channel connection error in this Chapter, 3.6.6 Maintenance and service, c) Communication problems.*
 - (5) Make an inquiry to the maker of the Switching equipment.

##1010 [TX/RX] Unknown Facility-Code (Code for service characteristic).

-
- Cause:** Indicated above
- Solutions:**
- (1) Re-transmit.
 - (2) Output a communications analysis list, and analyze it.
 - (3) Make sure the 4 digits of the applicable error code are registered in *#4C ISDN BASIC, [G4/G3 Fallback]* and *[Speech Fallback]*.
 - (4) Take countermeasures as outlined in *D-channel connection error in this Chapter, 3.6.6 Maintenance and service, c) Communication problems.*
 - (5) Make an inquiry to the maker of the Switching equipment.

**##1016 [TX/RX] a) Normal call clearing user busy.
b) No basic channel free.**

Cause a): Indicated above

- Solutions a):**
- (1) Re-establish communication.
 - (2) Output a communications analysis list, and analyze it.
 - (3) Make sure the 4 digits of the applicable error code are registered in *#4C ISDN BASIC, [G4/G3 Fallback]* and *[Speech Fallback]*.
 - (4) Take countermeasures as outlined in *D-channel connection error in this Chapter, 3.6.6 Maintenance and service, c) Communication problems.*
 - (5) Make an inquiry to the maker of the Switching equipment.

Cause b): Indicated above

- Solutions b):**
- (1) Re-transmit.
 - (2) Output a communications analysis list, and analyze it.
 - (3) Make sure the 4 digits of the applicable error code are registered in *#4C ISDN BASIC, [G4/G3 Fallback]* and *[Speech Fallback]*.
 - (4) Take countermeasures as outlined in *D-channel connection error in this Chapter, 3.6.6 Maintenance and service, c) Communication problems.*
 - (5) Make an inquiry to the maker of the Switching equipment.

**##1017 [TX/RX] a) User busy.
b) No approval for requested service characteristic.**

Cause a): Indicated above

- Solutions a):**
- (1) Wait a while, then re-transmit.
 - (2) Output a communications analysis list, and analyze it.
 - (3) Make sure the 4 digits of the applicable error code are registered in *#4C ISDN BASIC, [G4/G3 Fallback]* and *[Speech Fallback]*.
 - (4) Take countermeasures as outlined in *D-channel connection error in this Chapter, 3.6.6 Maintenance and service, c) Communication problems.*
 - (5) Make an inquiry to the maker of the Switching equipment.

Cause b): Indicated above

- Solutions b):**
- (1) Re-transmit.
 - (2) Output a communications analysis list, and analyze it.
 - (3) Make sure the 4 digits of the applicable error code are registered in *#4C ISDN BASIC, [G4/G3 Fallback]* and *[Speech Fallback]*.
 - (4) Take countermeasures as outlined in *D-channel connection error in this Chapter, 3.6.6 Maintenance and service, c) Communication problems.*
 - (5) Make an inquiry to the maker of the Switching equipment.

##1018 [TX/RX] No user responding

Cause: Indicated above

- Solutions:**
- (1) Re-transmit.
 - (2) Make sure that the other party's machine is plugged in and connected to the line.
 - (3) Output a communications analysis list, and analyze it.
 - (4) Make sure the 4 digits of the applicable error code are registered in *#4C ISDN BASIC, [G4/G3 Fallback]* and *[Speech Fallback]*.
 - (5) Take countermeasures as outlined in *D-channel connection error in this Chapter, 3.6.6 Maintenance and service, c) Communication problems.*
 - (6) Make an inquiry to the maker of the Switching equipment.

##1019 [TX/RX] No answer from user (user alerted).

Cause: Indicated above

- Solutions:**
- (1) Wait a while, then re-transmit.
 - (2) Output a communications analysis list, and analyze it.
 - (3) Make sure the 4 digits of the applicable error code are registered in *#4C ISDN BASIC, [G4/G3 Fallback]* and *[Speech Fallback]*.
 - (4) Take countermeasures as outlined in *D-channel connection error in this Chapter, 3.6.6 Maintenance and service, c) Communication problems.*
 - (5) Make an inquiry to the maker of the Switching equipment.

##1021 [TX/RX] Call rejected

Cause: Indicated above

- Solutions:**
- (1) Re-transmit.
 - (2) Output a communications analysis list, and analyze it.
 - (3) Make sure the 4 digits of the applicable error code are registered in *#4C ISDN BASIC, [G4/G3 Fallback]* and *[Speech Fallback]*.
 - (4) Take countermeasures as outlined in *D-channel connection error in this Chapter, 3.6.6 Maintenance and service, c) Communication problems.*
 - (5) Make an inquiry to the maker of the Switching equipment.

##1022 [TX/RX] Number changed.

Cause: Indicated above

- Solutions:**
- (1) Re-check the phone number and try the call again.
 - (2) Output a communications analysis list, and analyze it.
 - (3) Make sure the 4 digits of the applicable error code are registered in *#4C ISDN BASIC, [G4/G3 Fallback]* and *[Speech Fallback]*.
 - (4) Take countermeasures as outlined in *D-channel connection error in this Chapter, 3.6.6 Maintenance and service, c) Communication problems.*
 - (5) Make an inquiry to the maker of the Switching equipment.

##1026 [TX/RX] Non-selected user cleaning.

- Cause:** Indicated above
- Solutions:**
- (1) Re-establish communication.
 - (2) Output a communications analysis list, and analyze it.
 - (3) Make sure the 4 digits of the applicable error code are registered in *#4C ISDN BASIC, [G4/G3 Fallback]* and *[Speech Fallback]*.
 - (4) Take countermeasures as outlined in *D-channel connection error in this Chapter, 3.6.6 Maintenance and service, c) Communication problems.*
 - (5) Make an inquiry to the maker of the Switching equipment.

##1027 [TX/RX] Destination out of order.

- Cause:** Indicated above
- Solutions:**
- (1) Inquire as to whether or not the other party's machine can be used.
 - (2) Output a communications analysis list, and analyze it.
 - (3) Make sure the 4 digits of the applicable error code are registered in *#4C ISDN BASIC, [G4/G3 Fallback]* and *[Speech Fallback]*.
 - (4) Take countermeasures as outlined in *D-channel connection error in this Chapter, 3.6.6 Maintenance and service, c) Communication problems.*
 - (5) Make an inquiry to the maker of the Switching equipment.

##1028 [TX/RX] Invalid number format.

- Cause:** Indicated above
- Solutions:**
- (1) Check the phone number, and re-transmit.
 - (2) Output a communications analysis list, and analyze it.
 - (3) Make sure the 4 digits of the applicable error code are registered in *#4C ISDN BASIC, [G4/G3 Fallback]* and *[Speech Fallback]*.
 - (4) Take countermeasures as outlined in *D-channel connection error in this Chapter, 3.6.6 Maintenance and service, c) Communication problems.*
 - (5) Make an inquiry to the maker of the Switching equipment.

##1029 [TX/RX] Facility rejected.

- Cause:** Indicated above
- Solutions:**
- (1) Re-check the designated service contract.
 - (2) Output a communications analysis list, and analyze it.
 - (3) Make sure the 4 digits of the applicable error code are registered in *#4C ISDN BASIC, [G4/G3 Fallback]* and *[Speech Fallback]*.
 - (4) Take countermeasures as outlined in *D-channel connection error in this Chapter, 3.6.6 Maintenance and service, c) Communication problems.*
 - (5) Make an inquiry to the maker of the Switching equipment.

##1030 [TX/RX] Response to status enquiry.

- Cause:** Indicated above
- Solutions:**
- (1) Re-establish communication.
 - (2) Output a communications analysis list, and analyze it.
 - (3) Make sure the 4 digits of the applicable error code are registered in *#4C ISDN BASIC, [G4/G3 Fallback]* and *[Speech Fallback]*.
 - (4) Take countermeasures as outlined in *D-channel connection error in this Chapter, 3.6.6 Maintenance and service, c) Communication problems.*
 - (5) Make an inquiry to the maker of the Switching equipment.

##1031 [TX/RX] Normal, unspecified.

- Cause:** Indicated above
- Solutions:**
- (1) Re-establish communication.
 - (2) Output a communications analysis list, and analyze it.
 - (3) Make sure the 4 digits of the applicable error code are registered in *#4C ISDN BASIC, [G4/G3 Fallback]* and *[Speech Fallback]*.
 - (4) Take countermeasures as outlined in *D-channel connection error in this Chapter, 3.6.6 Maintenance and service, c) Communication problems.*
 - (5) Make an inquiry to the maker of the Switching equipment.

##1032 [TX/RX] Look of outgoing connection

- Cause:** Indicated above
- Solutions:**
- (1) Re-establish communication.
 - (2) Output a communications analysis list, and analyze it.
 - (3) Make sure the 4 digits of the applicable error code are registered in *#4C ISDN BASIC, [G4/G3 Fallback]* and *[Speech Fallback]*.
 - (4) Take countermeasures as outlined in *D-channel connection error in this Chapter, 3.6.6 Maintenance and service, c) Communication problems.*
 - (5) Make an inquiry to the maker of the Switching equipment.

##1033 [TX/RX] Other party is busy

- Cause:** Indicated above
- Solutions:**
- (1) Re-transmit.
 - (2) Output a communications analysis list, and analyze it.
 - (3) Make sure the 4 digits of the applicable error code are registered in *#4C ISDN BASIC, [G4/G3 Fallback]* and *[Speech Fallback]*.
 - (4) Take countermeasures as outlined in *D-channel connection error in this Chapter, 3.6.6 Maintenance and service, c) Communication problems.*
 - (5) Make an inquiry to the maker of the Switching equipment.

**##1034 [TX/RX] a) No circuit/channel available
b) No access to a closed user group.**

- Cause a):** Indicated above
- Solutions a):**
- (1) Wait a while, then re-transmit, because the other party's machine is busy.
 - (2) Output a communications analysis list, and analyze it.
 - (3) Make sure the 4 digits of the applicable error code are registered in *#4C ISDN BASIC, [G4/G3 Fallback]* and *[Speech Fallback]*.
 - (4) Take countermeasures as outlined in *D-channel connection error in this Chapter, 3.6.6 Maintenance and service, c) Communication problems.*
 - (5) Make an inquiry to the maker of the Switching equipment.
- Cause b):** Indicated above
- Solutions b):**
- (1) Re-establish communication.
 - (2) Output a communications analysis list, and analyze it.
 - (3) Make sure the 4 digits of the applicable error code are registered in *#4C ISDN BASIC, [G4/G3 Fallback]* and *[Speech Fallback]*.
 - (4) Take countermeasures as outlined in *D-channel connection error in this Chapter, 3.6.6 Maintenance and service, c) Communication problems.*
 - (5) Make an inquiry to the maker of the Switching equipment.

##1035 [TX/RX] Closed user group does not exist.

- Cause:** Indicated above
- Solutions:**
- (1) Re-confirm with the other party, and then re-transmit.
 - (2) Output a communications analysis list, and analyze it.
 - (3) Make sure the 4 digits of the applicable error code are registered in *#4C ISDN BASIC, [G4/G3 Fallback]* and *[Speech Fallback]*.
 - (4) Take countermeasures as outlined in *D-channel connection error in this Chapter, 3.6.6 Maintenance and service, c) Communication problems.*
 - (5) Make an inquiry to the maker of the Switching equipment.

##1038 [TX/RX] Network out of order

- Cause:** Indicated above
- Solutions:**
- (1) Wait a while and then re-transmit, because there is a network obstacle has occurred.
 - (2) Output a communications analysis list, and analyze it.
 - (3) Make sure the 4 digits of the applicable error code are registered in *#4C ISDN BASIC, [G4/G3 Fallback]* and *[Speech Fallback]*.
 - (4) Take countermeasures as outlined in *D-channel connection error in this Chapter, 3.6.6 Maintenance and service, c) Communication problems.*
 - (5) Make an inquiry to the maker of the Switching equipment.

##1041 [TX/RX] Temporary failure

Cause: Indicated above

- Solutions:**
- (1) Wait a while, then re-establish communication.
 - (2) Output a communications analysis list, and analyze it.
 - (3) Make sure the 4 digits of the applicable error code are registered in *#4C ISDN BASIC, [G4/G3 Fallback]* and *[Speech Fallback]*.
 - (4) Take countermeasures as outlined in *D-channel connection error in this Chapter, 3.6.6 Maintenance and service, c) Communication problems.*
 - (5) Make an inquiry to the maker of the Switching equipment.

##1042 [TX/RX] Switching equipment congestion

Cause: Indicated above

- Solutions:**
- (1) Wait a while, then re-establish communication.
 - (2) Output a communications analysis list, and analyze it.
 - (3) Make sure the 4 digits of the applicable error code are registered in *#4C ISDN BASIC, [G4/G3 Fallback]* and *[Speech Fallback]*.
 - (4) Take countermeasures as outlined in *D-channel connection error in this Chapter, 3.6.6 Maintenance and service, c) Communication problems.*
 - (5) Make an inquiry to the maker of the Switching equipment.

##1043 [TX/RX] Access information discarded

Cause: Indicated above

- Solutions:**
- (1) Re-establish communication.
 - (2) Output a communications analysis list, and analyze it.
 - (3) Make sure the 4 digits of the applicable error code are registered in *#4C ISDN BASIC, [G4/G3 Fallback]* and *[Speech Fallback]*.
 - (4) Take countermeasures as outlined in *D-channel connection error in this Chapter, 3.6.6 Maintenance and service, c) Communication problems.*
 - (5) Make an inquiry to the maker of the Switching equipment.

##1044 [TX/RX] Requested circuit/channel not available

Cause: Indicated above

- Solutions:**
- (1) Re-transmit.
 - (2) Output a communications analysis list, and analyze it.
 - (3) Make sure the 4 digits of the applicable error code are registered in *#4C ISDN BASIC, [G4/G3 Fallback]* and *[Speech Fallback]*.
 - (4) Take countermeasures as outlined in *D-channel connection error in this Chapter, 3.6.6 Maintenance and service, c) Communication problems.*
 - (5) Make an inquiry to the maker of the Switching equipment.

##1047 [TX/RX] Resources unavailable, unspecified

- Cause:** Indicated above
- Solutions:**
- (1) Re-establish communication.
 - (2) Output a communications analysis list, and analyze it.
 - (3) Make sure the 4 digits of the applicable error code are registered in *#4C ISDN BASIC, [G4/G3 Fallback]* and *[Speech Fallback]*.
 - (4) Take countermeasures as outlined in *D-channel connection error in this Chapter, 3.6.6 Maintenance and service, c) Communication problems.*
 - (5) Make an inquiry to the maker of the Switching equipment.

##1049 [TX/RX] Quality of service unavailable

- Cause:** Indicated above
- Solutions:**
- (1) Re-establish communication.
 - (2) Output a communications analysis list, and analyze it.
 - (3) Make sure the 4 digits of the applicable error code are registered in *#4C ISDN BASIC, [G4/G3 Fallback]* and *[Speech Fallback]*.
 - (4) Take countermeasures as outlined in *D-channel connection error in this Chapter, 3.6.6 Maintenance and service, c) Communication problems.*
 - (5) Make an inquiry to the maker of the Switching equipment.

##1050 [TX/RX] Requested facility not subscribed

- Cause:** Indicated above
- Solutions:**
- (1) Re-check the contract, and re-establish communication.
 - (2) Output a communications analysis list, and analyze it.
 - (3) Make sure the 4 digits of the applicable error code are registered in *#4C ISDN BASIC, [G4/G3 Fallback]* and *[Speech Fallback]*.
 - (4) Take countermeasures as outlined in *D-channel connection error in this Chapter, 3.6.6 Maintenance and service, c) Communication problems.*
 - (5) Make an inquiry to the maker of the Switching equipment.

##1053 [TX/RX] No connection inside the net possible

- Cause:** Indicated above
- Solutions:**
- (1) Re-establish communication.
 - (2) Output a communications analysis list, and analyze it.
 - (3) Make sure the 4 digits of the applicable error code are registered in *#4C ISDN BASIC, [G4/G3 Fallback]* and *[Speech Fallback]*.
 - (4) Take countermeasures as outlined in *D-channel connection error in this Chapter, 3.6.6 Maintenance and service, c) Communication problems.*
 - (5) Make an inquiry to the maker of the Switching equipment.

##1056 [TX/RX] The calling number of the wished connection has been changed

- Cause:** Indicated above
- Solutions:**
- (1) Re-check the telephone number, then re-transmit.
 - (2) Output a communications analysis list, and analyze it.
 - (3) Make sure the 4 digits of the applicable error code are registered in *#4C ISDN BASIC, [G4/G3 Fallback]* and *[Speech Fallback]*.
 - (4) Take countermeasures as outlined in *D-channel connection error in this Chapter, 3.6.6 Maintenance and service, c) Communication problems.*
 - (5) Make an inquiry to the maker of the Switching equipment.

##1057 [TX/RX] a) Bearer capability not authorized

b) Called terminal not operational

- Cause a):** Indicated above
- Solutions a):**
- (1) Re-check the contract, and re-transmit.
 - (2) Output a communications analysis list, and analyze it.
 - (3) Make sure the 4 digits of the applicable error code are registered in *#4C ISDN BASIC, [G4/G3 Fallback]* and *[Speech Fallback]*.
 - (4) Take countermeasures as outlined in *D-channel connection error in this Chapter, 3.6.6 Maintenance and service, c) Communication problems.*
 - (5) Make an inquiry to the maker of the Switching equipment.
- Cause b):** Indicated above
- Solutions b):**
- (1) Inquire to the other party whether the terminal can be used, then re-transmit.
 - (2) Output a communications analysis list, and analyze it.
 - (3) Make sure the 4 digits of the applicable error code are registered in *#4C ISDN BASIC, [G4/G3 Fallback]* and *[Speech Fallback]*.
 - (4) Take countermeasures as outlined in *D-channel connection error in this Chapter, 3.6.6 Maintenance and service, c) Communication problems.*
 - (5) Make an inquiry to the maker of the Switching equipment.

##1058 [TX/RX] a) Bearer capability not presently available

b) Call has not been accessed, break down through time-out

Cause a): Indicated above

- Solutions a):**
- (1) Re-check the contract, and re-transmit.
 - (2) Output a communications analysis list, and analyze it.
 - (3) Make sure the 4 digits of the applicable error code are registered in *#4C ISDN BASIC, [G4/G3 Fallback]* and *[Speech Fallback]*.
 - (4) Take countermeasures as outlined in *D-channel connection error in this Chapter, 3.6.6 Maintenance and service, c) Communication problems.*
 - (5) Make an inquiry to the maker of the Switching equipment.

Cause b): Indicated above

- Solutions b):**
- (1) Re-check the telephone number, then re-establish communication.
 - (2) Output a communications analysis list, and analyze it.
 - (3) Make sure the 4 digits of the applicable error code are registered in *#4C ISDN BASIC, [G4/G3 Fallback]* and *[Speech Fallback]*.
 - (4) Take countermeasures as outlined in *D-channel connection error in this Chapter, 3.6.6 Maintenance and service, c) Communication problems.*
 - (5) Make an inquiry to the maker of the Switching equipment.

##1059 [TX/RX] Called party is busy (all B-channel are occupied)

Cause: Indicated above

- Solutions:**
- (1) Wait a while, then re-transmit.
 - (2) Output a communications analysis list, and analyze it.
 - (3) Make sure the 4 digits of the applicable error code are registered in *#4C ISDN BASIC, [G4/G3 Fallback]* and *[Speech Fallback]*.
 - (4) Take countermeasures as outlined in *D-channel connection error in this Chapter, 3.6.6 Maintenance and service, c) Communication problems.*
 - (5) Make an inquiry to the maker of the Switching equipment.

##1060 [TX/RX] Disconnection from network

Cause: Indicated above

- Solutions:**
- (1) Re-check the phone number and try the call again.
 - (2) Output a communications analysis list, and analyze it.
 - (3) Make sure the 4 digits of the applicable error code are registered in *#4C ISDN BASIC, [G4/G3 Fallback]* and *[Speech Fallback]*.
 - (4) Take countermeasures as outlined in *D-channel connection error in this Chapter, 3.6.6 Maintenance and service, c) Communication problems.*
 - (5) Make an inquiry to the maker of the Switching equipment.

##1061 [TX/RX] Called party is closed or does not support the service

- Cause:** Indicated above
- Solutions:**
- (1) Designated number/Re-check the contract, and re-transmit.
 - (2) Output a communications analysis list, and analyze it.
 - (3) Make sure the 4 digits of the applicable error code are registered in *#4C ISDN BASIC, [G4/G3 Fallback]* and *[Speech Fallback]*.
 - (4) Take countermeasures as outlined in *D-channel connection error in this Chapter, 3.6.6 Maintenance and service, c) Communication problems.*
 - (5) Make an inquiry to the maker of the Switching equipment.

**##1062 [TX/RX] a) Active rejection of connection through the called party
b) Disconnection from network**

- Cause a):** Indicated above
- Solutions a):**
- (1) Re-check the telephone number, then re-transmit.
 - (2) Output a communications analysis list, and analyze it.
 - (3) Make sure the 4 digits of the applicable error code are registered in *#4C ISDN BASIC, [G4/G3 Fallback]* and *[Speech Fallback]*.
 - (4) Take countermeasures as outlined in *D-channel connection error in this Chapter, 3.6.6 Maintenance and service, c) Communication problems.*
 - (5) Make an inquiry to the maker of the Switching equipment.
- Cause b):** Indicated above
- Solutions b):**
- (1) Re-check the telephone number, then re-establish communication.
 - (2) Output a communications analysis list, and analyze it.
 - (3) Make sure the 4 digits of the applicable error code are registered in *#4C ISDN BASIC, [G4/G3 Fallback]* and *[Speech Fallback]*.
 - (4) Take countermeasures as outlined in *D-channel connection error in this Chapter, 3.6.6 Maintenance and service, c) Communication problems.*
 - (5) Make an inquiry to the maker of the Switching equipment.

##1063 [TX/RX] Service or option not available, unspecified.

- Cause:** Indicated above
- Solutions:**
- (1) Re-check the designated service contract, and re-establish communication.
 - (2) Output a communications analysis list, and analyze it.
 - (3) Make sure the 4 digits of the applicable error code are registered in *#4C ISDN BASIC, [G4/G3 Fallback]* and *[Speech Fallback]*.
 - (4) Take countermeasures as outlined in *D-channel connection error in this Chapter, 3.6.6 Maintenance and service, c) Communication problems.*
 - (5) Make an inquiry to the maker of the Switching equipment.

##1065 [TX/RX] Bearer capability not implemented

Cause: Indicated above

- Solutions:**
- (1) Re-check the designated service contract, and re-transmit.
 - (2) Output a communications analysis list, and analyze it.
 - (3) Make sure the 4 digits of the applicable error code are registered in *#4C ISDN BASIC, [G4/G3 Fallback]* and *[Speech Fallback]*.
 - (4) Take countermeasures as outlined in *D-channel connection error in this Chapter, 3.6.6 Maintenance and service, c) Communication problems.*
 - (5) Make an inquiry to the maker of the Switching equipment.

##1066 [TX/RX] Non-supplied channel classification designated

Cause: Indicated above

- Solutions:**
- (1) Re-check the designated service contract, and re-transmit.
 - (2) Output a communications analysis list, and analyze it.
 - (3) Make sure the 4 digits of the applicable error code are registered in *#4C ISDN BASIC, [G4/G3 Fallback]* and *[Speech Fallback]*.
 - (4) Take countermeasures as outlined in *D-channel connection error in this Chapter, 3.6.6 Maintenance and service, c) Communication problems.*
 - (5) Make an inquiry to the maker of the Switching equipment.

##1069 [TX/RX] Channel type not implemented

Cause: Indicated above

- Solutions:**
- (1) Re-check the designated service contract, and re-transmit.
 - (2) Output a communications analysis list, and analyze it.
 - (3) Make sure the 4 digits of the applicable error code are registered in *#4C ISDN BASIC, [G4/G3 Fallback]* and *[Speech Fallback]*.
 - (4) Take countermeasures as outlined in *D-channel connection error in this Chapter, 3.6.6 Maintenance and service, c) Communication problems.*
 - (5) Make an inquiry to the maker of the Switching equipment.

##1070 [TX/RX] Only restricted digital information bearer capability is available

Cause: Indicated above

- Solutions:**
- (1) Re-transmit.
 - (2) Output a communications analysis list, and analyze it.
 - (3) Make sure the 4 digits of the applicable error code are registered in *#4C ISDN BASIC, [G4/G3 Fallback]* and *[Speech Fallback]*.
 - (4) Take countermeasures as outlined in *D-channel connection error in this Chapter, 3.6.6 Maintenance and service, c) Communication problems.*
 - (5) Make an inquiry to the maker of the Switching equipment.

##1079 [TX/RX] Service or option not implemented, unspecified

- Cause:** Indicated above
- Solutions:**
- (1) Re-check the designated service contract, and re-establish communication.
 - (2) Output a communications analysis list, and analyze it.
 - (3) Make sure the 4 digits of the applicable error code are registered in *#4C ISDN BASIC, [G4/G3 Fallback]* and *[Speech Fallback]*.
 - (4) Take countermeasures as outlined in *D-channel connection error in this Chapter, 3.6.6 Maintenance and service, c) Communication problems*.
 - (5) Make an inquiry to the maker of the Switching equipment.

##1081 [TX/RX] Invalid call reference value

- Cause:** Indicated above
- Solutions:**
- (1) Re-establish communication.
 - (2) Output a communications analysis list, and analyze it.
 - (3) Make sure the 4 digits of the applicable error code are registered in *#4C ISDN BASIC, [G4/G3 Fallback]* and *[Speech Fallback]*.
 - (4) Take countermeasures as outlined in *D-channel connection error in this Chapter, 3.6.6 Maintenance and service, c) Communication problems*.
 - (5) Make an inquiry to the maker of the Switching equipment.

##1082 [TX/RX] Identified channel does not exist

- Cause:** Indicated above
- Solutions:**
- (1) Re-transmit.
 - (2) Output a communications analysis list, and analyze it.
 - (3) Make sure the 4 digits of the applicable error code are registered in *#4C ISDN BASIC, [G4/G3 Fallback]* and *[Speech Fallback]*.
 - (4) Take countermeasures as outlined in *D-channel connection error in this Chapter, 3.6.6 Maintenance and service, c) Communication problems*.
 - (5) Make an inquiry to the maker of the Switching equipment.

##1083 [TX/RX] A suspended call exists, but this call identity does not

- Cause:** Indicated above
- Solutions:**
- (1) Re-establish communication.
 - (2) Output a communications analysis list, and analyze it.
 - (3) Make sure the 4 digits of the applicable error code are registered in *#4C ISDN BASIC, [G4/G3 Fallback]* and *[Speech Fallback]*.
 - (4) Take countermeasures as outlined in *D-channel connection error in this Chapter, 3.6.6 Maintenance and service, c) Communication problems*.
 - (5) Make an inquiry to the maker of the Switching equipment.

##1084 [TX/RX] Call identity in use

- Cause:** Indicated above
- Solutions:**
- (1) Re-establish communication.
 - (2) Output a communications analysis list, and analyze it.
 - (3) Make sure the 4 digits of the applicable error code are registered in *#4C ISDN BASIC*, *[G4/G3 Fallback]* and *[Speech Fallback]*.
 - (4) Take countermeasures as outlined in *D-channel connection error in this Chapter, 3.6.6 Maintenance and service, c) Communication problems*.
 - (5) Make an inquiry to the maker of the Switching equipment.

##1085 [TX/RX] No call suspended

- Cause:** Indicated above
- Solutions:**
- (1) Re-establish communication.
 - (2) Output a communications analysis list, and analyze it.
 - (3) Make sure the 4 digits of the applicable error code are registered in *#4C ISDN BASIC*, *[G4/G3 Fallback]* and *[Speech Fallback]*.
 - (4) Take countermeasures as outlined in *D-channel connection error in this Chapter, 3.6.6 Maintenance and service, c) Communication problems*.
 - (5) Make an inquiry to the maker of the Switching equipment.

##1086 [TX/RX] Call having the requested call identity has been cleared

- Cause:** Indicated above
- Solutions:**
- (1) Re-establish communication.
 - (2) Output a communications analysis list, and analyze it.
 - (3) Make sure the 4 digits of the applicable error code are registered in *#4C ISDN BASIC*, *[G4/G3 Fallback]* and *[Speech Fallback]*.
 - (4) Take countermeasures as outlined in *D-channel connection error in this Chapter, 3.6.6 Maintenance and service, c) Communication problems*.
 - (5) Make an inquiry to the maker of the Switching equipment.

##1088 [TX/RX] Incompatible destination

- Cause:** Indicated above
- Solutions:**
- (1) Re-check the other party's terminal type, then re-transmit.
 - (2) Output a communications analysis list, and analyze it.
 - (3) Make sure the 4 digits of the applicable error code are registered in *#4C ISDN BASIC*, *[G4/G3 Fallback]* and *[Speech Fallback]*.
 - (4) Take countermeasures as outlined in *D-channel connection error in this Chapter, 3.6.6 Maintenance and service, c) Communication problems*.
 - (5) Make an inquiry to the maker of the Switching equipment.

##1089 [TX/RX] Line busy

Cause: Indicated above**Solutions:**

- (1) Re-transmit.
- (2) Output a communications analysis list, and analyze it.
- (3) Make sure the 4 digits of the applicable error code are registered in *#4C ISDN BASIC, [G4/G3 Fallback]* and *[Speech Fallback]*.
- (4) Take countermeasures as outlined in *D-channel connection error in this Chapter, 3.6.6 Maintenance and service, c) Communication problems.*
- (5) Make an inquiry to the maker of the Switching equipment.

##1090 [TX/RX] Release from the other party number or from a distant exchange

Cause: Indicated above**Solutions:**

- (1) Re-establish communication.
- (2) Output a communications analysis list, and analyze it.
- (3) Make sure the 4 digits of the applicable error code are registered in *#4C ISDN BASIC, [G4/G3 Fallback]* and *[Speech Fallback]*.
- (4) Take countermeasures as outlined in *D-channel connection error in this Chapter, 3.6.6 Maintenance and service, c) Communication problems.*
- (5) Make an inquiry to the maker of the Switching equipment.

##1091 [TX/RX] Invalid transit network selection

Cause: Indicated above**Solutions:**

- (1) Re-check the designated relay network, and re-transmit.
- (2) Output a communications analysis list, and analyze it.
- (3) Make sure the 4 digits of the applicable error code are registered in *#4C ISDN BASIC, [G4/G3 Fallback]* and *[Speech Fallback]*.
- (4) Take countermeasures as outlined in *D-channel connection error in this Chapter, 3.6.6 Maintenance and service, c) Communication problems.*
- (5) Make an inquiry to the maker of the Switching equipment.

##1092 [TX/RX] Disconnection from network

Cause: Indicated above**Solutions:**

- (1) Re-check the phone number and try the call again.
- (2) Output a communications analysis list, and analyze it.
- (3) Make sure the 4 digits of the applicable error code are registered in *#4C ISDN BASIC, [G4/G3 Fallback]* and *[Speech Fallback]*.
- (4) Take countermeasures as outlined in *D-channel connection error in this Chapter, 3.6.6 Maintenance and service, c) Communication problems.*
- (5) Make an inquiry to the maker of the Switching equipment.

##1095 [TX/RX] Invalid message, unspecified

Cause: Indicated above

- Solutions:**
- (1) Re-establish communication.
 - (2) Output a communications analysis list, and analyze it.
 - (3) Make sure the 4 digits of the applicable error code are registered in *#4C ISDN BASIC, [G4/G3 Fallback]* and *[Speech Fallback]*.
 - (4) Take countermeasures as outlined in *D-channel connection error in this Chapter, 3.6.6 Maintenance and service, c) Communication problems.*
 - (5) Make an inquiry to the maker of the Switching equipment.

##1096 [TX/RX] Mandatory information element is missing

Cause: Indicated above

- Solutions:**
- (1) Re-establish communication.
 - (2) Output a communications analysis list, and analyze it.
 - (3) Make sure the 4 digits of the applicable error code are registered in *#4C ISDN BASIC, [G4/G3 Fallback]* and *[Speech Fallback]*.
 - (4) Take countermeasures as outlined in *D-channel connection error in this Chapter, 3.6.6 Maintenance and service, c) Communication problems.*
 - (5) Make an inquiry to the maker of the Switching equipment.

##1097 [TX/RX] Message type non-existent or not implemented

Cause: Indicated above

- Solutions:**
- (1) Re-check the designated service contract, and re-establish communication.
 - (2) Output a communications analysis list, and analyze it.
 - (3) Make sure the 4 digits of the applicable error code are registered in *#4C ISDN BASIC, [G4/G3 Fallback]* and *[Speech Fallback]*.
 - (4) Take countermeasures as outlined in *D-channel connection error in this Chapter, 3.6.6 Maintenance and service, c) Communication problems.*
 - (5) Make an inquiry to the maker of the Switching equipment.

##1098 [TX/RX] Message not compatible with call state or message type non-existent or not

Cause: Indicated above

- Solutions:**
- (1) Re-establish communication.
 - (2) Output a communications analysis list, and analyze it.
 - (3) Make sure the 4 digits of the applicable error code are registered in *#4C ISDN BASIC, [G4/G3 Fallback]* and *[Speech Fallback]*.
 - (4) Take countermeasures as outlined in *D-channel connection error in this Chapter, 3.6.6 Maintenance and service, c) Communication problems.*
 - (5) Make an inquiry to the maker of the Switching equipment.

##1099 [TX/RX] Information element non-existent or not implemented

Cause: Indicated above

- Solutions:**
- (1) Re-establish communication.
 - (2) Output a communications analysis list, and analyze it.
 - (3) Make sure the 4 digits of the applicable error code are registered in *#4C ISDN BASIC, [G4/G3 Fallback]* and *[Speech Fallback]*.
 - (4) Take countermeasures as outlined in *D-channel connection error in this Chapter, 3.6.6 Maintenance and service, c) Communication problems*.
 - (5) Make an inquiry to the maker of the Switching equipment.

##1100 [TX/RX] Invalid information element contents

Cause: Indicated above

- Solutions:**
- (1) Re-establish communication.
 - (2) Output a communications analysis list, and analyze it.
 - (3) Make sure the 4 digits of the applicable error code are registered in *#4C ISDN BASIC, [G4/G3 Fallback]* and *[Speech Fallback]*.
 - (4) Take countermeasures as outlined in *D-channel connection error in this Chapter, 3.6.6 Maintenance and service, c) Communication problems*.
 - (5) Make an inquiry to the maker of the Switching equipment.

##1101 [TX/RX] Message not compatible with call state

Cause: Indicated above

- Solutions:**
- (1) Re-establish communication.
 - (2) Output a communications analysis list, and analyze it.
 - (3) Make sure the 4 digits of the applicable error code are registered in *#4C ISDN BASIC, [G4/G3 Fallback]* and *[Speech Fallback]*.
 - (4) Take countermeasures as outlined in *D-channel connection error in this Chapter, 3.6.6 Maintenance and service, c) Communication problems*.
 - (5) Make an inquiry to the maker of the Switching equipment.

##1102 [TX/RX] Recovery on timer expire

Cause: Indicated above

- Solutions:**
- (1) Re-check the designated relay network, and re-establish communication.
 - (2) Output a communications analysis list, and analyze it.
 - (3) Make sure the 4 digits of the applicable error code are registered in *#4C ISDN BASIC, [G4/G3 Fallback]* and *[Speech Fallback]*.
 - (4) Take countermeasures as outlined in *D-channel connection error in this Chapter, 3.6.6 Maintenance and service, c) Communication problems*.
 - (5) Make an inquiry to the maker of the Switching equipment.

##1103 [TX/RX] Disconnection from network

Cause: Indicated above

- Solutions:**
- (1) Re-check the phone number and try the call again.
 - (2) Output a communications analysis list, and analyze it.
 - (3) Make sure the 4 digits of the applicable error code are registered in *#4C ISDN BASIC, [G4/G3 Fallback]* and *[Speech Fallback]*.
 - (4) Take countermeasures as outlined in *D-channel connection error in this Chapter, 3.6.6 Maintenance and service, c) Communication problems.*
 - (5) Make an inquiry to the maker of the Switching equipment.

##1111 [TX/RX] Protocol error, unspecified

Cause: Indicated above

- Solutions:**
- (1) Re-establish communication.
 - (2) Output a communications analysis list, and analyze it.
 - (3) Make sure the 4 digits of the applicable error code are registered in *#4C ISDN BASIC, [G4/G3 Fallback]* and *[Speech Fallback]*.
 - (4) Take countermeasures as outlined in *D-channel connection error in this Chapter, 3.6.6 Maintenance and service, c) Communication problems.*
 - (5) Make an inquiry to the maker of the Switching equipment.

##1112 [TX/RX] Release because of error in a local area

Cause: Indicated above

- Solutions:**
- (1) Re-establish communication.
 - (2) Output a communications analysis list, and analyze it.
 - (3) Make sure the 4 digits of the applicable error code are registered in *#4C ISDN BASIC, [G4/G3 Fallback]* and *[Speech Fallback]*.
 - (4) Take countermeasures as outlined in *D-channel connection error in this Chapter, 3.6.6 Maintenance and service, c) Communication problems.*
 - (5) Make an inquiry to the maker of the Switching equipment.

**##1113 [TX/RX] a) Release because of error in a distant area
b) Disconnection from network**

-
- Cause a):** Indicated above
- Solutions a):**
- (1) Re-establish communication.
 - (2) Output a communications analysis list, and analyze it.
 - (3) Make sure the 4 digits of the applicable error code are registered in *#4C ISDN BASIC, [G4/G3 Fallback]* and *[Speech Fallback]*.
 - (4) Take countermeasures as outlined in *D-channel connection error in this Chapter, 3.6.6 Maintenance and service, c) Communication problems.*
 - (5) Make an inquiry to the maker of the Switching equipment.
- Cause b):** Indicated above
- Solutions b):**
- (1) Re-establish communication.
 - (2) Output a communications analysis list, and analyze it.
 - (3) Make sure the 4 digits of the applicable error code are registered in *#4C ISDN BASIC, [G4/G3 Fallback]* and *[Speech Fallback]*.
 - (4) Take countermeasures as outlined in *D-channel connection error in this Chapter, 3.6.6 Maintenance and service, c) Communication problems.*
 - (5) Make an inquiry to the maker of the Switching equipment.

##1114 [TX/RX] Disconnection from network

-
- Cause:** Indicated above
- Solutions:**
- (1) Re-check the phone number and try the call again.
 - (2) Output a communications analysis list, and analyze it.
 - (3) Make sure the 4 digits of the applicable error code are registered in *#4C ISDN BASIC, [G4/G3 Fallback]* and *[Speech Fallback]*.
 - (4) Take countermeasures as outlined in *D-channel connection error in this Chapter, 3.6.6 Maintenance and service, c) Communication problems.*
 - (5) Make an inquiry to the maker of the Switching equipment.

##1126 [TX/RX] Disconnection from network

-
- Cause:** Indicated above
- Solutions:**
- (1) Re-check the phone number and try the call again.
 - (2) Output a communications analysis list, and analyze it.
 - (3) Make sure the 4 digits of the applicable error code are registered in *#4C ISDN BASIC, [G4/G3 Fallback]* and *[Speech Fallback]*.
 - (4) Take countermeasures as outlined in *D-channel connection error in this Chapter, 3.6.6 Maintenance and service, c) Communication problems.*
 - (5) Make an inquiry to the maker of the Switching equipment.

##1127 [TX/RX] Interworking, unspecified

- Cause:** Indicated above
- Solutions:**
- (1) Re-establish communication.
 - (2) Output a communications analysis list, and analyze it.
 - (3) Make sure the 4 digits of the applicable error code are registered in *#4C ISDN BASIC, [G4/G3 Fallback]* and *[Speech Fallback]*.
 - (4) Take countermeasures as outlined in *D-channel connection error in this Chapter, 3.6.6 Maintenance and service, c) Communication problems.*
 - (5) Make an inquiry to the maker of the Switching equipment.

##1130 [TX/RX] D-channel abnormal

- Cause:** Unrecoverable error occurred in D-channel layer 2,3 protocol procedure
- Solutions:**
- (1) Make sure the line correctly connected.
 - (2) Switch the power OFF/ON, then re-transmit.
 - (3) Output a communications analysis list, and analyze it.
 - (4) Make sure the 4 digits of the applicable error code are registered in *#4C ISDN BASIC, [G4/G3 Fallback]* and *[Speech Fallback]*.
 - (5) Take countermeasures as outlined in *D-channel connection error in this Chapter, 3.6.6 Maintenance and service, c) Communication problems.*
 - (6) Make an inquiry to the maker of the Switching equipment.

##1131 [TX/RX] D-channel connection monitoring timer timed out

- Cause:** When calling, the connection (disconnection) from the other party expired in a fixed time interval with no response.
- Solutions:**
- (1) Check to see if the other party is absent or whether they are receiving manually.
 - (2) Output a communications analysis list, and analyze it.
 - (3) Make sure the 4 digits of the applicable error code are registered in *#4C ISDN BASIC, [G4/G3 Fallback]* and *[Speech Fallback]*.
 - (4) Take countermeasures as outlined in *D-channel connection error in this Chapter, 3.6.6 Maintenance and service, c) Communication problems.*
 - (5) Make an inquiry to the maker of the Switching equipment.

• B-channel error codes

##1255 [RX] B-channel was disconnected without the document being started

- Cause:** After the negotiation procedure on the transmitting side, a disconnection occurred without the document being transmitted.
- Solutions:**
- (1) Have the transmitted party set the document properly
 - (2) Output a communications analysis list, and analyze it.

##1309 [TX/RX] Abnormal post-reception checkpoint reference number (page number)

- Cause:** The page is completed, and the checkpoint reference number which is the parameter used during CDE, CDPB, RDEP or RDPBP is abnormal (a series of long, non-numeric parameters, etc.)
- Solutions:**
- (1) Re-establish communication.
 - (2) Output a communications analysis list, and analyze it.

##1321 [TX/RX] 1-page transmission time-out

- Cause:** Indicated above
- Solutions:**
- (1) Lower the document's transmission resolution, then re-establish communication.
 - (2) Output a communications analysis list, and analyze it

##1322 [RX] Other machine's terminal properties abnormal (session procedures)

- Cause:** As a result of negotiation, the attributes of the terminal which show session user data are abnormal (abnormality in a non-G4 facsimile parameter, etc.)
- Solutions:**
- (1) Re-establish communication.
 - (2) Output a communications analysis list, and analyze it.

##1323 [TX] RSSN reception

- Cause:** Compared with CSS transmission, the receiving side transmitted RSSN
- Solutions:**
- (1) Re-transmit
 - (2) Output a communications analysis list, and analyze it.

##1332 [TX/RX] Other terminal's properties are abnormal (Document procedures)

- Cause:** As a result of negotiation, the attributes of the terminal which show session user data are abnormal (abnormality in a non-G4 facsimile parameter, etc.)
- Solutions:**
- (1) Re-establish communication.
 - (2) Output a communications analysis list, and analyze it.

##1334 [RX] Document attributes abnormal

Cause: Attributes of the received page such as size, resolution, and encoding method are abnormal.

- Solutions:**
- (1) Re-establish communication.
 - (2) Output a communications analysis list, and analyze it.

##1336 [TX/RX] CSA reception

Cause: CSA was received from the other machine during transmission

- Solutions:**
- (1) Check whether the receiving machine's memory is full when transmitting.
 - (2) Check whether the other machine's communication process has been stopped.
 - (3) Re-establish communication.
 - (4) Output a communications analysis list, and analyze it.

##1337 [RX] Non-transmission monitoring timer (T.62 T1 timer) timed out

Cause: Expired in a fixed interval without receiving the data frame from the sending side without the document being transmitted.

- Solutions:**
- (1) Check whether the other party's machine is working properly.
 - (2) Re-establish communication.
 - (3) Output a communications analysis list, and analyze it.

##1339 [RX] CDR reception

Cause: CDR received from the transmitting side with document procedures

- Solutions:**
- (1) Check whether the other party's machine is working properly.
 - (2) Re-establish communication.
 - (3) Output a communications analysis list, and analyze it.

##1340 [RX] CDD reception

Cause: CDD received from the transmitting side with document procedures

- Solutions:**
- (1) Check whether the other party's machine is working properly.
 - (2) Re-establish communication.
 - (3) Output a communications analysis list, and analyze it.

##1341 [TX] RDPBN reception

Cause: RDPBN received from the transmitting side with document procedures

The page could not be received correctly by the receiving side.

- Solutions:**
- (1) Re-transmit from the page where the error occurred.
 - (2) Output a communications analysis list, and analyze it.

##1348 [TX/RX] Session layer abnormal (Document procedure)

- Cause:** Underfined document procedure frame received with document properties
- Solutions:**
- (1) Re-establish communication.
 - (2) Output a communications analysis list, and analyze it.

##1350 [RX] CSS parameter abnormal

- Cause:** Session procedures received, abnormality discovered in CSS contents
- Solutions:**
- (1) Re-establish communication.
 - (2) Output a communications analysis list, and analyze it.

##1351 [TX] RSSP (RSSN) parameter abnormal

- Cause:** Session procedures received, abnormality discovered in RSSP or RSSN contents
- Solutions:**
- (1) Re-transmit.
 - (2) Output a communications analysis list, and analyze it..

##1352 [RX] CSE parameter abnormal

- Cause:** Session procedures received, abnormality discovered in CSE contents
- Solutions:**
- (1) Re-establish communication.
 - (2) Output a communications analysis list, and analyze it.

##1353 [TX] RSEP parameter abnormal

- Cause:** Session procedures received, abnormality discovered in RSEP contents
- Solutions:**
- (1) Re-transmit.
 - (2) Output a communications analysis list, and analyze it.

##1354 [RX] CSCC parameter abnormal

- Cause:** Session procedures received, abnormality discovered in CSCC contents
- Solutions:**
- (1) Re-establish communication.
 - (2) Output a communications analysis list, and analyze it.

##1355 [TX] RSCCP parameter abnormal

- Cause:** Session procedures received, abnormality discovered in RSCCP contents
- Solutions:**
- (1) Re-transmit.
 - (2) Output a communications analysis list, and analyze it.

##1372 [RX] CDS parameter abnormal

Cause: Document procedures received, abnormality discovered in CDS contents

- Solutions:**
- (1) Have the document set properly on the transmitting side.
 - (2) Output a communications analysis list, and analyze it.

##1373 [RX] CDC parameter abnormal

Cause: Document procedures received, abnormality discovered in CDC contents

- Solutions:**
- (1) Re-establish communication.
 - (2) Output a communications analysis list, and analyze it.

##1380 [RX] CDE parameter abnormal

Cause: Document procedures received, abnormality discovered in CDE contents

- Solutions:**
- (1) Re-establish communication.
 - (2) Output a communications analysis list, and analyze it.

##1381 [TX] RDEP parameter abnormal

Cause: Document procedures received, abnormality discovered in RDEP contents

- Solutions:**
- (1) Re-transmit.
 - (2) Output a communications analysis list, and analyze it.

##1386 [RX] CDPB parameter abnormal

Cause: Document procedures received, abnormality discovered in CDPB contents

- Solutions:**
- (1) Re-establish communication.
 - (2) Output a communications analysis list, and analyze it.

##1387 [TX] RDPBP parameter abnormal

Cause: Document procedures received, abnormality discovered in RDPBP contents

- Solutions:**
- (1) Re-transmit.
 - (2) Output a communications analysis list, and analyze it.

##1388 [RX] CDCL parameter abnormal

Cause: Document procedures received, abnormality discovered in CDCL contents

- Solutions:**
- (1) Check whether the other party's machine is working properly.
 - (2) Re-establish communication.
 - (3) Output a communications analysis list, and analyze it.

##1389 [TX] RDCLP parameter abnormal

- Cause:** Document procedures received, abnormality discovered in RDCLP contents
- Solutions:**
- (1) Check whether the transmitting machine has been stopped
 - (2) Re-transmit.
 - (3) Output a communications analysis list, and analyze it.

##1412 [TX] RDGR transmission

- Cause:** RDGR received during document procedures
- Solutions:**
- (1) Re-transmit.
 - (2) Output a communications analysis list, and analyze it.

##1413 [TX/RX] Abnormality discovered before session connection

- Cause:** Abnormality discovered in the procedures before session connection (below B-channel layer 4)
- Solutions:**
- (1) Re-establish communication.
 - (2) Output a communications analysis list, and analyze it.

##1414 [TX/RX] Abnormality discovered in the session procedures after session connection

- Cause:** A frame which could not continue session procedures normally, or an undefined frame was received after session connection
- Solutions:**
- (1) Re-establish communication.
 - (2) Output a communications analysis list, and analyze it.

##1417 [TX] Monitoring timer time-out with no response (T.62 T2 timer)

- Cause:** Timed out without getting a response (layer 5 frame reception) from the receiving side during transmission
- Solutions:**
- (1) Confirm that the receiving machine is operating normally
 - (2) Re-transmit.
 - (3) Output a communications analysis list, and analyze it.

##1418 [TX/RX] CSA timer (T.62 T3 timer) time-out

- Cause:** CSA received, or timed-out with no RSAP response
- Solutions:**
- (1) Confirm that the other party's machine is operating normally
 - (2) Re-establish communication.
 - (3) Output a communications analysis list, and analyze it.

##1420 [TX/RX] Session layer protocol violation

- Cause:** Negotiation made with a session windows size larger than 2 (Run the machine only with the session windows size set at 1)
- Solutions:**
- (1) Re-establish communication.
 - (2) Output a communications analysis list, and analyze it.
 - (3) Have the other party change the session windows size on their machine

##1600 [RX] Transmission error in layer 4 or below of B-channel

- Cause:** Session procedures received, abnormality discovered in RSEP contents
- Solutions:**
- (1) Re-transmit.
 - (2) Output a communications analysis list, and analyze it.

##1601 [TX/RX] Connection parameter abnormality in layer 4 connection (transport length)

- Cause:** Indicated above
- Solutions:**
- (1) Re-establish communication.
 - (2) Output a communications analysis list, and analyze it.

##1603 [TX] Abnormal session control function parameter

- Cause:** An abnormality occurred in the session control function parameter which indicates the transmission authority reversal.
- Solutions:**
- (1) Re-transmit.
 - (2) Output a communications analysis list, and analyze it.

##1608 [RX] P-START abnormality

- Cause:** An abnormality occurred during P-START analysis.
- Solutions:**
- (1) Re-establish communication.
 - (2) Output a communications analysis list, and analyze it.

##1618 [RX] Error in presentation layer (layer 6)

- Cause:** Error (Image end terminal detection, MMR error) in presentation layer
- Solutions:**
- (1) Re-establish communication.
 - (2) Output a communications analysis list, and analyze it.

##1620 [RX] D-channel → B-channel connection timer timed-out

- Cause:** Time-out when receiving with no B-channel connection, even though D-channel was connected
- Solutions:**
- (1) Check whether the other party's machine is working properly.
 - (2) Output a communications analysis list, and analyze it.

c) Communication problems

• **D-channel connection error (Service error code “##1001~##1131”)**

- (1) Set #4B ISDN BASIC Bitswitch SW03 bit2 to “1”.
- (2) Set #4B ISDN BASIC Bitswitch SW03 bit4 to “1”.
- (3) Set #4B ISDN BASIC Bitswitch SW03 bit5 to “0”.
- (4) Set #4B ISDN BASIC Bitswitch SW08 bit2 to “0”.
- (5) Set #4B ISDN BASIC Bitswitch SW01 bit4 to “1” and #4B ISDN BASIC Numeric No.19 to “3”.
- (6) Set #4B ISDN BASIC Bitswitch SW06 bit0 to “1”.

• **Cannot perform G4 communication (After a G4 call, fall back to G3. G3 communication will complete normally.)**

- (1) Confirm whether or not the receiving side is using G4FAX.
- (2) Set #4B ISDN BASIC Bitswitch SW03 bit2 to “1”.
- (3) Set #4B ISDN BASIC Bitswitch SW03 bit4 to “1”.

• **Cannot perform communication**

- (1) Check that the ISDN cable is securely connected.
- (2) Check that the kit is securely connected.
- (3) Replace the kit.
- (4) Replace the TWINS board.
- (5) Replace the SCNT board.

d) Signal discription

ISDN G4 board (J1) ↔ TWINS board (J39)

J1	J39	Signal name	Description
A1 ←	A20	nSTROBE	Strobe signal
A2 —	A19	PD0	Data signal
A3 —	A18	PD1	Data signal
A4 —	A17	PD2	Data signal
A5 —	A16	PD3	Data signal
A6 —	A15	PD4	Data signal
A7 —	A14	PD5	Data signal
A8 —	A13	PD6	Data signal
A9 —	A12	PD7	Data signal
A10 →	A11	nACK	ACK signal
A11 →	A10	BUSY	Busy signal
A12 →	A9	PERROR	Print error signal
A13 →	A8	SELECT	Select signal
A14 ←	A7	RESET	Reset signal
A15 →	A6	OPTION0	Option board detection signal 0
A16 →	A5	OPTION1	Option board detection signal 1
A17 →	A4	OPTION2	Option board detection signal 2
A18 —	A3	GND	Ground
A19 ←	A2	SPKON	Speaker on signal
A20 —	A1	N.C	Not connected
B1 —	B20	N.C	Not connected
B2 →	B19	CICNT	CICNT signal
B3 ←	B18	N.C	Not connected
B4 →	B17	N.C	Not connected
B5 →	B16	PSPOUT	Speaker signal
B6 —	B15	GND	Ground
B7 →	B14	N.C	Not connected
B8 →	B13	N.C	Not connected
B9 —	B12	N.C	Not connected
B10 —	B11	N.C	Not connected
B11 —	B10	N.C	Not connected
B12 —	B9	N.C	Not connected
B13 —	B8	GND	Ground
B14 —	B7	GND	Ground
B15 —	B6	GND	Ground
B16 —	B5	GND	Ground
B17 ←	B4	nSELECTIN	Select in signal
B18 ←	B3	nINIT	Initialize signal
B19 →	B2	nFAULT	Fault signal
B20 ←	B1	nAUTOFD	Auto feed signal

ISDN G4 board(J2) ↔ TWINS board (J37)

J2		J37	Signal name	Description
1	—	14	GND	Ground
2	←	13	+12V	Logic drive voltage
3	—	12	GND	Ground
4	—	11	GND	Ground
5	←	10	+3.3V	Logic drive voltage
6	←	9	+3.3V	Logic drive voltage
7	—	8	GND	Ground
8	←	7	+3.3V	Logic drive voltage
9	—	6	GND	Ground
10	—	5	GND	Ground
11	←	4	+5V	Logic drive voltage
12	←	3	+5V	Logic drive voltage
13	←	2	+5V	Logic drive voltage
14	—	1	GND	Ground

ISDN G4 board(J3) ↔ TWINS board (J43)

J3		J43	Signal name	Description
1	—	8	GND	Ground
2	←	7	+12V	Logic drive voltage
5	—	4	GND	Ground
6	←	3	+24V	FAX-L1000 ISDN Kit drive voltage
7	—	2	N.C	Not connected
8	—	5	N.C	Not connected

ISDN G4 board(J3) ↔ G4 Relay board (J2)

J3		J2	Signal name	Description
3	—	2	GND	ground
4	←	1	-12V	Logic drive voltage

G4 Relay board (J1) ↔ TWINS board (J43)

J1		J43	Signal name	Description
1	←	1	+5V	Logic drive voltage
2	—	6	GND	ground

ISDN G4 board(J7) ↔ Mojure board (J203)

J7		J203	Signal name	Description
1	←	1	-RX	ISDN Reception signal
2	←	2	+RX	ISDN Reception signal
3	→	3	-TX	ISDN Transmission signal
4	→	4	+TX	ISDN Transmission signal

3.7 FAX-L1000 Network Printer Upgrade kit

3.7.1 Safety and precautions

Danger by Static Charge

Static charge can change the electrical characteristics of the ethernet board or damage it. Do not handle the ethernet board under circumstances where static charge might occur easily.



When repairing or replacing the ethernet boards, first touch the grounded metal part to prevent damage from static charge, and do not touch electrical parts on the ethernet board.

3.7.2 Service operations

a) External view

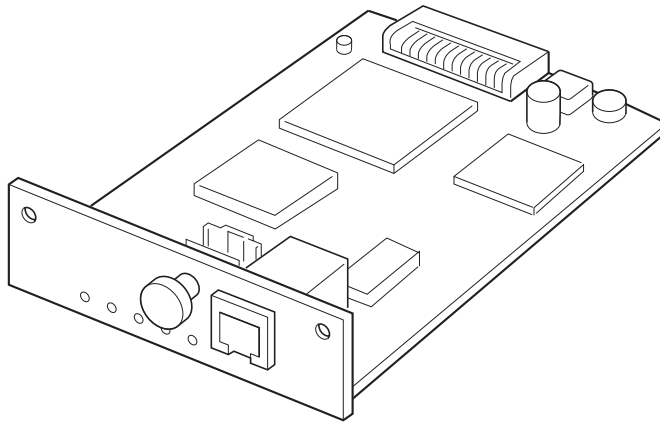

Figure 5-79 External View

3.7.3 Technical information

a) Specification

Interface	10Base-T Ethernet, 100Base-TX Ethernet
CPU	TOSHIBA TMPR3904AF
LAN controller	TOSHIBA TC35815AF
Transceiver	TDK TSC78Q2120
Flash ROM	2MB
DRAM	2MB × 2
Dimensions	139.5(W) × 93.0(D) × 24.7(H)mm (excluding mounting materials and connector.)
Weight	About 0.1kg
Power supply	DC5V (supplied from the printer)
Protocol	IPX/SPX, TCP/IP, AppleTalk, NetBIOS
Frame Type	IPX/SPX:802.2, 802.3, Ethernet II, 802.2 SNAP, AUTO SENSE TCP/IP:Ethernet II AppleTalk:802.2 SNAP(Phase II) NetBIOS:802.2
Print application	IPX/SPX:NDS PServer, Bindery PServer, NPrinter, RPrinter TCP/IP:LPD/UPP AppleTalk:APS NetBIOS:MPS

b) Operations

It is necessary to connect a FAX-L1000 Printer Kit to this board in order to use it. If the board is connected, the main unit can be used as a network printer.

Characteristics of this board are as follows.

- Automatic switching interface for 10Base-T Ethernet and 100Base-TX Ethernet.
- Automatic switching and printing with the following protocols: IPX/SPX(Netware), TCP/IP, AppleTalk, NetBEUI(NetBOIS).
- Device configurations and management are supported over Telnet and NetSpot, a graphical user interface and SNMP-based printer management utility shipped with the product which supports Windows98, 95, WindowsNT, Solaris 2.X, and Macintosh platforms.
- Can generate a Test Print which lists the current protocol configuration of the ethernet board and send it to the connected printer.
- Firmware of the ethernet board is upgradable with NetSpot.

c) Status LEDs

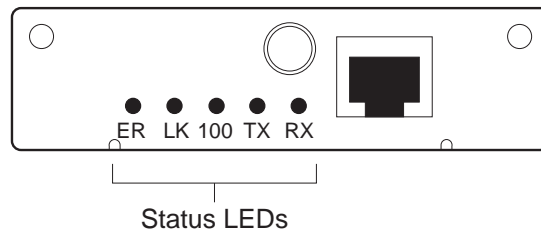

Figure 5-80 Status LEDs

•**ER (Error) LED**

When the ethernet board is operating normally:

ER may flash several times during initialization, then go off.

When the ethernet board is not operating normally:

ER lights or flashes all the time.

•**LK (Link) LED**

Lights yellow while the ethernet board is connected to the network and functioning normally.

•**100 (100Mbps) LED**

Lights yellow while the ethernet board is connected to the network via a 100Base-TX.

•**TX (Transmit) LED**

Lights yellow while data is being sent from the ethernet board.

•**RX (Receive) LED**

Lights yellow when the ethernet board is receiving data.

3.7.4 Maintenance and Service

a) Troubleshooting

Every time the main unit is switched ON, the ethernet board automatically performs a self-diagnostic test. If the self-diagnostic test detects no errors, the LK LED lights and stays on. After the main unit is switched ON, the ER LED starts flashing and continues flashing until the ethernet board is ready to operate. If the ER LED lights orange and remains on, or if it continues to flash, follow the procedures below.

ER LED lights or flashes once, twice, or three times in sequence.

<Possible causes>

1. The ethernet board is defective.

Action: Replace the ethernet board.

ER LED flashes four times in sequence.

<Possible causes>

1. The ethernet cable connection is loose or broken, or the ethernet board is not installed correctly.

Action: Check the connectors on both ends of the cable connecting the ethernet board to the ethernet. Make sure the RJ45 connectors are undamaged and securely fastened at both connection points.

2. Peerless standard I/O interface connector are loose.

Action: Reinstall the ethernet board.

3. The ethernet board is defective.

Action: Replace the ethernet board.

"ETHERNET OPTION ERROR"

<Possible causes>

1. Defective optional ethernet board

Action: Replace the ethernet board.

2. Defective PDL board

Action: Replace the PDL board.

b) Connector locations

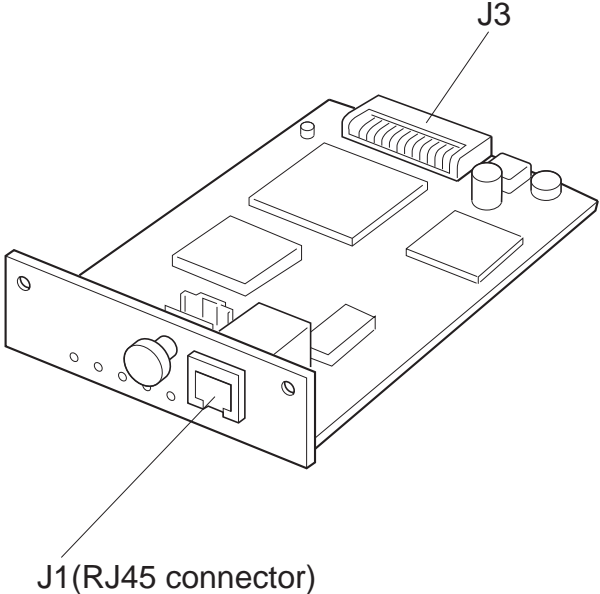

Figure 5-81 Connector Locations

c) Signal description

Ethernet board(J1) ↔ Network

J1		Network	Signal name	Description
1	→	Network	TX+	Send Data Line(+)
2	→	Network	TX-	Send Data Line(-)
3	←	Network	RX+	Receive Data Line(+)
4	—	Network	N.C.	Not used
5	—	Network	N.C.	Not used
6	←	Network	RX-	Receive Data Line(-)
7	—	Network	N.C.	Not used
8	—	Network	N.C.	Not used

Ethernet board(J3) ↔ Adapter board connector(J2)

J3		J2	Signal name	Description
A1	—	A1	+5V	Logic drive voltage
A2	→	A2	nINTR	Interrupt request
A3	←	A3	nRESET	Reset
A4	←	A4	nIOWR	I/O Write
A5	←	A5	nIOCS	I/O Chip select
A6	—	A6	(Reserved)	
A7	—	A7	GND	Ground
A8	—	A8	D00	Data bit 0
A9	—	A9	D02	Data bit 2
A10	—	A10	D04	Data bit 4
A11	—	A11	D06	Data bit 6
A12	—	A12	D08	Data bit 8
A13	—	A13	D10	Data bit 10
A14	—	A14	D12	Data bit 10
A15	—	A15	D14	Data bit 10
A16	—	A16	GND	Ground
A17	←	A17	A02	Address bit2
A18	←	A18	A04	Address bit4
A19	←	A19	A06	Address bit6
A20	←	A20	A08	Address bit8
A21	←	A21	A10	Address bit10
A22	←	A22	A12	Address bit12
A23	←	A23	A14	Address bit14
A24	←	A24	A16	Address bit16
A25	←	A25	+5V	Logic drive voltage
B1	—	B1	GND	Ground
B2	→	B2	nWAIT	Wait
B3	←	B3	nWnR	Write/Read
B4	←	B4	nIORD	I/O Read enable
B5	←	B5	A23	Address bit23

Ethernet board(J3) ↔ Adapter board connector(J2)

J3		J2	Signal name	Description
B6	—	B6	(Reserved)	
B7	—	B7	GND	Ground
B8	—	B8	D01	Data bit 1
B9	—	B9	D03	Data bit 3
B10	—	B10	D05	Data bit 5
B11	—	B11	D07	Data bit 7
B12	—	B12	D09	Data bit 9
B13	—	B13	D11	Data bit 11
B14	—	B14	D13	Data bit 13
B15	—	B15	D15	Data bit 15
B16	—	B16	GND	Ground
B17	←	B17	A03	Address bit 3
B18	←	B18	A05	Address bit 5
B19	←	B19	A07	Address bit 7
B20	←	B20	A09	Address bit 8
B21	←	B21	A11	Address bit 11
B22	←	B22	A13	Address bit 13
B23	←	B23	A15	Address bit 15
B24	←	B24	A17	Address bit 17
B25	—	B25	GND	Ground

3.8 FAX-L1000 PostScript kit

3.8.1 Safety and precautions

Danger by Static Charge

Static charge can change the electrical characteristics of the DIMM or damage it. Do not handle the DIMM under circumstances where static charge might occur easily.



When repairing or replacing the DIMMs, first touch the grounded metal part to prevent damage from static charge, and do not touch electrical parts on the DIMM.

3.8.2 Service operations

a) External view

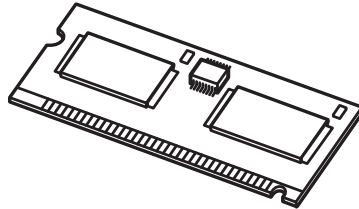
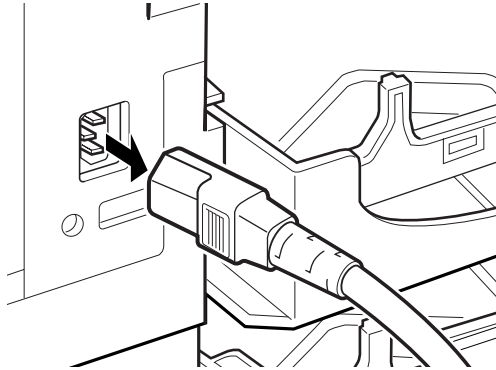



Figure 5-82 External View

b) Installation

- b-1) Unplug the power cord and remove any interface cables from the rear of the printer.



- b-2) Remove the telephone line from the fax jack marked  .
- b-3) Remove end of the handset connector cord from the extension phone jack marked  and remove the handset from the handset cradle.
- b-4) Remove the screw in the side cover.

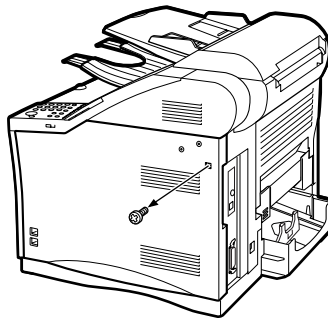

- b-5) Remove the side cover by sliding it sideways until it unlocks from the printer.

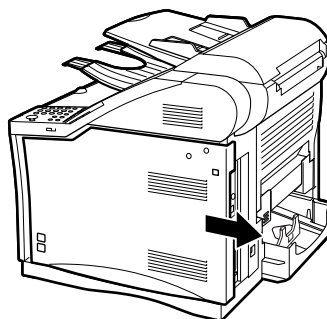

- b-6) Flip the top of the side cover outwards, then lift the cover slightly and remove it from the printer.

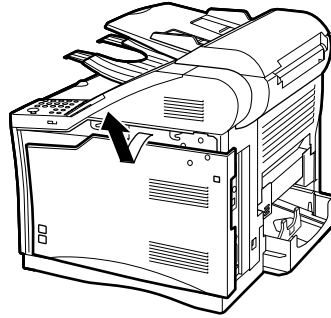

- b-7) Loosen the screw at the top of the memory slot cover.

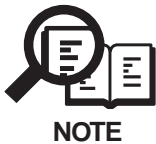
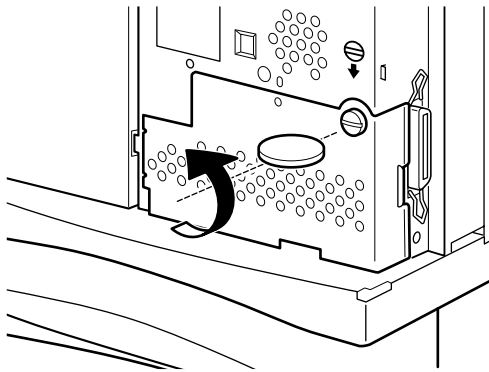

NOTE

Loosen the screw with a large coin, or similar object, then use your fingers to rotate the screw until the cover opens. You do not need to remove the screw completely.

- b-8) Swing open the cover and lift it off the printer.

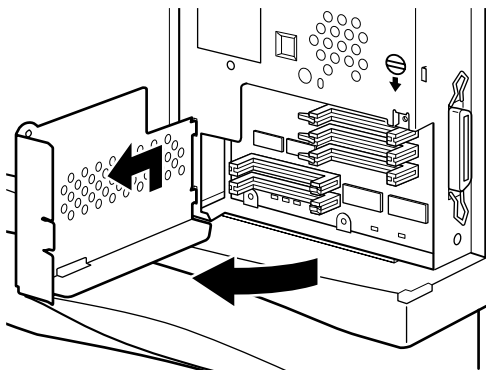

To avoid electric shock, do not open the covers.

- b-9) Remove the ROM DIMM from its packaging and insert it into the socket by pushing it into the middle of the three slots at the top right of the motherboard until it snaps into place.

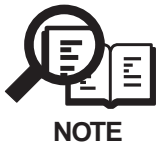
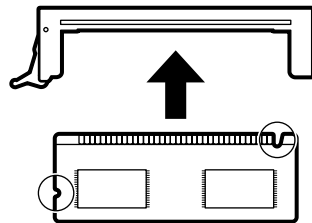
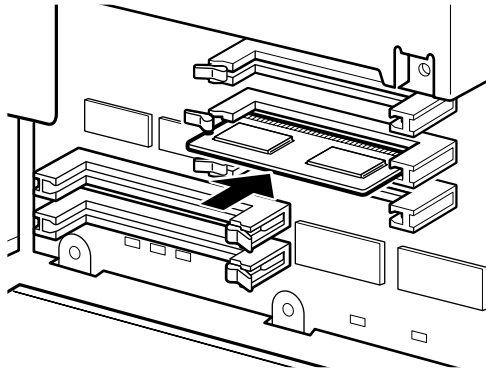

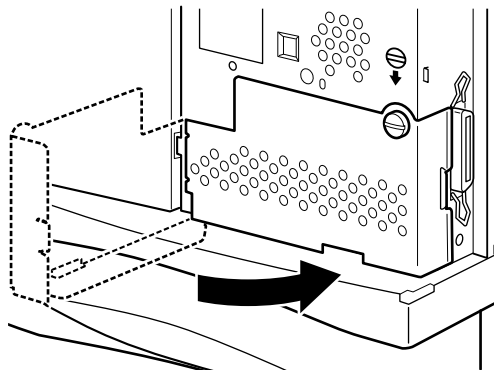

- Be sure to open the entrance to the second socket by pushing back on the left tab for that slot.
- Make sure the indent on the module is on the right side of the module as you press it into the board.
- If the module is inserted into a different slot, it will not operate correctly. Therefore, be sure to insert the module into the correct (middle) slot.

- b-10) Place the memory slot cover back on the printer and close it.

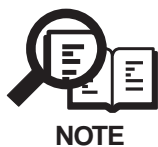
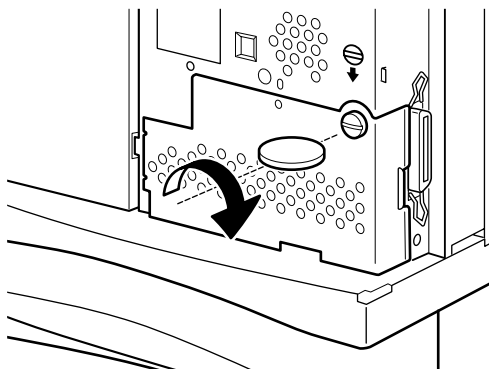

- b-11) Tighten the screw at the top of the memory slot cover to secure it in position.



- Replace the side cover after you have finished adding the DIMM boards.
- Plug in the power cord and any interface cables you removed from the rear of the printer.
- Reconnect the telephone line to the fax jack marked .
- Reconnect the end of the handset connector cord to the extension phone jack marked  and place the handset on the handset cradle.

- b-12) Performing a Cold Reset. Please refer to 3.10.2 *Service Operations: c) Cold Rest* when performing a Cold Reset.

3.8.3 Technical Information

a) Specifications

Type	ROM DIMM, 72-pin
Capacity	8MB
Font	136fonts
PDL	Adobe PostScript Level 3

b) Operations

This DIMM contains 136 types of PS fonts and a program to interpret PostScript Level 3 (PS). By connecting this DIMM to the main unit, the main unit can be used as a PS printer other than PCL.

The PDL unit distinguishes between PCL and PS.

3.8.4 Maintenance and service

a) Troubleshooting

"PS OPTION ERROR"

<Possible causes>

1. Defective optional PS ROM DIMM
Action: Replace the PS ROM DIMM.

2. Defective PDL board
Action: Replace the PDL board.

3.9 RAM DIMM Module

3.9.1 Safety and precautions

Danger by Static Charge

Static charge can change the electrical characteristics of the DIMM or damage it. Do not handle the DIMM under circumstances where static charge might occur easily.



When repairing or replacing the DIMMs, first touch the grounded metal part to prevent damage from static charge, and do not touch electrical parts on the DIMM.

3.9.2 Service operations

a) External View

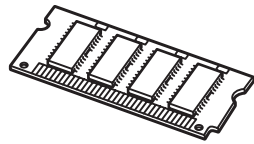

16MB

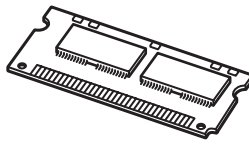

8MB

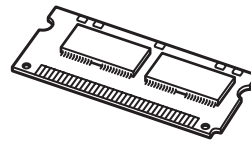

4MB

Figure 5-83 External View

b) Installation

Please refer to FAX-L1000 PostScript Kit step b-8) for the procedures up to opening the side cover.

- b-1) Open the tab on the right side of the memory slot by moving it to the right.
- b-2) Remove the RAM DIMM from its packaging and insert it into the socket at the bottom of the memory slot board.

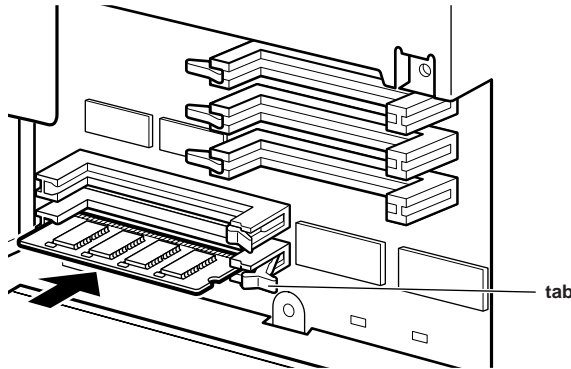

- b-3) Make sure: the tab of the memory slot snaps close.

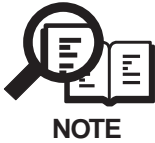

Make sure the notch on the front edge of the RAM DIMM is to the left when you insert the RAM DIMM into the socket.

- b-4) Insert the other RAM DIMM into the second slot above the first DIMM following the procedure above.

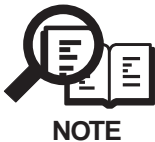
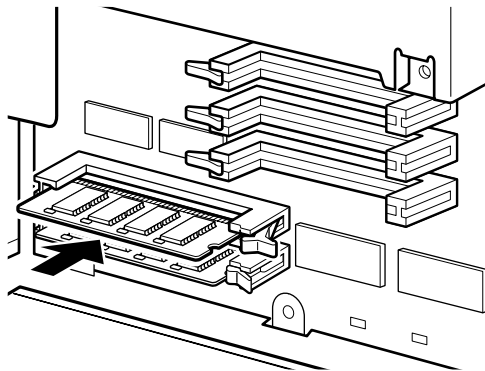

There are 4MB, 8MB, and 16MB RAM DIMMs available.

- b-5) Perform the Cold Reset. Please refer to 3.10.2 Service Operations: c) Cold Rest when performing the Cold Reset.

3.9.3 Technical informations

a) Specifications

Type	EDO RAM DIMM, 72-Pin
Access time	60ns
Capacity	4MB, 8MB, 16MB

b) Operations

This option memory is used to store print data, and it comes in several sizes:4MB, 8MB, and 16MB.

The printer uses an advanced Memory Reduction Technology that compresses documents, when necessary. This reduces the memory requirements for printing complex pages. These could include duplex documents, documents using a variety of fonts, scanned or dithered photographs and documents containing large amounts of graphical data. This type of compression greatly reduces memory errors while printing, however, it can also reduce the print speed and print quality of some documents. With more memory, the printer can handle more complex documents without having to use compression.

The table below lists the minimum amount of total memory required for duplex printing to operate effectively. For example, the printer has 4 MB of standard memory so for the 8 MB listed in the table below, you need an additional 4 MB of memory.

Minimum Memory Requirements for the Duplex Unit

Print resolution	Page Size	No duplex unit installed	Duplex unit installed
300 x 300 dpi	Letter, A4	4 MB	4 MB
	Legal	4 MB	4 MB
600 x 600 dpi	Letter, A4	4 MB	4 MB
	Legal	4 MB	8 MB
1200 x 1200 dpi	Letter, A4	4 MB	8 MB
	Legal	8 MB	12 MB



NOTE

Canon recommends adding more memory than listed above.

Even with a total of 8 MB, you may need to install additional memory if you frequently print complicated documents that contain large amounts of data.

3.9.4 Maintenance and service

a) Troubleshooting

The main unit does not recognize the optional memory

<Possible causes>

1. Defective optional memory

Action: Replace the optional memory

2. Defective PDL board

Action: Replace PDL board

"OPTION RAM ERROR"

<Possible causes>

1. Defective optional RAM DIMM

Action: Replace the RAM DIMM.

2. Defective PDL board

Action: Replace the PDL board.

3.10 FAX-L1000 Printer kit

3.10.1 Safety and precautions

When attaching this unit to the main unit, take care not to touch the hands with the power supply elements (heat sink, etc.). If the hands touch the elements, burns may result.

3.10.2 Service operations

a) Eternal View

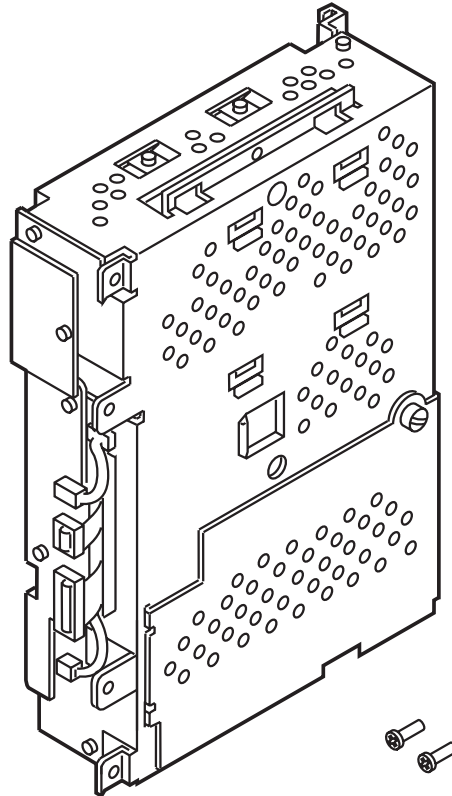

Figure 5-84 External View

b) Installation

b-1) Unpacking

Check that the box contains the FAX-L1000 Printer kit and the two screws.

b-2) Preparation

Perform the operations below before attaching the option.

- (1) Disconnect the modular jack cord (telephone line) from the fax.
- (2) Disconnect the power cord of the fax unit at the power source. Wait at least 10 minutes for the power supply unit to cool before continuing to work.
- (3) Remove the one screw and remove the right cover.

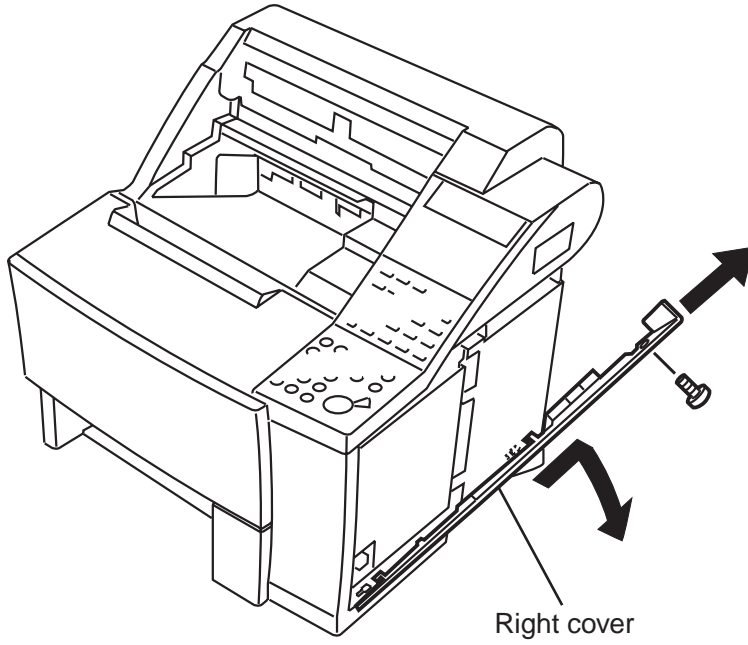

Figure 5-85 Preparations for Installation 1

(4) Remove the six screws and remove the shield cover.

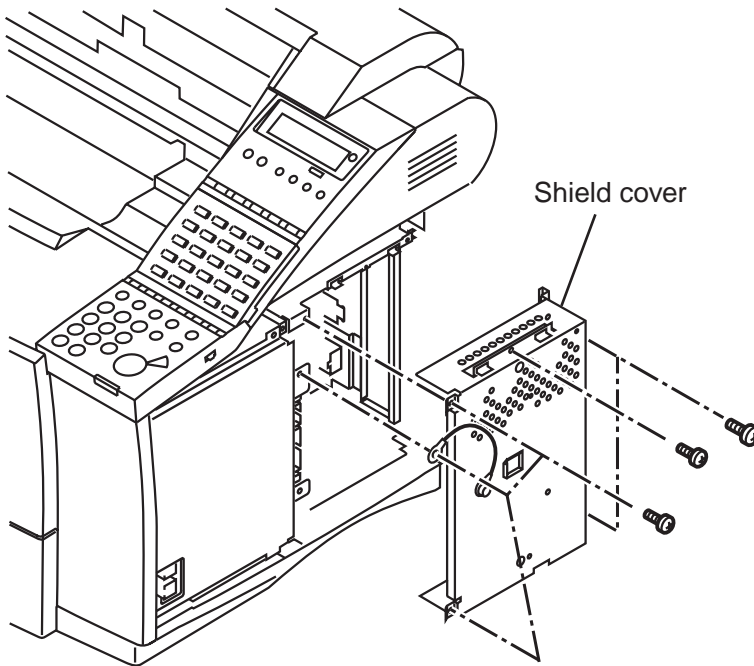

Figure 5-86 Preparations for Installation 2

b-3) Attaching the option

- (1) Insert the option into the main unit. Attach the option by aligning it with the hooks in the circles in the figure and sliding it in the figure indicated by the black arrow.
- (2) After inserting the option, insert connectors of the option into J33, J34, J35 and J40 on the TWINS board.
- (3) Fasten the option in place with the seven screws.

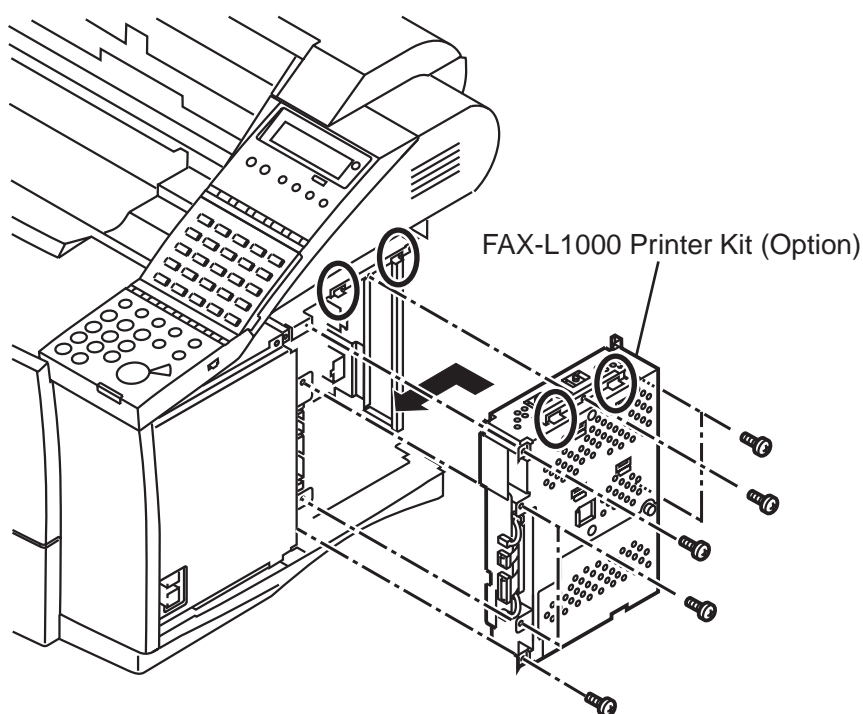

Figure 5-87 FAX-L1000 Printer Kit Installation

- (4) Fasten the right cover in place with the one screw.

b-4) Performing a Cold Reset

Please refer to *item c)* when performing a Cold Reset.

b-5) Removing the option

When removing the option, perform the steps in *b-3) Attaching the option* in reverse order. Be sure to remove the option only after turning the power off.

c) Cold Reset

The term “Cold Reset” is used to indicate the function by which the settings stored in the NVRAM on the PDL board are reset to factory default settings. If you have installed an optional module or card for the PDL board, you must execute this function.

User data and service data are not changed even if Cold Reset is done.

Cold Reset may be any of the following three types:

•**Cold Reset**

Used to reset all settings except the recording paper size under PAGE COUNT and TEST PRINT of TEST MENU back to their factory default settings.

•**Cold Reset A4**

Used to set the recording paper size under TEST PRINT to A4 and to reset all other settings to factory default settings. The PAGE COUNT data will be cleared.

•**Cold Reset LTR**

Used to set the recording paper size under TEST PRINT to LTR and to reset all other settings to factory default settings. The PAGE COUNT data will be cleared.

If you have installed a PDL board, be sure to use Cold Reset A4 or Cold Reset LTR. If you want A4 for TEST PRINT of TEST MENU, use Cold Reset A4; on the other hand, if you want LTR, use Cold Reset LTR.

If you have installed a different module or card, use Cold Reset.

•**Cold Reset LTR**

- (1) Make sure that the main unit is unplugged.
- (2) Press and hold down the **Item**, **Value** and **Enter/Cancel** buttons at the same time. Then plug the main unit in while still pressing the **Item**, **Value** and **Enter/Cancel** buttons.
- (3) When you see the “COLD RESET LTR” message, release all the buttons.

•**Cold Reset A4**

- (1) Make sure that the main unit is unplugged.
- (2) Press and hold down the **Menu**, **Item** and **Value** buttons at the same time. Then plug the main unit in while still pressing the **Menu**, **Item** and **Value** buttons.
- (3) When you see the “COLD RESET A4” message, release all the buttons.

•**Cold Reset**

- (1) Make sure that the main unit is unplugged.
- (2) Press and hold down the **Go** button. Then plug the main unit in while still pressing the **Go** button.
- (3) When you see the “COLD RESET” message, release all the buttons.

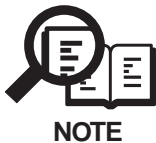

-
- After the factory defaults have been reset, the main unit enters the standby mode.
 - The main unit automatically checks which options are installed after a cold reset is performed. When the main unit has finished warming up, the On Line indicator comes on and “READY” appears in the display.
-

3.10.3 Technical informations

a) Configuration and construction

1. Product name FAX-L1000 Printer kit

2. External view

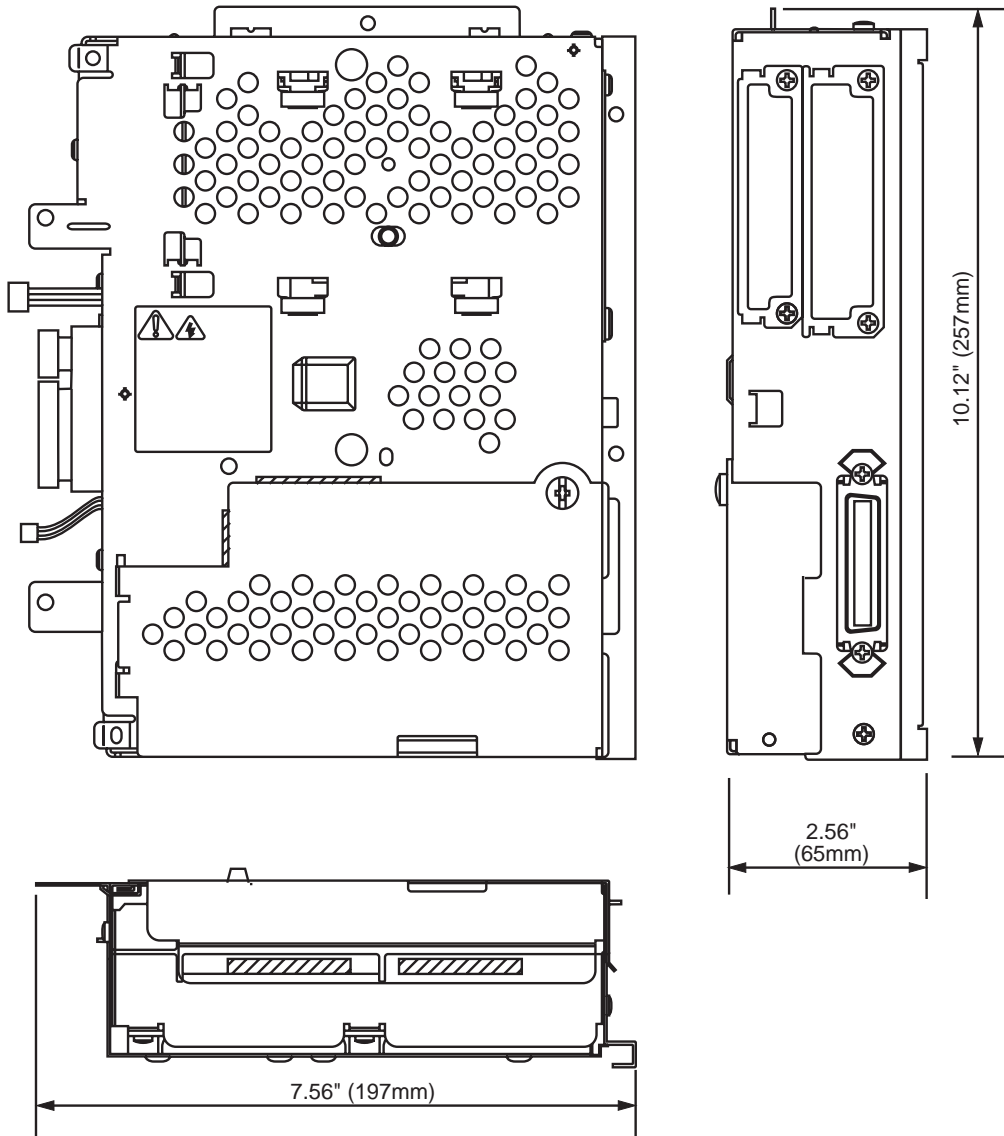

Figure 5-88 External View

b) Specifications

Printing resolution

600/1200 dpi

Printing speed (*1)

Approx. 17 pages/min. (Letter, 600 dpi), about 8.5 pages/min. (Letter, 1200 dpi)

Approx. 16 pages/min. (A4, 600 dpi), about 8 pages/min. (A4, 1200 dpi)

First print time (*2)

15.2 sec. or less (A4, 600 dpi, face-down)

14.1 sec. or less (A4, 600 dpi, face-up)

Wait time

25 sec. or less

Scanning pitch

Horizontal 600/1200 dpi

Vertical 600/1200 dpi

Image formation system

LASER	Semiconductor laser
Scanning system	Rotating six-faced prism mirror (Scanning mirror)
Photosensitive drum	OPC
Charging	Roller charging
Exposure	LASER scanning
Toner	Magnetic single-component dry toner
Development	Toner projection development
Toner supply	By FX6 cartridge replacement
Transfer	Roller transfer
Separation	Curvature
Cleaning	Blade
Fixing	On-demand method

Feeding

Multi-purpose tray, Cassette, Paper feeder, Envelope feeder (option)

Print paper

Plain paper, recycled paper, colored paper, labels, OHT, envelopes

Paper sizes

Multi-purpose tray	98.4mm (W) × 190mm (L)(min.) ~ 216mm (W) × 356mm (L) (max.) size plain paper (60g/m ² ~ 128g/m ² recommended paper), above-mentioned paper
Cassette1	Letter, Legal, and A4-sized plain paper (60g/m ² ~ 105g/m ² recommended paper), recycled paper, colored paper
Cassette2	Letter, Legal, B5-JIS, Executive, Custom and A4-sized plain paper (60g/m ² ~ 105g/m ² recommended paper), recycled paper, colored paper

Multi-purpose tray capacity

10mm stack (about 100 sheets of 80g/m² paper)

Cassette capacity

56mm stack (about 500 sheets of 80g/m² paper)

Cassette types

Cassette1	Universal (Letter, Legal, A4 sizes)
Cassette2	Universal (Letter, Legal, A4, B5-JIS, Executive, Custom sizes)

Print delivery

Face-down/Face-up

Face-down tray capacity

Upper output tray	17.4mm stack (Approx. 100 sheets of 80g/m ² paper)
Lower output tray	42.8mm stack (Approx. 200 sheets of 80g/m ² paper)

Face-up tray capacity

Approx. 50 sheets (80g/m² paper)

- *1. At the room temperature of 20°C with rated voltage input.
- *2. When the printer is in READY state at a room temperature of 20°C, the time from reception of the PRINT signal from the PDL board until an A4-sized print is delivered to the face-down or face-up tray.

CPU

RISC processor: Intel 960HD-50

RAM

Standard: 4MB
Maximum: 36MB

ROM

4MB

ROM DIMM socket

3

RAM DIMM socket

2

Host interface

Standard: IEEE 1284 parallel interface

Option: expansion interface (10BASE-T, 100BASE-TX)

Language

Standard: PCL 5e plus PCL-XL

Option: Adobe PostScript Level 3

Resident fonts

45 Scalable fonts (MicroType fonts), 8 Bitmap font

Optional fonts

136 fonts

Scalar

UFST

Dimensions

7.56" (W) × 10.12" (D) × 2.56" (H) (197mm × 257mm × 65mm)

Weight

Approx. 2.65 lbs (1.2 kg)



REFERENCE

Please refer to *Chapter 3: Technical Reference*, for printer function specifications.

c) Overview

•High speed printing

Equipped with the Intel 960HD-50 processor, this printer is compact in size and capable of printing a maximum of approx. 16 pages/min. (A4).

•Excellent image quality

Resolution of 1200/600/300DPI, super fine particle toner, and automatic image refinement provide excellent image.

•Various paper source in option

The three kinds of optional paper source, paper feeder, envelope feeder, and duplexing unit, will meet various requirements for a user.

In addition to the standard equipped multi-purpose tray and built-in cassette, installation of the optional paper feeder and envelope feeder provide a user the four-way paper pick-up sources.

Installation of the duplexing unit enables duplex printing.

•Memory saving technology

Memory Reduction Technology enables A4/LTR size single-side printing (1200 × 1200DPI resolution) with only 4MB of memory.

•Energy saving

Employment of on-demand fixing method that automatically reduces power consumption when the printer is idle for the specified period of time offers lower power consumption.

•Reduction in toner consumption

Toner consumption can be reduced by selecting the economy mode and printing rough image with lesser toner.

•Automatic PDL switch

This printer supports the Hewlett-Packard PCL6 printer language. It can also support the Adobe PostScript 3 by installing the optional FAX-L1000 PostScript Kit. It automatically switches PDL between PCL and PostScript according to the received data.

•Features of interface

This printer supports automatic interface switch between all active ports. The printer is equipped with the IEEE 1284 compliant parallel interface that supports bi-directional communication between the printer and the computer. The network board is available as an option, and the printer is equipped with the I/O slots that allow the printer to be connected to the Ethernet network environments. As a result, the printer can be connected to multiple computers simultaneously.

d) Operations

•Outline

When this unit is attached to the main unit, the main unit can be used as a PCL printer. This unit has a centronics interface, and can be used as a local printer by connection with a PC. Also, the following options are available with this board.

- FAX-L1000 Network Printer Upgrade Kit
- FAX-L1000 PostScript Kit
- RAM DIMM Module

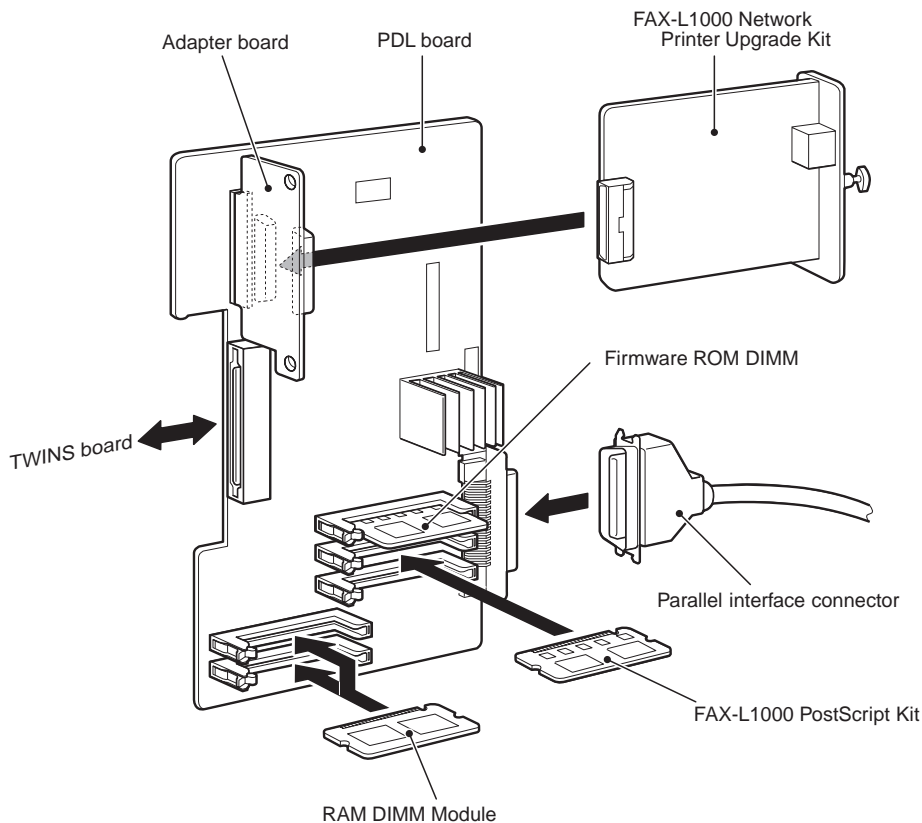

Figure 5-89 Options

Connecting this unit to the main unit gives it printer, fax, and copy functions.

With these functions, print operation is not done in priority sequence if performed simultaneously. Instead, the first function to request printing begins to print. However, one exception is when printing data received by fax and there is a request for printing from the printer, printing from the printer takes priority.

If a PDL unit is attached, the PRT. Message button on the lower right of the control panel LCD becomes available. When switching between fax and print operations, press the PRT. Message button. The printer button becomes unavailable when faxing, and the fax button becomes unavailable when printing.

•The Flow of Print Data

The main unit's printing operations are done totally independently when faxing and printing, but data communications between the PDL board and the ECNT board are all done through the SCNT board.

When printing, when PDL data is sent from the PC go the PDL board (when using the optional ethernet board), the PDL board converts the PDL data into print data and sends this converted data to the TWINS board.

When the PDL board and the TWINS board transmit print data, the flow of data is divided in to two categories, control (nCMD, nRDY, etc) and image (nVDO, nBD, nTOP), depending on the signal type.

a.Control Signal

- (1) The control signal is sent from the PDL board to the TWINS IC, passes through the data bus, and is forwarded to the system controller IC on the SCNT board.
- (2) The control signal sent to the system controller IC is sent to the ECNT board as-is.
- (3) The ECNT board sends a signal to the SCNT board system controller IC in response to the control signal it received.
- (4) The response signal is forwarded from the system controller IC to the TWINS IC, passing through the data bus, and is sent to the PDL board.

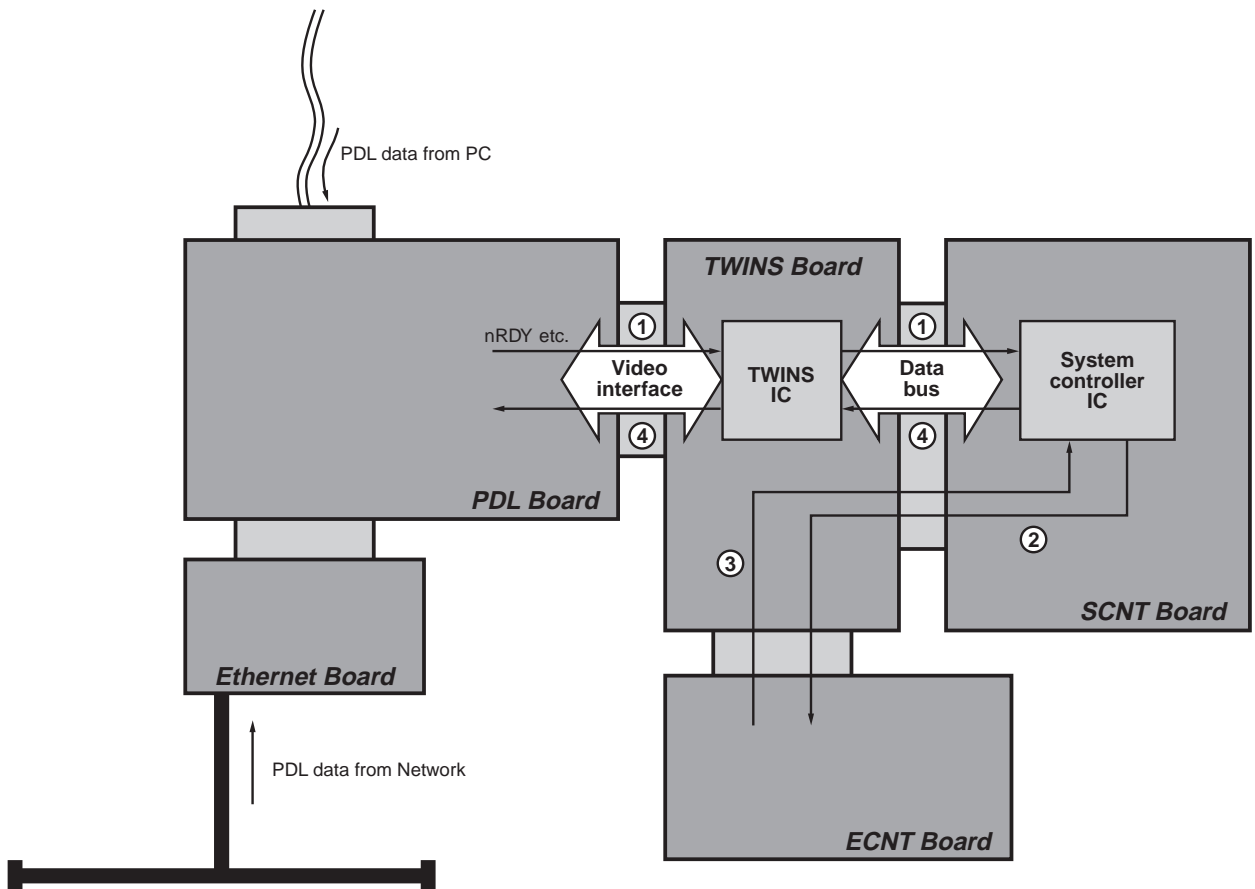

Figure 5-90 Flow of Print Data 1

b. Image Signal

- (1) The image signal (nVDO) is sent from the PDL board to the TWINS board selector IC.
- (2) The image signal (nVDO) from the fax (SCNT board) and the image signal (nVDO) from the printer (PDL board) are switched by the selector IC.
- (3) The nBD and nTOP signals from the ECNT board are separated by the TWINS board and sent to the SCNT board and the PDL board. However, with facsimile printing, the signal which would be sent to the PDL board is switched by the selector ICD on the TWINS board so that it is not sent to the PDL board. With printer printing, it is switched so that it will be sent.

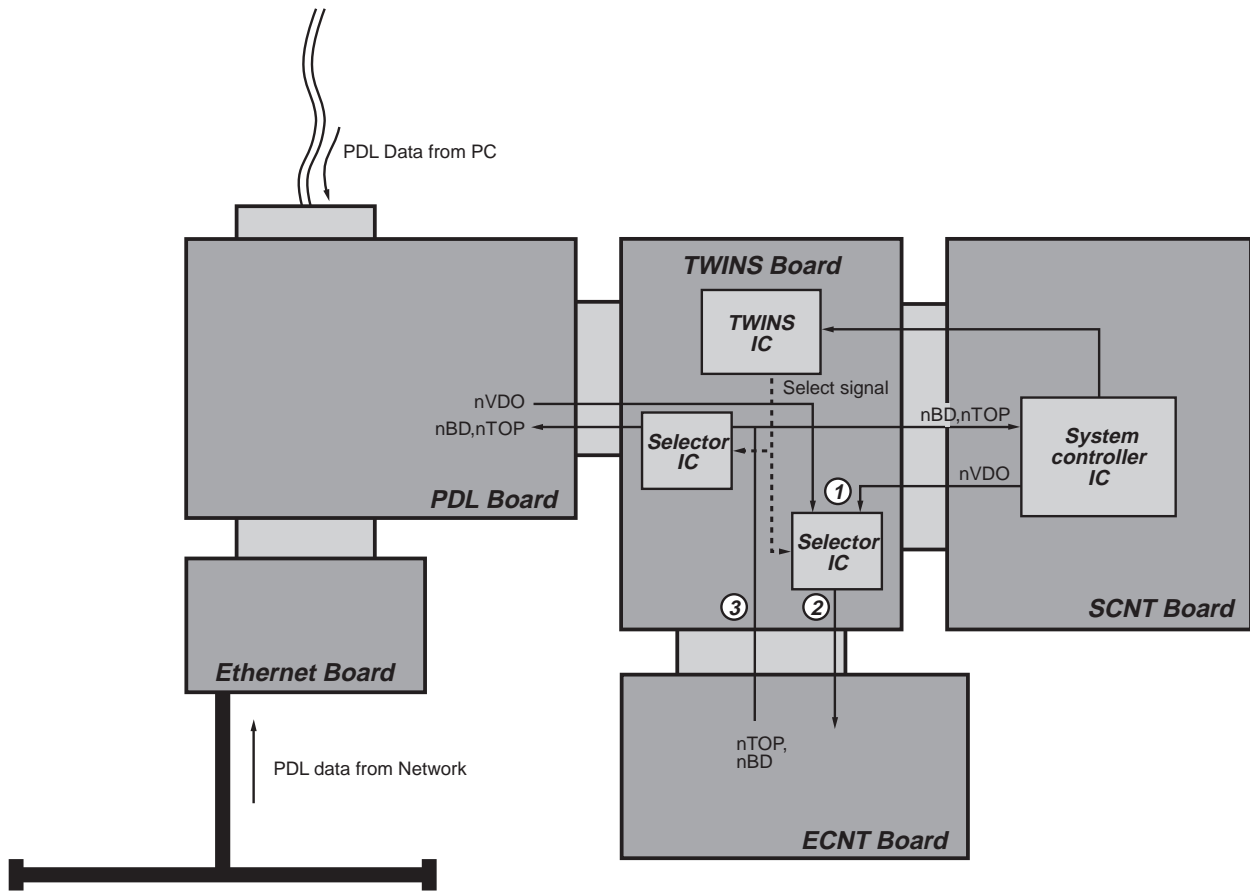

Figure 5-91 Flow of Print Data 2

•Control Panel

The PDL board also controls the printer operation buttons. All communication between the buttons and the PDL board is done via the SCNT board.

•Menus Operation Flow

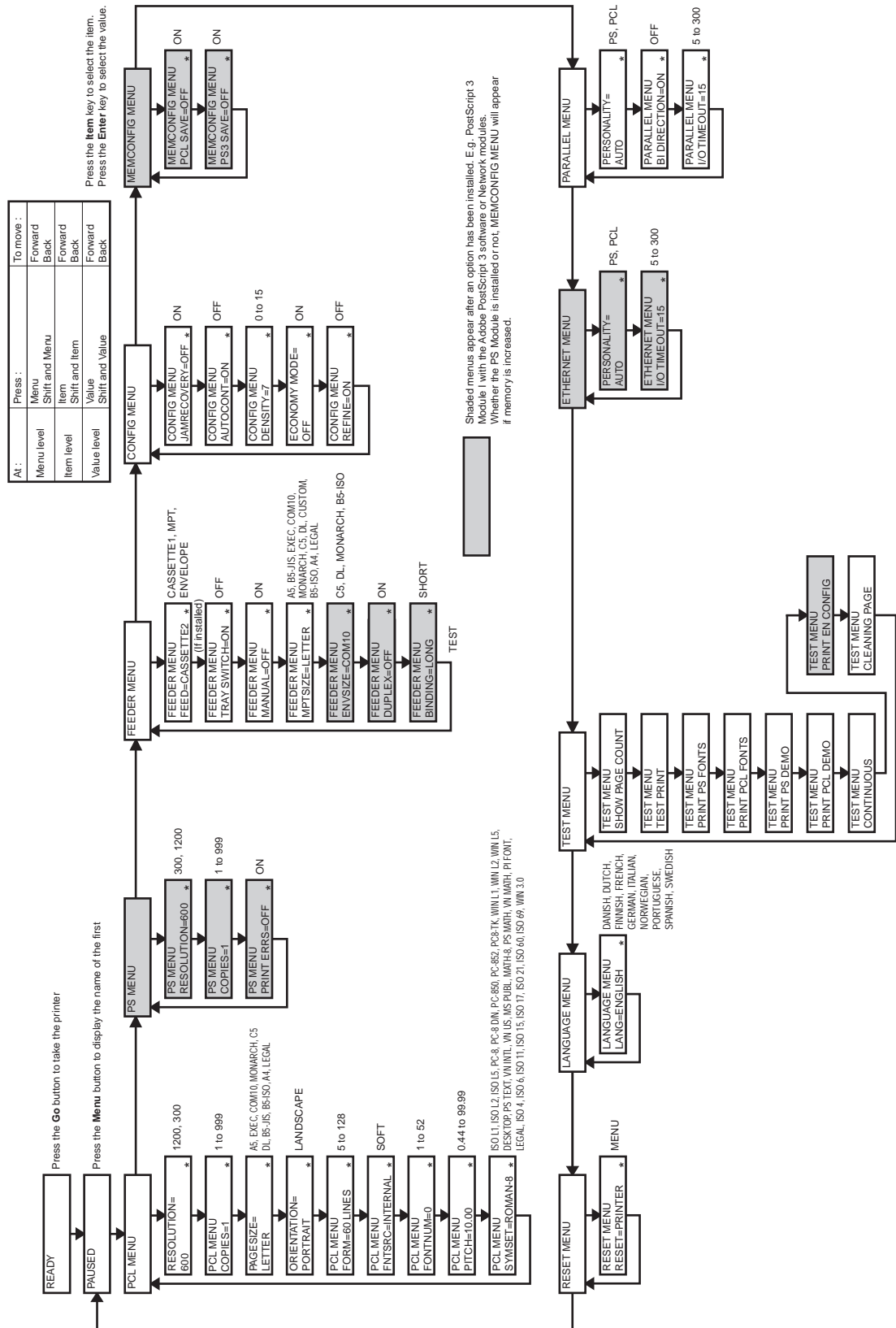

Figure 5-92 PDL Menu Flow

e) Components

Video controller circuit receives print data consisting of code or image data from external device (such as host computer) via interface cable.

The circuit analyzes and processes the print data including the data specified by the operation panel, and then converts them to the dot data. The dot data are sent to the ECNT board to control the laser diode emission.

The layout of the main ICs on this circuit is in Figure 5-93, and the block diagram in Figure 5-94.

CPU (IC1)

A 32-bit RISC microprocessor (FC80960HD) made by Intel co. is used for the CPU in the printer, and its operation frequency is 50MHz. The CPU controls the operation of the PDL board according to the control program stored in the ROM.

ASIC (IC2)

The ASIC is graphic co-processor and has the following functions.

- DRAM control
- ROM control
- Video interface control
- IEEE 1284 parallel port interface control
- I/O bass interface support

ASIC (AIR, IC3)

The ASCII has smoothing control circuit and SRAM.

Its main functions are as follows.

- Smoothing control of image
- EEPROM control
- Operation panel interface control

DRAM

4-Mbyte DRAM is installed on the PDL board.

72pin-DIMM of 4-, 8-, or 16-Mbyte can be installed to the two slots on the PDL board.

ROM

A 4 Mbyte ROM is installed on the PDL board. In some cases, the 4 Mbyte ROM is installed on the firmware ROM DIMM. In those cases, this ROM DIMM is installed in the connector (J6) on the PDL board.

Of the three connectors, the two connectors, one in the middle (J7) and the other one at the bottom (J8), can be used by the user to install 4 Mbyte or 8 Mbyte ROM DIMM. The optional FAX-L1000 PostScript Kit is installed in the middle connector (J7). The bottom connector (J8) is not used. The connector at the top (J6) is exclusively for the Firmware ROM DIMM.

EEPROM (IC10)

EEPROM is 4-Kbytes, and is used for storing the factory default value and the user set value defined on the operation panel.

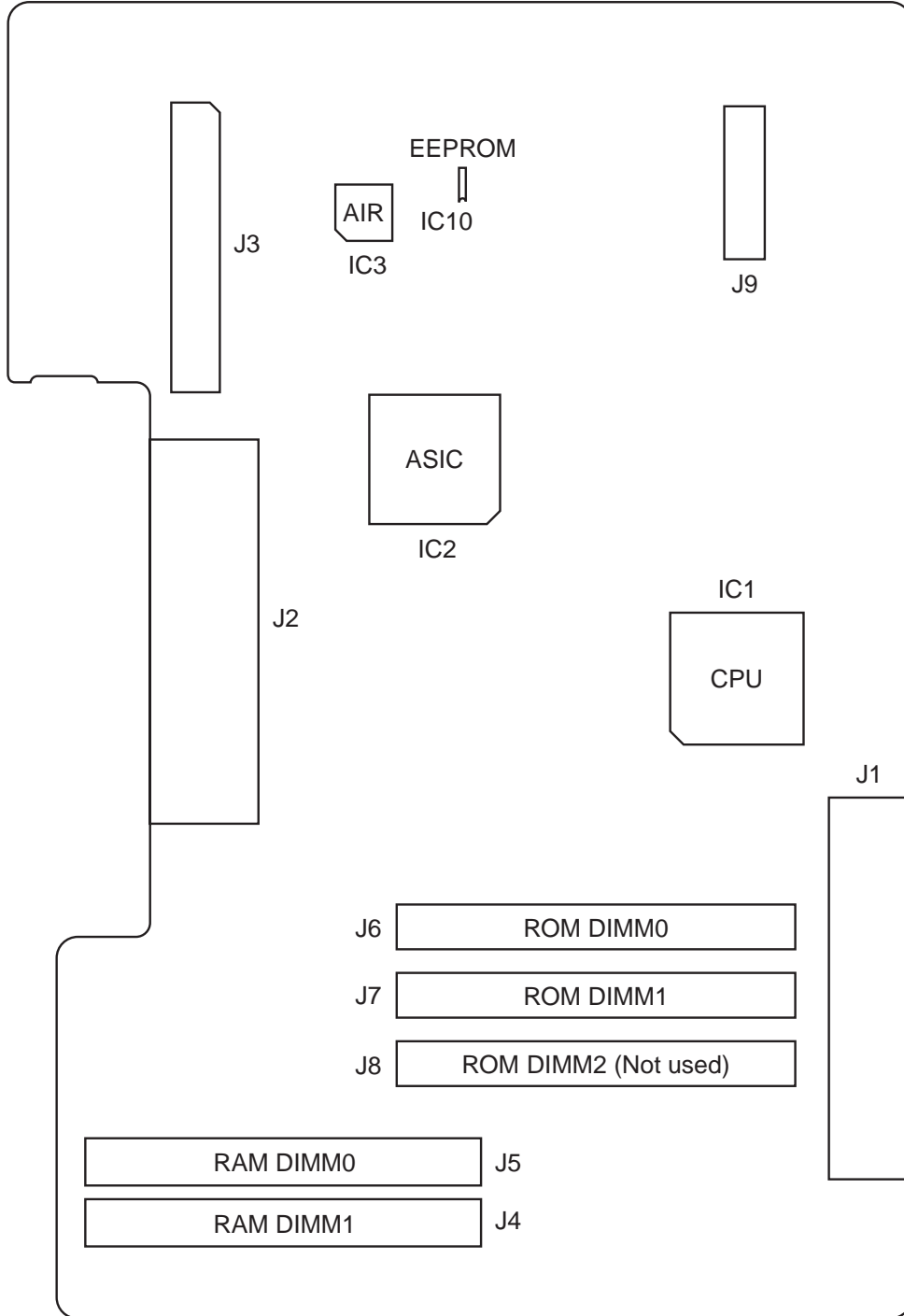

Figure 5-93 Components

3.10.4 Maintenance and service

a) Test print

The following items can be printed by selecting and executing a **TEST MENU**:

•SHOW PAGE COUNT

Displays the total number of printed pages when used as a printer. The total page number is only shown briefly on the display but does not print. The page count prints in the TEST PRINT.



This counter displays the number of printed pages when used as a printer. When checking the total number of printed pages for this unit, please check with the service mode #7 PRINTER #3 PRINT COUNT.

•TEST PRINT

Make a Test Print. The Test Print lists the printing environment settings and also displays the graphic and text printing capabilities.

•PRINT PS FONTS

Available only after the Translator Module A5 for FAX-L1000 PostScript Kit has been installed. Prints the PS Font List.

•PRINT PCL FONTS

Prints the PCL Font List.

•PRINT PS DEMO

Available only after the Translator Module A5 for FAX-L1000 PostScript Kit has been installed. Prints the PS demonstration page.

•PRINT PCL DEMO

Prints the PCL demonstration page.

•CONTINUOUS TEST

Make continuous Test Prints.

•CLEANING PAGE

See following page.

Follow these steps to make a Test Print:

- (1) Press the **Go** button to set the printer off-line. The On line indicator should be **OFF** and **PAUSED** appears in display.
- (2) Press the **Menu** button until you see “TEST MENU” in the top line.
- (3) Press the **Item** button until you see “TEST PRINT” in the bottom line.
- (4) Press the **Enter** button to start printing a Test Print.
- (5) After the pages are printed, press the **Go** button to put the printer on-line.

Use the Test Print to verify the operation panel selections, system configurations (memory and options), and print quality.

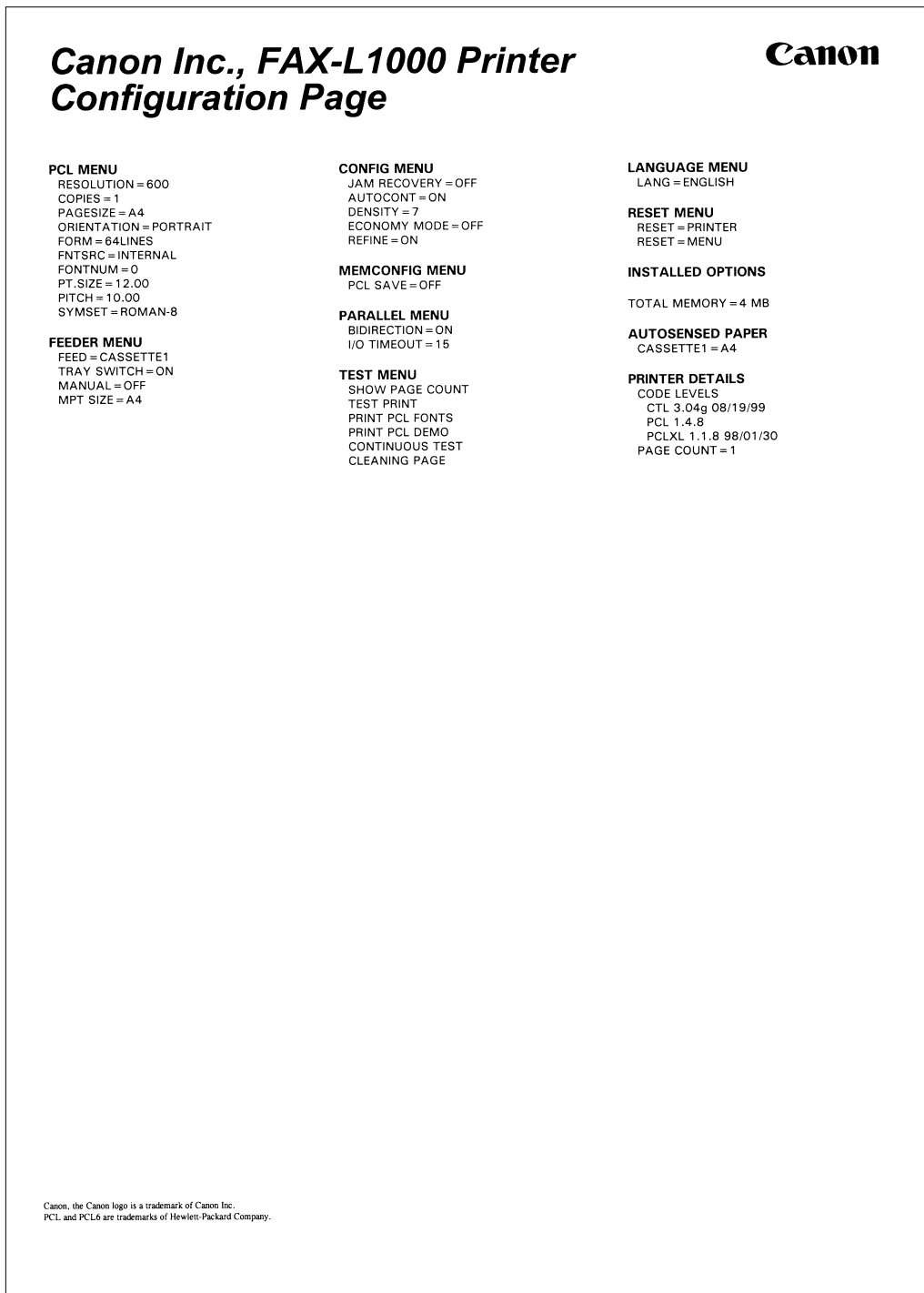

Figure 5-95 Test Print

•Cleaning Page

When the dirty fixing unit is the cause of image defect, the fixing unit can be cleaned by the user.

The toner on the upper pressure roller can be removed by printing the cleaning pattern in figure 5-96 Cleaning Page and re-feeding the paper (cleaning page). The procedure is as shown below.

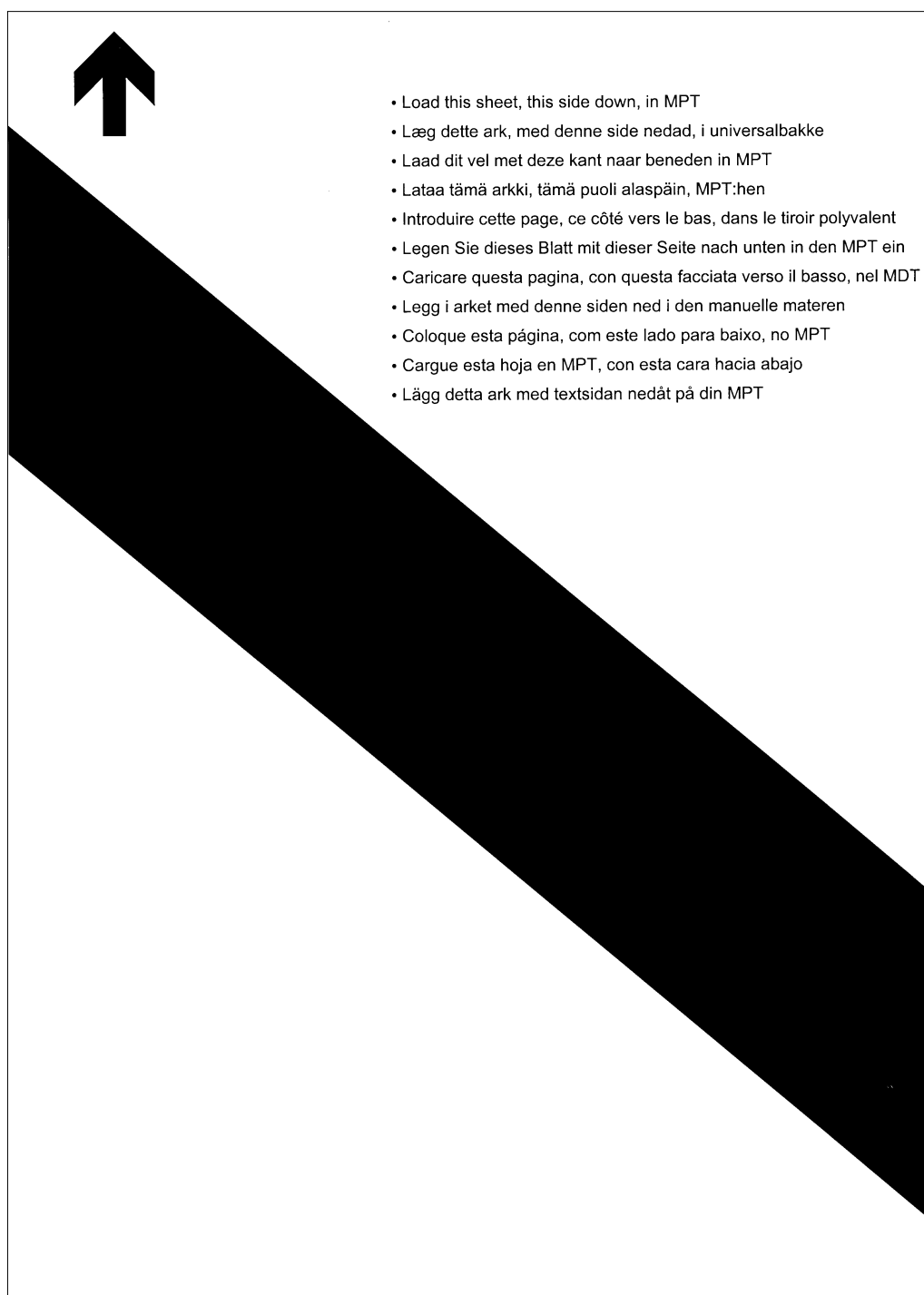

Figure 5-96 Cleaning Page

- (1) Press the **Go** button to set the printer off-line. The On line indicator should be **OFF** and **PAUSED** appears in display.
- (2) Press the **Menu** button until you see “TEST MENU” in the top line.
- (3) Go to the “CLEANING PAGE” item in the TEST MENU.
- (4) Press the **Enter/Cancel** button.
- (5) The message “LOAD <size> IN MANUAL” is displayed (Because the data requests Manual feed mode.) [Note]
- (6) Load a paper requested in the multi-purpose tray.
- (7) Press the **Go** button.
- (8) CLEANING PAGE is created at 600dpi.
- (9) The message “LOAD CLEANING PAGE IN MANUAL” is displayed after delivering paper.
- (10) Load the sheet (CLEANING PAGE), the printed side down, in the multi-purpose tray.
- (11) Press the **Go** button.
- (12) Print blank page onto cleaning page at 1200dpi.



The paper size requested by ‘cleaning page’ is page size item value in PCL MENU.

b) Troubleshooting

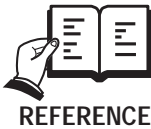

Please refer to *Chapter 4: Maintenance and Service* for information related to printing problems, trouble with facsimile functions, etc.

REFERENCE

"5F-50 ERROR" (fixing unit malfunction)

<Possible causes>

1. Broken or short-circuited thermistor

Action: Turn the power OFF and remove the fixing unit. Measure the resistance between the fixing unit connector J132-1 (THRM) and J132-2 (GND). If the resistance is not in the range of 300kΩ to 500kΩ (standard temperature), replace the fixing film unit.

2. Broken heater wire/blown thermal fuses

Action: If there is no continuity between the fixing unit connectors J143F (NEUTRAL) and J142F (HOT) with the fixing unit removed, replace the fixing film unit.

3. Defective ECNT board

Action: Replace the ECNT board.

"5F-52 ERROR" (Scanner unit malfunction)

<Possible causes>

1.Poor contact in LASER/scanner unit connectors

Action: Reconnect the BD board connector J551, LASER driver board connector J501 and scanner motor connector J401.

2.Poor contact in ECNT board connector

Action: Reconnect the ECNT board connector J53 correctly.

3.Defective LASER/scanner unit

Action: Replace the LASER/scanner unit.

4.Defective ECNT board

Action: Replace ECNT board.

5.Defective SCNT board

Action: Replace SCNT board.

6.Defective TWINS board

Action: Replace the TWINS board.

7.Defective PDL board

Action: Replace the PDL board.

"5F-54 ERROR" (Main motor malfunction)

<Possible causes>

1.Poor contact in the MAIN MOTOR DRIVE signal line connectors

Action: Reconnect the main motor connector J301 and ECNT board connector J52 correctly.

2.Defective main motor

Action: Replace the main motor.

3.Defective ECNT board

Action: Replace ECNT board.

4.Defective SCNT board

Action: Replace SCNT board.

5.Defective TWINS board

Action: Replace TWINS board.

6.Defective PDL board

Action: Replace the PDL board.

"5F-56 ERROR" (Duplexing unit exhaust fan (FM701) malfunction)

<Possible causes>

1. Poor contact in the connectors of the FM701 drive signal line

Action: Reconnect the intermediate connectors J718 and J719, then the duplexing unit driver board connector J707.

2. Defective fan motor

Action: Replace the exhaust fan.

3. Defective duplexing unit driver board

Action: Replace the duplexing unit driver board.

"5F-59 ERROR" (Cooling fan (FM101) malfunction)

<Possible causes>

1. Poor contact in the connector of the FM101 drive signal line

Action: Reconnect the ECNT board connector J54.

2. Defective fan motor

Action: Disconnect the ECNT board connector J54. Turn the power ON, then measure the voltage between ECNT board connector J54-1 (/FON) and J54-3 (GND). If the voltage changes from 0V to about 24V, replace the cooling fan.

3. Defective ECNT board

Action: Replace the ECNT board.

4. Defective SCNT board

Action: Replace the SCNT board.

5. Defective TWINS board

Action: Replace the TWINS board.

6. Defective PDL board

Action: Replace the PDL board.

"5F-60 ERROR" (Duplex Option error)

<Possible causes>

1. Defective duplexing unit connector

Action: Remove the duplexing unit from the printer and check the connector. Replace the connector if any failure is found.

2. Defective printer connector

Action: Check the connector. Replace the connector if any failure is found.

3. Defective duplexing unit driver board

Action: Replace the duplexing unit driver board.

4. Defective ECNT board

Action: Replace the ECNT board

5. Defective SCNT board

Action: Replace the SCNT board.

6. Defective TWINS board

Action: Replace the TWINS board.

7. Defective PDL board

Action: Replace the PDL board.

"5F-61 ERROR" (Envelope Option error)

<Possible causes>

1. Defective envelope feeder connector

Action: Remove the envelope feeder from the printer and check the connector. Replace the connector if any failure is found.

2. Defective printer connector

Action: Check the connector. Replace the connector if any failure is found.

3. Defective envelope feeder driver board

Action: Replace the envelope feeder driver board.

4. Defective ECNT board

Action: Replace the ECNT board.

5. Defective SCNT board

Action: Replace the SCNT board.

6. Defective TWINS board

Action: Replace the TWINS board.

7. Defective PDL board

Action: Replace the PDL board.

"5F-62 ERROR" (Feeder Option error)

<Possible causes>

1. Defective paper feeder connector

Action: Remove the paper feeder and check the connector. If any failure is found, replace it.

2. Defective printer connector

Action: Check the connector. If any failure is found, replace it.

3. Defective paper feeder driver board

Action: Replace the paper feeder driver board.

4. Defective ECNT board

Action: Replace the ECNT board.

5. Defective SCNT board

Action: Replace the SCNT board.

6. Defective TWINS board

Action: Replace the TWINS board.

7. Defective PDL board

Action: Replace the PDL board.

"6F-61 ERROR" (Resident ROM checksum error)

<Possible causes>

1. Defective firmware ROM DIMM

Action: Replace the firmware ROM DIMM.

2. Defective PDL board

Action: Replace the PDL board.

"6F-63 ERROR" (Resident DRAM checksum error)

<Possible causes>

1. Defective PDL board

Action: Replace the PDL board.

"6F-68 ERROR" (NVRAM (EEPROM) error)

<Possible causes>

1. Defective PDL board

Action: Replace the PDL board.

"6F-7A ERROR" (SRAM in AIR chip error)

<Possible causes>

1. Defective PDL board

Action: Replace the PDL board.

"PARALLEL INTERFACE ERROR"

<Possible causes>

1. Defective PDL board

Action: Replace the PDL board.

"TONER CARTRIDGE MISSING" message appears when it is installed

<Possible causes>

1.Poor contact between the printer contact and the cartridge contact

Action: Clean the contacts if dirty. Replace the part(s) if deformed or damaged, or the problem still remains after cleaning.

2.Defective cartridge

Action: Replace the cartridge.

3.Defective ECNT board

Action: Replace the ECNT board.

4.Defective SCNT board

Action: Replace the SCNT board.

5.Defective TWINS board

Action: Replace the TWINS board.

6.Defective PDL board

Action: Replace the PDL board.

"CASSETTE 1 MISSING" message appears when it is installed

<Possible causes>

1.Damaged cassette size lever in the cassette

Action: Replace the lever.

2.Defective paper size detection board

Action: Replace the paper size detection board.

3.Defective ECNT board

Action: Replace the ECNT board.

4.Defective SCNT board

Action: Replace the SCNT board.

5.Defective TWINS board

Action: Replace the TWINS board.

6.Defective PDL board

Action: Replace the PDL board.

"PRINTER OPEN" message appears when the cover is closed

<Possible causes>

1.Damaged cartridge door lever

Action: Replace the cartridge door.

2. Defective printer cover

Action: Replace the printer cover sensor.

3. Defective ECNT board

Action: Replace the ECNT board.

4. Defective SCNT board

Action: Replace the SCNT board.

5. Defective TWINS board

Action: Replace the TWINS board.

6. Defective PDL board

Action: Replace the PDL board.

"TOP BIN FULL" message appears when the actual paper level is not full

<Possible causes>

1. Locked or damaged recording paper overload sensor lever

Action: Set the lever to move smoothly. Replace it if damaged.

2. Defective recording paper overload sensor.

Action: Replace the sensor.

3. Defective ECNT board

Action: Replace the ECNT board.

4. Defective SCNT board

Action: Replace the SCNT board.

5. Defective TWINS board

Action: Replace the TWINS board.

6. Defective PDL board

Action: Replace the PDL board.

"LOAD <SIZE> IN CASSETTE 1" message appears when the specified sized paper is in the cassette

<Possible causes>

1. Damaged paper detection lever

Action: Replace the lever.

2. Defective recording paper size sensor

Action: Replace the sensor.

3. Defective paper size detection board

Action: Replace the paper size detection board.

4. Defective ECNT board

Action: Replace the ECNT board.

5. Defective SCNT board

Action: Replace the SCNT board.

6. Defective TWINS board

Action: Replace the TWINS board.

7. Defective PDL board

Action: Replace the PDL board.

"LOAD <SIZE> IN MPT" message appears when the specified sized paper is in the multi-purpose tray

<Possible causes>

1. Damaged paper detection lever

Action: Replace the lever.

2. Defective multi-purpose tray paper sensor

Action: Replace the sensor.

3. Defective ECNT board

Action: Replace the ECNT board.

4. Defective SCNT board

Action: Replace the SCNT board.

5. Defective TWINS board

Action: Replace the TWINS board.

6. Defective PDL board

Action: Replace the PDL board.

"LOAD <SIZE> IN CASSETTE 2" message appears when the specified sized paper is in the paper feeder

<Possible causes>

1. Damaged paper detection lever

Action: Replace the lever.

2. Defective cassette recording paper size sensor of the Paper Feed Unit PF-52

Action: Replace the sensor.

3. Defective paper feeder driver board

Action: Replace the paper feeder driver board.

4. Defective paper size detection board

Action: Replace the paper size detection board.

5. Defective ECNT board.

Action: Replace the ECNT board.

6. Defective SCNT board

Action: Replace the SCNT board.

7. Defective TWINS board

Action: Replace the TWINS board.

8. Defective PDL board

Action: Replace the PDL board.

"LOAD <SIZE> IN ENV." message appears when the specified sized envelope is in the envelope feeder.

<Possible causes>

1. Damaged envelope detection lever

Action: Replace the lever.

2. Defective envelope feeder driver board

Action: Replace the envelope feeder driver board.

3. Defective ECNT board

Action: Replace the ECNT board.

4. Defective SCNT board

Action: Replace the SCNT board.

5. Defective TWINS board

Action: Replace the TWINS board.

6. Defective PDL board

Action: Replace the PDL board.

"CLOSE FACE-UP TRAY" message appears when the face-up tray is closed at the time of using duplexing unit

<Possible causes>

1. Spring is out of position

Action: Remove the right cover of the duplexing unit and check the spring. If the spring is out of position, set it in the correct position.

2.Damaged top cover sensor lever of the duplexing unit

Action: Replace the top cover.

3.Defective face-up tray paper sensor

Action: Replace the sensor.

4.Defective duplexing unit driver board

Action: Replace the duplexing unit driver board.

"PAPER JAM" message appears when the paper jam has not occurred, and the printer cannot be in READY mode.

<Possible causes>

1.Top of page sensor lever does not move smoothly or is damaged.

Action: Set the lever to move smoothly. Replace it if damaged.

2.Recording paper eject sensor lever does not move smoothly or is damaged.

Action: Set the lever to move smoothly. Replace it if damaged.

3.Defective top of page sensor

Action: Replace the sensor.

4.Defective recording paper eject sensor 1

Action: Replace the sensor.

5.Defective ECNT board

Action: Replace the ECNT board.

6.Defective SCNT board

Action: Replace the SCNT board.

7.Defective TWINS board

Action: Replace the TWINS board.

8.Defective PDL board

Action: Replace the PDL board.

"DUPLEX JAM" message appears when the paper jam has not occurred; so, the printer cannot be in READY mode.

<Possible causes>

1.Reversing paper sensor lever does not move smoothly, or is damaged.

Action: Set the lever to move smoothly. Replace it if damaged.

2.Duplexing unit pick-up paper sensor lever does not move smoothly, or is damaged.

Action: Set the lever to move smoothly. Replace it if damaged.

3. Defective reversing paper sensor

Action: Replace the sensor.

4. Defective duplexing unit pick-up paper sensor 1

Action: Replace the sensor.

5. Defective duplexing unit driver board

Action: Replace the duplexing unit driver board.

6. Defective ECNT board

Action: Replace the ECNT board.

7. Defective SCNT board

Action: Replace the SCNT board.

8. Defective TWINS board

Action: Replace the TWINS board.

9. Defective PDL board

Action: Replace the PDL board.

c) Signal description

PDL board(J2) ↔ TWINS board connector(J35)

J2		J35	Signal name	Description
a1	←	1	+3.3V	Logic drive voltage
a2	—	2	GND	Ground

PDL board(J2) ↔ TWINS board connector(J34)

J2		J34	Signal name	Description
b1	→	10	+5.0V	PDL board detect signal H:Yes, L:No
b2	→	9	nSCEN	Serial clock enable
b3	→	8	nPCLK	Clock
b4	→	7	nCOMWR	The SO signal is a signal for distinguishing between commands and data. H:Command L:Data
b5	—	6	nDENB	Not used
b6	→	5	SO	Operation panel control signal (Command or Data)
b7	←	4	SI	Button data
b8	—	3	GND	Ground
b9	←	2	+3.3V	Logic drive voltage
b10	—	1	GND	Ground

PDL board(J2) ↔ TWINS board connector(J33)

J2		J33	Signal name	Description
c1	—	26	GND	Ground
c2	←	25	nBD	Horizontal sync signal
c3	←	24	nPPRDY	Printer power ready signal
c4	←	23	nRDY	Ready signal
c5	←	22	nTOP	Vertical sync signal
c6	←	21	nSBSY	Status busy signal
c7	←	20	nSTS	Status signal

PDL board(J2) ↔ TWINS board connector(J33)

J2		J33	Signal name	Description
c8	—	19	nPCLK	Not used
c9	→	18	nCBSY	Command busy signal
c10	→	17	nPRNT	Print signal
c11	→	16	nPRFD	Pre-feed signal
c12	→	15	nCPRDY	Controller power ready signal
c13	—	14	GND	Ground
c14	→	13	nCMD	Command signal
c15	→	12	nCCLK	Controller clock signal
c16	—	11	GND	Ground
c17	→	10	nVDO	Video signal
c18	—	9	GND	Ground
c19	←	8	nCCRT	Condition change report signal
c20	—	7	nPDLV	Not used
c21	—	6	nPFED	Not used
c22	—	5	NC	Not connected
c23	←	4	+5.0V	Logic drive voltage
c24	←	3	+5.0V	Logic drive voltage
c25	—	2	GND	Ground
c26	—	1	GND	Ground

This page intentionally left blank



Printed on paper that
contains 60% reused paper.

Canon